

### Features

- Batch process design, excellent power dissipation offers better reverse leakage current and thermal resistance.
- Low profile surface mounted application in order to optimize board space.
- Low power loss, high efficiency.
- High surge capability.
- Guardring for overvoltage protection.
- Ultra high-speed switching.
- Silicon epitaxial planar chip, metal silicon junction.
- Lead\_free parts meet environmental standards of MIL-STD-19500 /228
- Compliant to Halogen-free
- Suffix "-Q1" for AEC-Q101

### Mechanical data

- Epoxy:UL94-V0 rated flame retardant
- Case : TO-277B , molded Plastic
- Terminals:Solderable per MIL-STD-750,Method 2026
- Marking:Pages 3

### Package outline

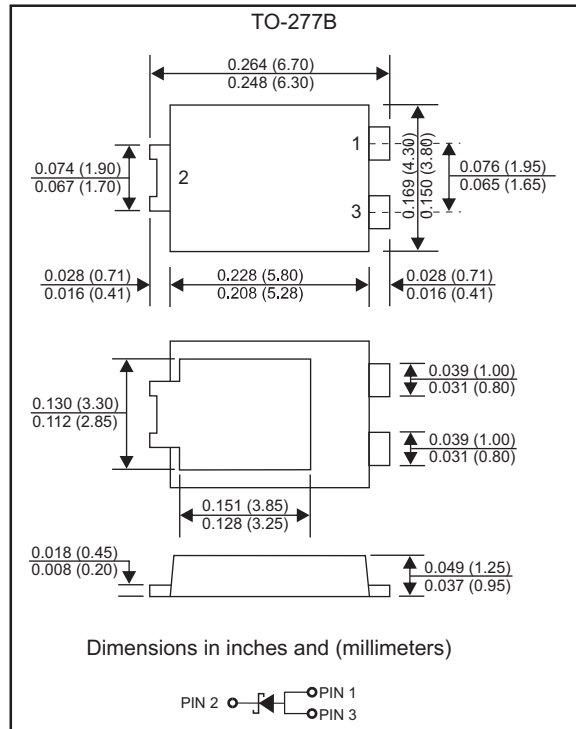

### Maximum ratings and Electrical Characteristics (AT $T_A=25^{\circ}\text{C}$ unless otherwise noted)

PARAMETER	CONDITIONS	Symbol	MIN.	TYP.	MAX.	UNIT
Forward rectified current	See Fig.1	$I_o$			8.0	A
Forward surge current	8*3ms single half sine-wave (JEDEC methode)	$I_{FSM}$			150	A
Reverse current	$V_R = V_{RRM} T_J = 25^{\circ}\text{C}$	$I_R$			0.05	mA
	$V_R = V_{RRM} T_J = 100^{\circ}\text{C}$				10	
Typical Thermal resistance	Junction to ambient	$R_{\theta JA}$		60		$^{\circ}\text{C}/\text{W}$
Storage temperature		$T_{STG}$	-55		+150	$^{\circ}\text{C}$

SYMBOLS	$V_{RRM}^{*1}$ (V)	$V_{RMS}^{*2}$ (V)	$V_R^{*3}$ (V)	$V_F^{*4}$ (V)	Operating temperature $T_J, (^{\circ}\text{C})$
SS8100-T-Q1	100	70	100	0.85	-55 to +150

\*1 Repetitive peak reverse voltage

\*2 RMS voltage

\*3 Continuous reverse voltage

\*4 Maximum forward voltage@ $I_F=8.0\text{A}$

## Rating and characteristic curves

FIG. 1- DERATING CURVE OUTPUT RECTIFIED CURRENT

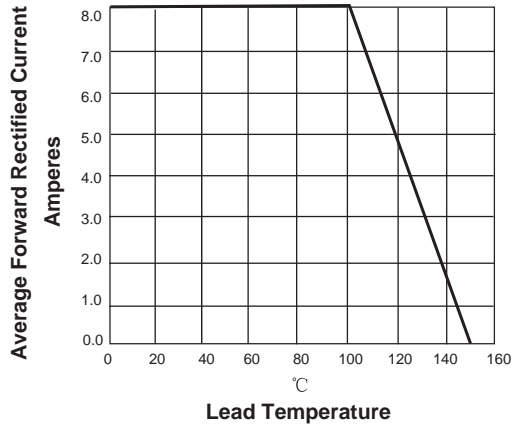

FIG. 2-MAXIMUM NON-REPETITIVE PEAK FORWARD SURGE CURRENT PER LEG

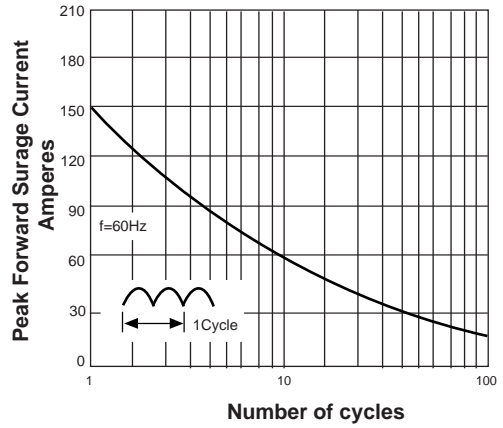

FIG. 3-TYPICAL FORWARD VOLTAGE CHARACTERISTICS

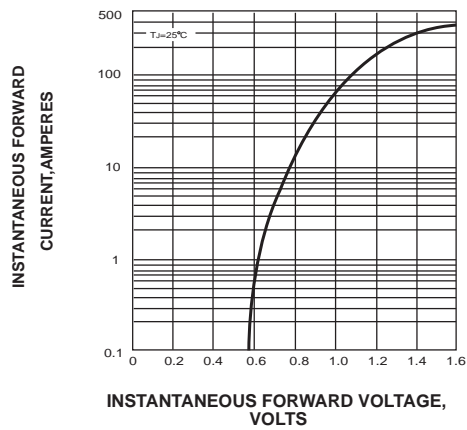
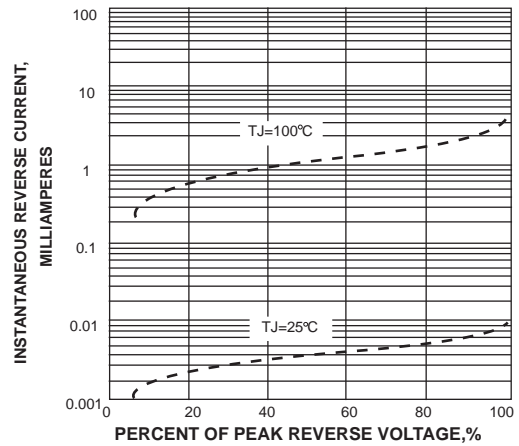

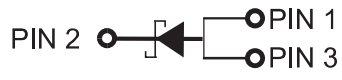

FIG. 4-TYPICAL REVERSE LEAKAGE CHARACTERISTICS



### Pinning information

Pin	Simplified outline	Symbol
PIN 1 anode PIN 3 anode PIN 2 cathode		

### Marking

Type number	Marking code
SS8100-T-Q1	SS8100

### Suggested solder pad layout

TO-277B

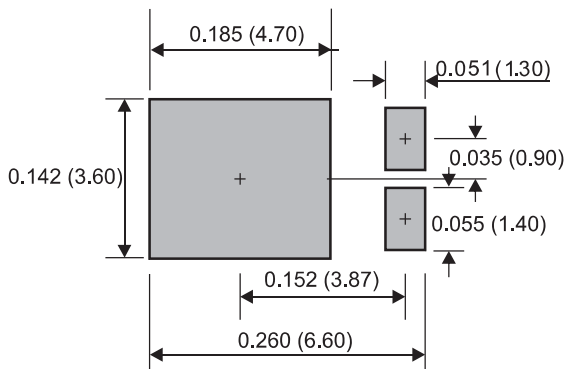

Dimensions in inches and (millimeters)