

Features

- ▶ The plastic package carries Underwriters Laboratory Flammability Classification 94V-0
- ▶ For surface mounted applications
- ▶ Metal silicon junction, majority carrier conduction
- ▶ Low power loss, high efficiency
- ▶ Built-in strain relief, ideal for automated placement
- ▶ High forward surge current capability
- ▶ High temperature soldering guaranteed: 250°C/10 seconds at terminals
- ▶ Compliant to RoHS Directive 2011/65/EU
- ▶ Compliant to Halogen-free

Mechanical data

- ▶ **Case:** JEDEC DO-214AC molded plastic body
- ▶ **Terminals:** Solder plated, solderable per MIL-STD-750, Method 2026
- ▶ **Polarity:** Color band denotes cathode end
- ▶ **Mounting Position:** Any

Package outline

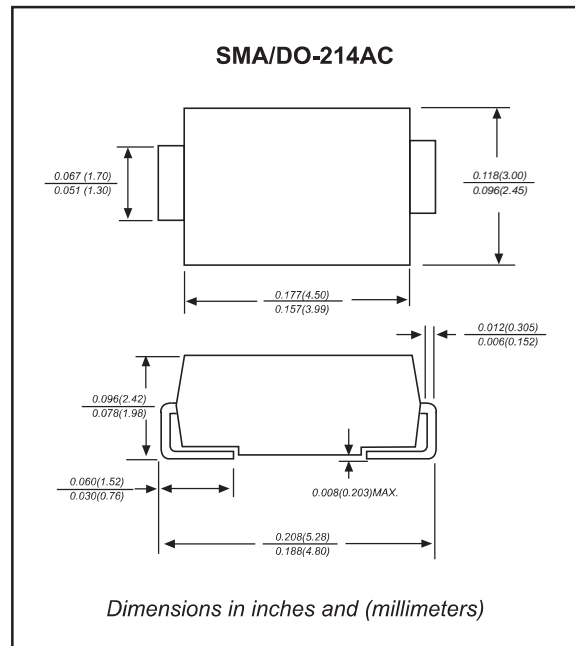

Maximum ratings and Electrical Characteristics (AT $T_A=25^\circ\text{C}$ unless otherwise noted)

PARAMETER	CONDITIONS	Symbol	MIN.	TYP.	MAX.	UNIT
Forward rectified current	See Fig.1	I_O			5.0	A
Forward surge current	8.3ms single half sine-wave (JEDEC methode)	I_{FSM}			120	A
Reverse current	$T_A = 25^\circ\text{C}$	$V_R = 20\text{V} - 60\text{V}$			0.5	mA
		$V_R = 80\text{V} - 200\text{V}$			0.1	
Reverse current	$T_A = 100^\circ\text{C}$	$V_R = 20\text{V} - 60\text{V}$			10	mA
		$V_R = 80\text{V} - 200\text{V}$			5	
Thermal resistance (1)	Junction to Ambient	$R_{\theta JA}$		70		$^\circ\text{C}/\text{W}$
	Junction to Case	$R_{\theta JC}$		25		
	Junction to Lead	$R_{\theta JL}$		30		
Diode junction capacitance	f=1MHz and applied 4V DC reverse voltage	C_J		200		pF
Storage temperature		T_{STG}	-65		+150	$^\circ\text{C}$

Note: (1) Device mounted on p.c.b. with 10 mm x 20 mm x 0.1 mm copper pad area.

SYMBOLS	V_{RRM}^{*1} (V)	V_{RMS}^{*2} (V)	V_R^{*3} (V)	V_F^{*4} (V)	Operating temperature T_J , ($^\circ\text{C}$)
SS52-A	20	14	20	0.55	
SS53-A	30	21	30		
SS54-A	40	28	40		
SS55-A	50	35	50	0.70	
SS56-A	60	42	60		
SS58-A	80	56	80	0.85	
SS510-A	100	70	100		
SS515-A	150	105	150	0.92	
SS520-A	200	140	200		

*1 Repetitive peak reverse voltage

*2 RMS voltage



*3 Continuous reverse voltage

*4 Maximum forward voltage@ $I_F=5.0\text{A}$

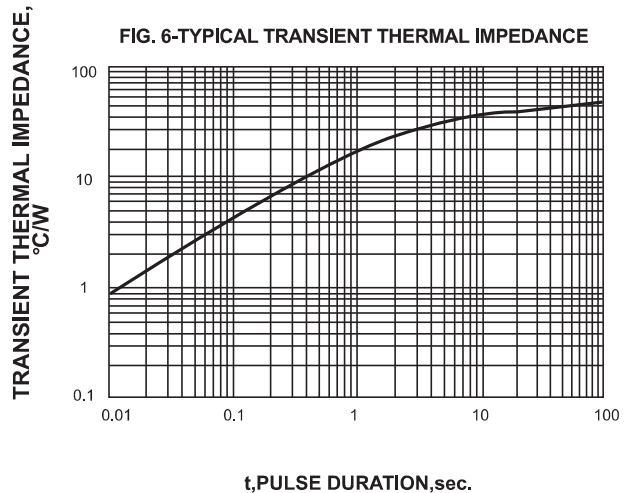
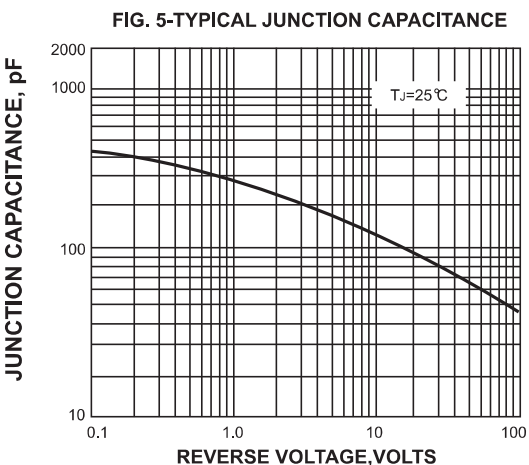
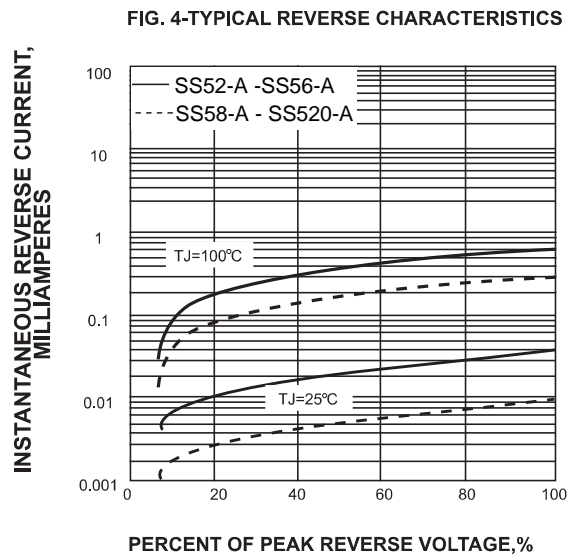
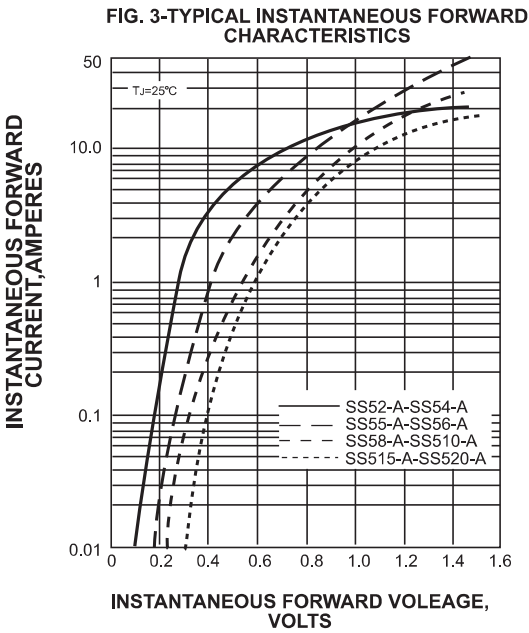
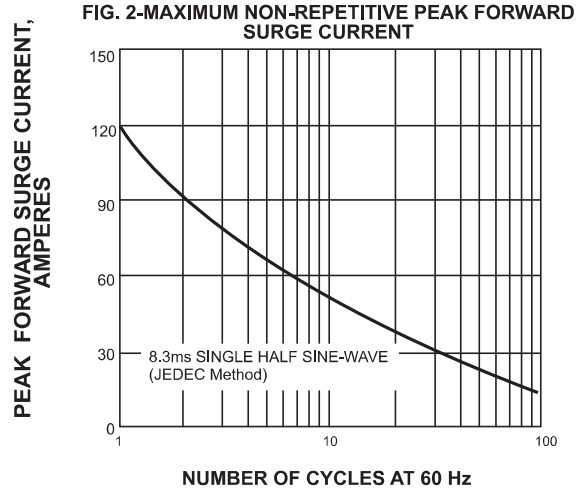
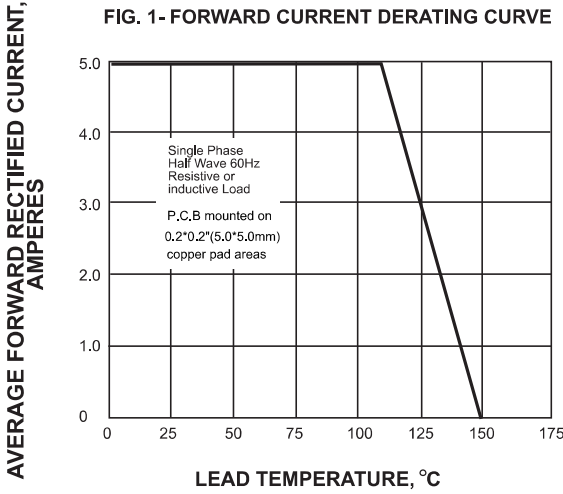
Rating and characteristic curves



Pinning information

Pin	Simplified outline	Symbol
Pin1 cathode Pin2 anode		

Marking

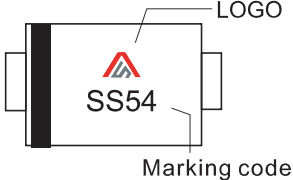
Type number	Marking code	Example
SS52-A	SS52	
SS53-A	SS53	
SS54-A	SS54	
SS55-A	SS55	
SS56-A	SS56	
SS58-A	SS58	
SS510-A	SS510	
SS515-A	SS515	
SS520-A	SS520	

Suggested solder pad layout

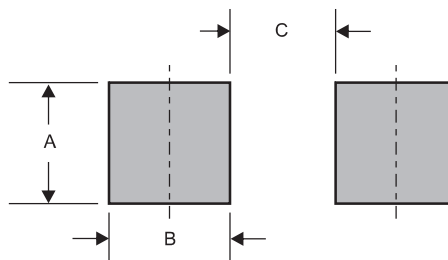

Dimensions in inches and (millimeters)

PACKAGE	A	B	C
SMA	0.110 (2.80)	0.063 (1.60)	0.087 (2.20)