

FEATURES

- ✧ 350 watts peak pulse power per line ($t_p=8/20\mu s$)
- ✧ Protects two I/O lines with uni-directional
- ✧ Low clamping voltage
- ✧ Working voltages: 5V
- ✧ Low leakage current
- ✧ Meet MSL 1 requirements
- ✧ RoHS compliant
- ✧ Compliant to Halogen - free

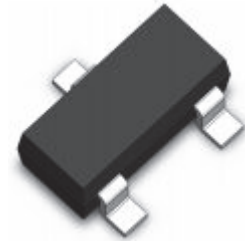

SOT-23

MAIN APPLICATIONS

- ✧ RS-232, RS-422 & RS-485
- ✧ Servers, notebook, and desktop
- ✧ Cellular handsets and accessories
- ✧ Control & monitoring systems
- ✧ Portable electronics
- ✧ Wireless bus protection
- ✧ Set-top box

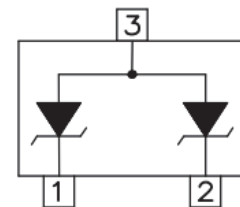

PIN Configuration

PROTECTION SOLUTION TO MEET

- ✧ IEC61000-4-2 (ESD) $\pm 15kV$ (air), $\pm 8kV$ (contact)
- ✧ IEC61000-4-4 (EFT) 40A (5/50ns)
- ✧ IEC61000-4-5 (lightning) 18A (8/20 μs)

MECHANICAL CHARACTERISTICS

- ✧ SOT-23 package
- ✧ Molding compound flammability rating: UL 94V-0
- ✧ Quantity per reel: 3,000pcs
- ✧ Reel size: 7 inch
- ✧ Lead finish: lead free
- ✧ Marking code: 5M2

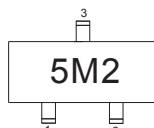

ABSOLUTE MAXIMUM RATINGS ($T_A=25^{\circ}\text{C}$, RH=45%-75%, unless otherwise noted)

Parameter	Symbol	Value	Unit
Peak pulse power dissipation on 8/20 μs waveform	P_{PP}	350	W
ESD per IEC 61000-4-2 (Air)	V_{ESD}	+/- 15	kV
ESD per IEC 61000-4-2 (Contact)		+/- 8	
Lead soldering temperature	T_L	260 (10 sec.)	$^{\circ}\text{C}$
Operating junction temperature range	T_J	-55 to +125	$^{\circ}\text{C}$
Storage temperature range	T_{STG}	-55 to +150	$^{\circ}\text{C}$

ELECTRICAL CHARACTERISTICS ($T_A=25^{\circ}\text{C}$)

Parameter	Symbol	Conditions	Min	Typ	Max	Unit
Reverse working voltage	V_{RWM}				5.0	V
Reverse breakdown voltage	V_{BR}	$I_T = 1\text{mA}$	6.0			V
Reverse leakage current	I_R	$V_{RWM} = 5\text{V}$			1	μA
Clamping voltage	V_C	$I_{PP}^{(1)} = 1\text{A}$, $t_p=8/20\mu\text{s}$			9.8	V
		$I_{PP}^{(1)} = 18\text{A}$, $t_p=8/20\mu\text{s}$			16.7	V
Junction capacitance	$C_J^{(2)}$	$V_{RWM} = 0\text{V}$, $f = 1\text{MHz}$		150	180	pF

① Surge waveform: 8/20 μs

② C_J measured @ $V_{RWM}=0\text{V}$, 1MHz (pin1 to pin3, pin2 to pin3)

RATINGS AND V-I CHARACTERISTICS CURVES ($T_A=25^{\circ}\text{C}$, unless otherwise noted)

FIG.1: V- I curve characteristics (Uni-directional)

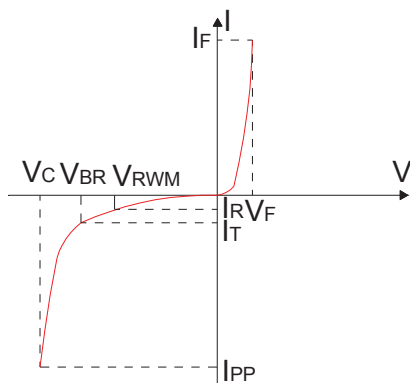

FIG.2: Pulse waveform (8/20 μs)

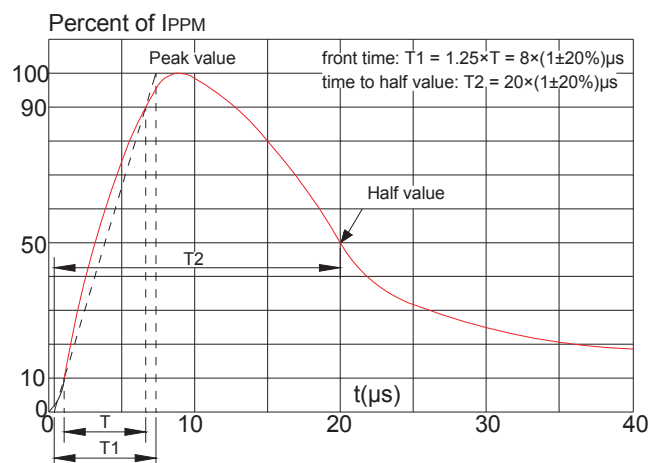

FIG.3: Pulse derating curve

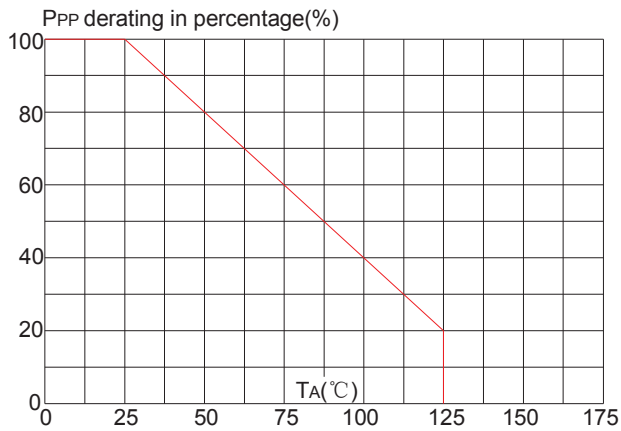
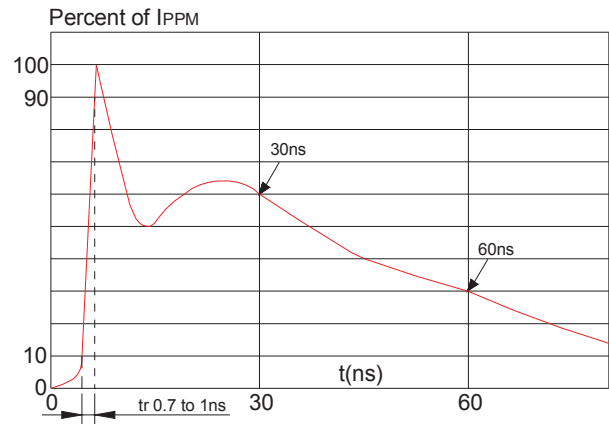
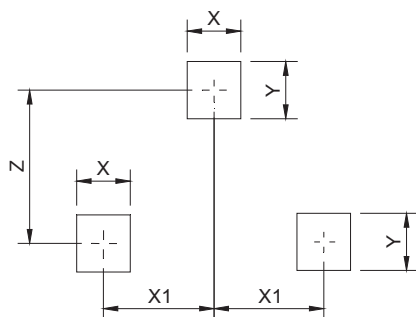
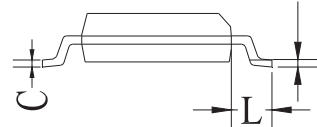
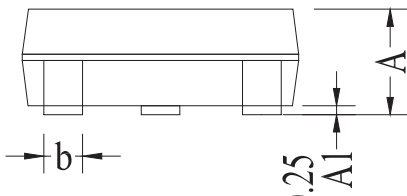
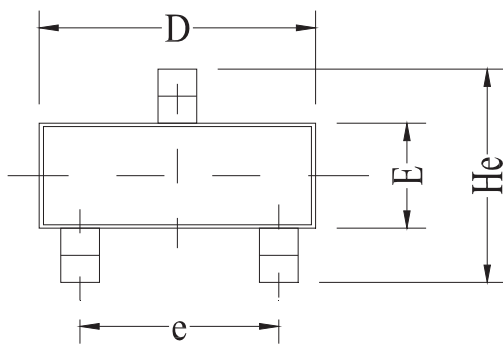

FIG.4: ESD clamping (8KV contact)



PACKAGE MECHANICAL DATA



Land Pattern

Symbol	Millimeter		Inches	
	Min	Max	Min	Max
A	0.9	1.15	0.035	0.045
A1	0.00	0.10	0.000	0.004
b	0.25	0.325	0.01	0.013
C	0.22	0.25	0.009	0.01
D	2.8	3.0	0.11	0.118
e	1.8	1.9	0.071	0.075
E	1.2	1.4	0.047	0.055
L	0.30	0.50	0.012	0.02
He	2.25	2.55	0.089	0.1
X	0.8		0.0315	
X1	0.95		0.037	
Y	0.80		0.0315	
Z	2.02		0.0795	