

Features

- High collector-emitter breakdown voltage.
- PNP silicon epitaxial planar transistor, is designed for general purpose and amplifier applications.
- Capable of 225mW power dissipation.
- Lead-free parts meet RoHS requirements.
- Compliant to Halogen-free

Mechanical data

- Epoxy: UL94-V0 rated flame retardant
- Case : Molded plastic, SOT-23
- Terminals : Solder plated, solderable per MIL-STD-750, Method 2026
- Mounting Position : Any

Package outline

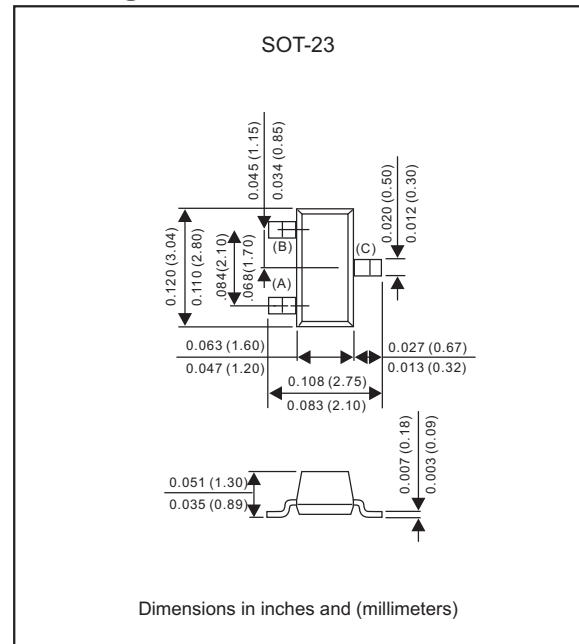

Maximum ratings (AT $T_A=25^\circ\text{C}$ unless otherwise noted)

PARAMETER	Symbol	MMBT2907	MMBT2907A	UNIT
Collector-emitter voltage	V_{CE0}	-40	-60	V
Collector-base voltage	V_{CBO}	-60		V
Emitter-base voltage	V_{EBO}	-5.0		V
Collector current - continuous	I_C	-600		mA
Total device dissipation FR-5 board (1)	P_D	$T_A = 25^\circ\text{C}$	225	mW
		Derate above 25°C	1.8	mW/ $^\circ\text{C}$
Thermal resistance	$R_{\theta JA}$	556		$^\circ\text{C}/\text{W}$
Total device dissipation alumina substrate(2)	P_D	$T_A = 25^\circ\text{C}$	300	mW
		Derate above 25°C	2.4	mW/ $^\circ\text{C}$
Thermal resistance	$R_{\theta JA}$	417		$^\circ\text{C}/\text{W}$
Operating junction temperature range	T_J	-55 to +150		$^\circ\text{C}$
Storage temperature range	T_{STG}	-55 to +150		$^\circ\text{C}$

1.FR-5 = 1.0 X 0.75 X 0.062 in.

2.Alumina = 0.4 X 0.3 X 0.024 in. 99.5% alumina.

ELECTRICAL CHARACTERISTICS (TA = 25°C unless otherwise noted)

Characteristics		Symbol	Min	Max	Unit
OFF CHARACTERISTICS					
Collector-Emitter Breakdown Voltage (IC= -10 mAdc, IB=0)	MMBT2907 MMBT2907A	V(BR)CEO	-40 -60	- -	Vdc
Collector-Base Breakdown Voltage (IC= -10 uAdc, IE=0)		V(BR)CBO	-60	-	Vdc
Emitter-Base Breakdown Voltage (IE= -10 uAdc, IC=0)		V(BR)EBO	-5.0	-	Vdc
Collector Cutoff Current (VCE= -30 Vdc, VEB(off) = -0.5Vdc)		ICEX	-	-50	nAdc
Collector Cutoff Current (VCB= -50 Vdc, IE=0)	MMBT2907 MMBT2907A	ICBO	-	-0.020	uAdc
(VCB= -50Vdc, IE=0, TA=125°C)	MMBT2907		-	-0.010	
	MMBT2907A		-	-20	
Base Cutoff Current (VCE= -30Vdc, VEB(off) = -0.5Vdc)	MMBT2907A	IB	-	-50	nAdc

ELECTRICAL CHARACTERISTICS (TA = 25°C unless otherwise noted) (Continued)

Characteristics		Symbol	Min	Max	Unit
ON CHARACTERISTICS					
DC Current Gain	MMBT2907 MMBT2907A	hFE	35 75	-	
(IC= -0.1 mAdc, VCE= -10 Vdc)					
(IC= -1.0 mAdc, VCE= -10 Vdc)			50 100	- -	
(IC= -10 mAdc, VCE= -10 Vdc)			75 100	- -	
(IC= -150 mAdc, VCE= -10 Vdc)			- 100	- 300	
(IC= -500 mAdc, VCE= -10 Vdc)			30 50	- -	
Collector-Emitter Saturation Voltage (IC= -150 mAdc, IB= -15mAdc) (IC= -500 mAdc, IB= -50mAdc)		VCE(sat)	- -	-0.4 -1.6	Vdc
Base-Emitter Saturation Voltage (IC= -150 mAdc, IB= -15mAdc) (IC= -500 mAdc, IB= -50mAdc)		VBE(sat)	- -	-1.3 -2.6	Vdc

ELECTRICAL CHARACTERISTICS (T_A = 25°C unless otherwise noted) (Continued)

Characteristics	Symbol	Min	Max	Unit
SMALL-SIGNAL CHARACTERISTICS				
Current-Gain-Bandwidth Product (1),(2) (I _C = -50 mA, V _{CE} = 20 Vdc, f = 100MHz)	f _T	200	-	MHz
Output Capacitance (V _{CB} = -10 Vdc, I _E = 0, f = 1.0MHz)	C _{obo}	-	8.0	pF
Input Capacitance (V _{EB} = -2.0 Vdc, I _C = 0, f = 1.0MHz)	C _{ibo}	-	30	pF

SWITCHING CHARACTERISTICS

Turn-On Time	(V _{CC} = -30 Vdc, I _C = -150 mA, I _{B1} = -15 mA)	t _{on}	-	45	ns
Delay Time		t _d	-	10	
Rise Time		t _r	-	40	
Turn-Off Time	(V _{CC} = -6V, I _C = -150mA, I _{B1} = -I _{B2} = -15mA)	t _{off}	-	100	
Storage Time		t _s	-	225	
Fall Time		t _f	-	60	

1. Pulse Test: Pulse Width ≤ 300 μs, Duty Cycle ≤ 2.0%.
2. f_T is defined as the frequency at which |h_{fe}| extrapolates to unity.

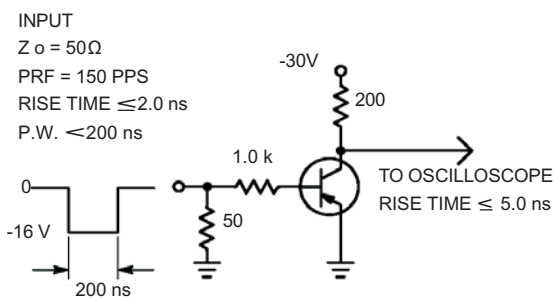

Figure 1. Delay and Rise Time Test Circuit

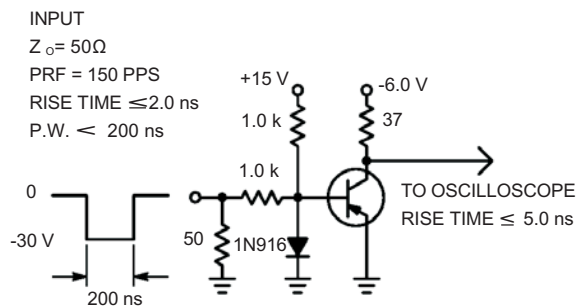

Figure 2. Storage and Fall Time Test Circuit

Rating and characteristic curves

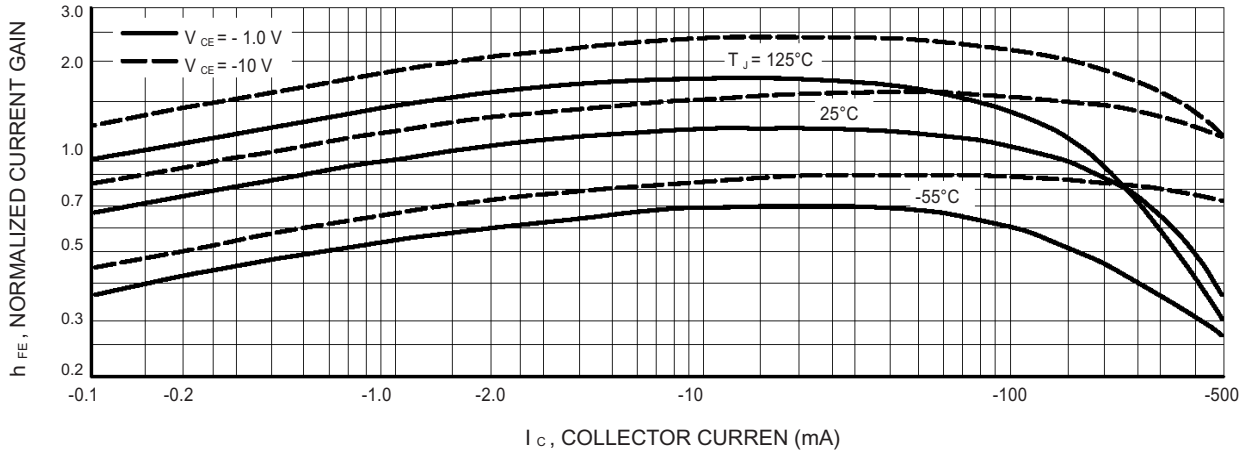

Figure 3. DC Current Gain

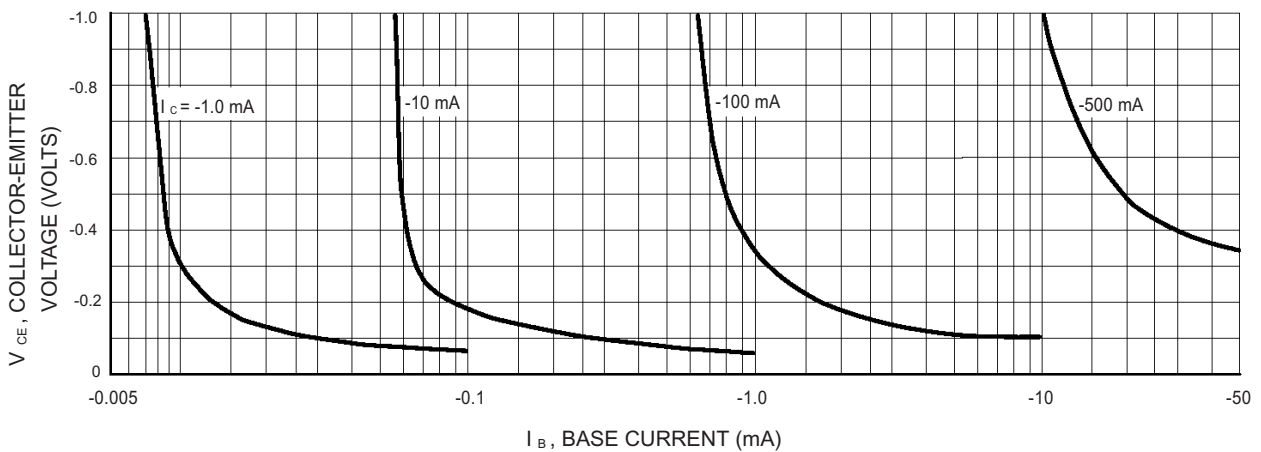

Figure 4. Collector Saturation Region

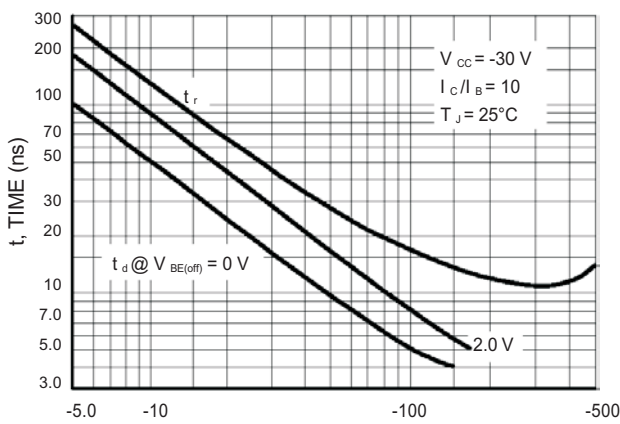

Figure 5. Turn-On Time

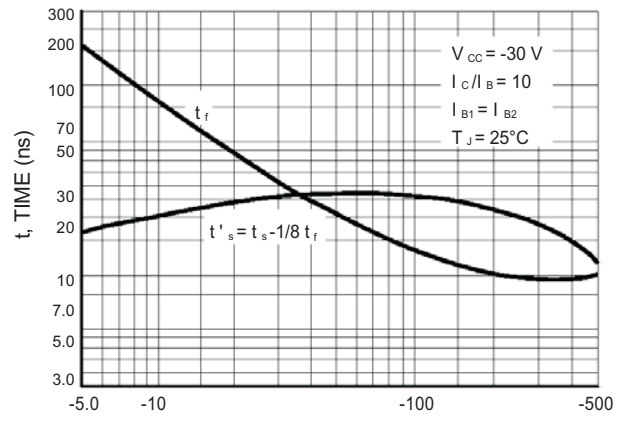

Figure 6. Turn-off Time

Rating and characteristic curves

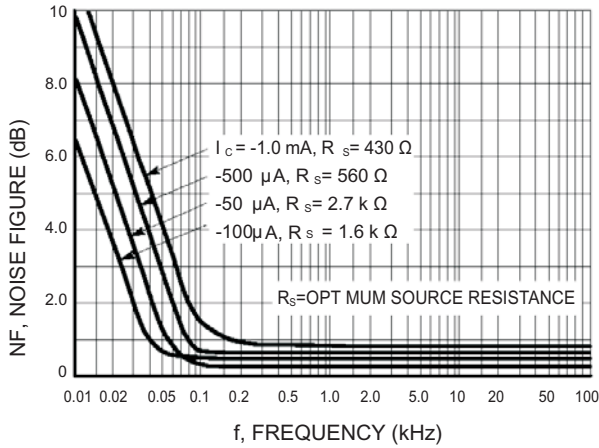

Figure 7. Frequency Effects

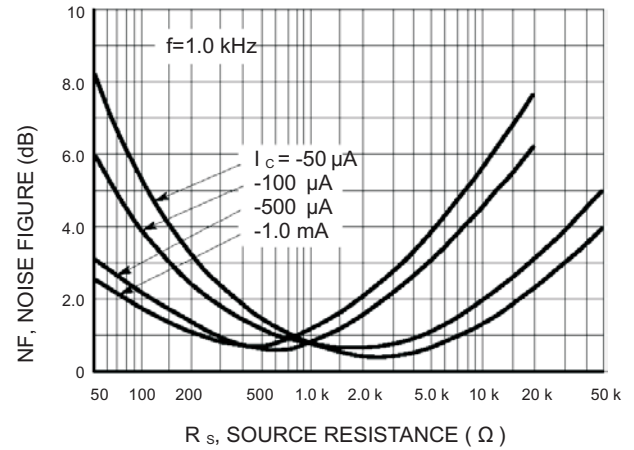

Figure 8. Source Resistance Effects

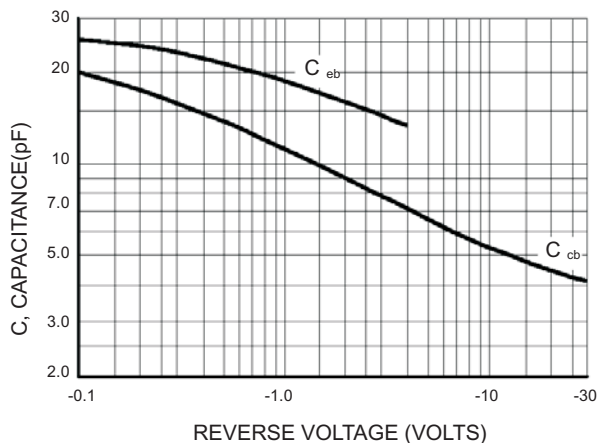

Figure 9. Capacitances

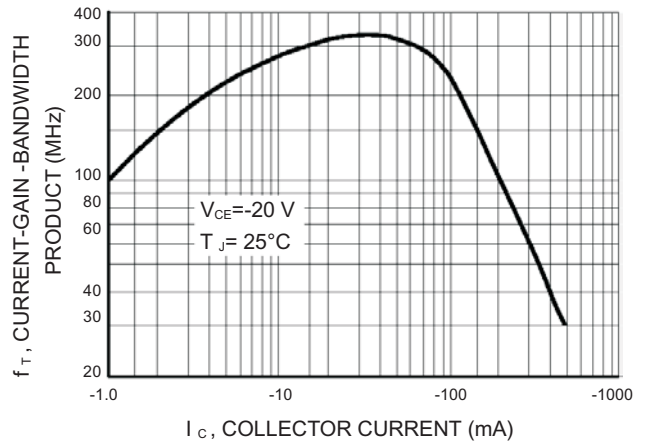

Figure 10. Current-Gain-Bandwidth Product

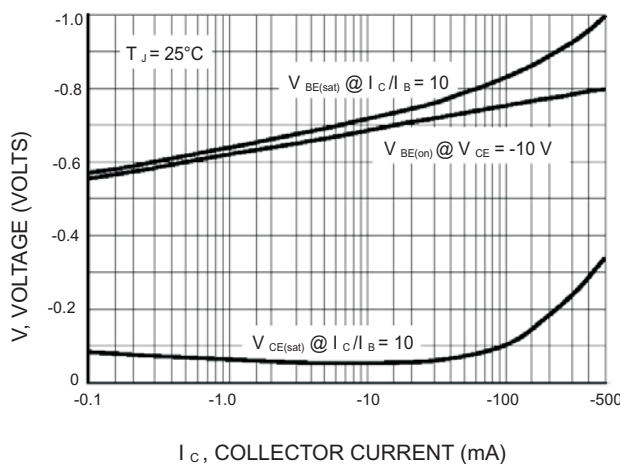

Figure 11. "On" Voltage

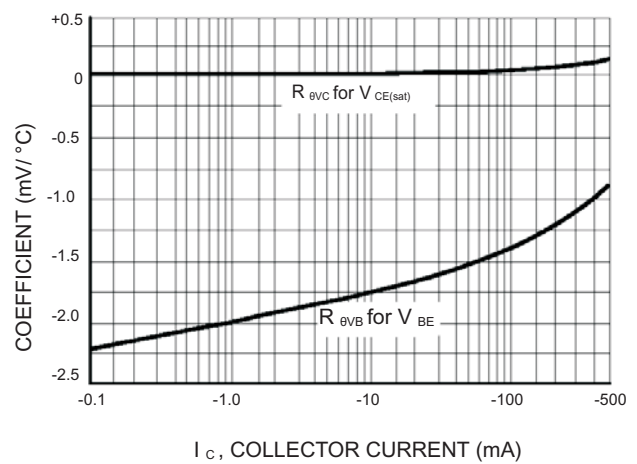
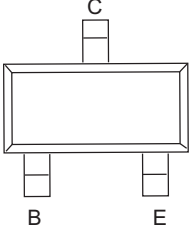
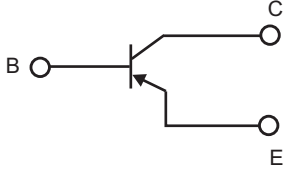

Figure 12. Temperature Coefficients

Pinning information

Pin	Simplified outline	Symbol
PinB Base PinC Collector PinE Emitter		

Marking

Type number	Marking code
MMBT2907	M2B
MMBT2907A	2F

Suggested solder pad layout

SOT-23

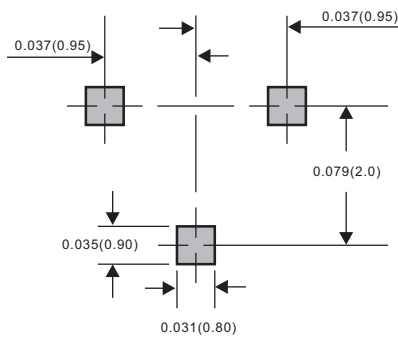

Dimensions in inches and (millimeters)