

Features

- Fast switching speed
- For general purpose switching applications
- High conductance
- Lead-free parts meet RoHS requirements
- Compliant to Halogen-free
- Suffix "-Q1" for AEC-Q101

Mechanical data

- Epoxy:UL94-V0 rated flame retardant
- Case : Molded plastic, SOT-23
- Terminals : Solder plated, solderable per MIL-STD-750, Method 2026
- Mounting Position : Any

Package Outline

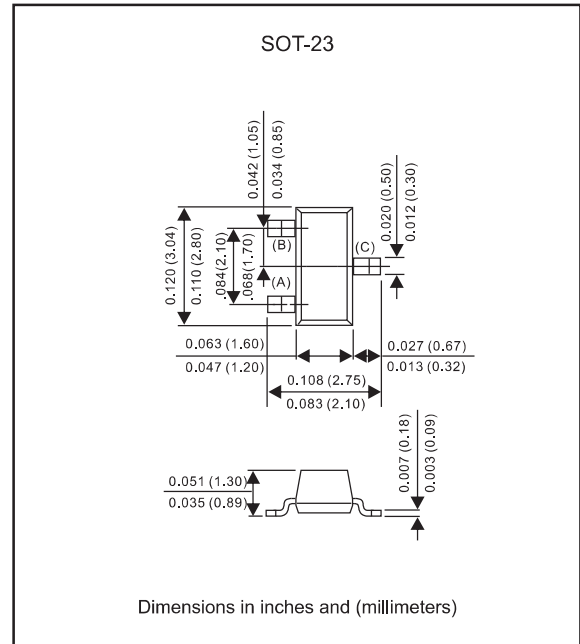

Maximum ratings (AT $T_A=25^\circ\text{C}$ unless otherwise noted)

PARAMETER	Symbol	Limit	UNIT
Non-Repetitive Peak Reverse Voltage	V_{RM}	100	V
Peak Repetitive Peak Reverse Voltage	V_{RRM}	75	V
Working Peak Reverse Voltage	V_{RWM}		
DC Blocking Voltage	V_R		
RMS Reverse Voltage	$V_{R(RMS)}$	53	V
Forward continuous current	I_{FM}	300	mA
Average rectified output current (note 1)	I_O	150	mA
Non-repetitive peak forward surge current 8.3ms	I_{FSM}	2.0	A
Power dissipation (note 1)	P_D	350	mW
Thermal resistance junction to ambient (note 1)	$R_{\theta JA}$	357	$^\circ\text{C/W}$
Operating junction temperature range	T_J	-55 to +150	$^\circ\text{C}$
Storage temperature range	T_{STG}	-55 to +150	$^\circ\text{C}$

Electrical characteristics (AT $T_A=25^\circ\text{C}$ unless otherwise noted)

PARAMETER	CONDITION	Symbol	MIN.	TYP.	MAX.	UNIT
Reverse breakdown voltage	$I_R = 100\mu\text{A}$	$V_{(BR)R}$	75			V
Forward voltage	$I_F = 1\text{ mA}$ $I_F = 10\text{ mA}$ $I_F = 50\text{ mA}$ $I_F = 150\text{ mA}$	V_F			0.715 0.855 1.000 1.250	V
Reverse leakage current	$V_R = 20\text{V}, T_J=25^\circ\text{C}$ $V_R = 75\text{V}, T_J=25^\circ\text{C}$	I_R			25 2.5	nA μA
Capacitance between terminals	$V_R=0, f=1\text{MHz}$	C_T			2.0	pF
Reverse recovery time	$I_F=I_R=10\text{mA}$ $I_{rr}=0.1I_R, R_L=100\Omega$	t_{rr}			4.0	ns

Note 1: Valid provided that electrodes are kept at ambient temperature.

Rating and characteristic curves (MMBD4148/CA/CC/SE-Q1)

Forward Characteristics

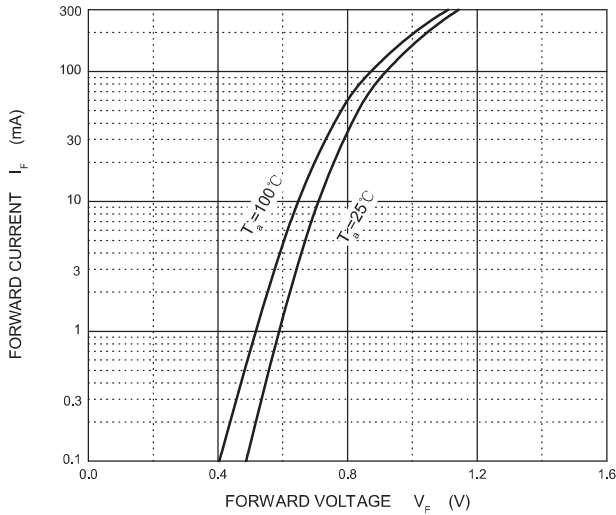

Reverse Characteristics

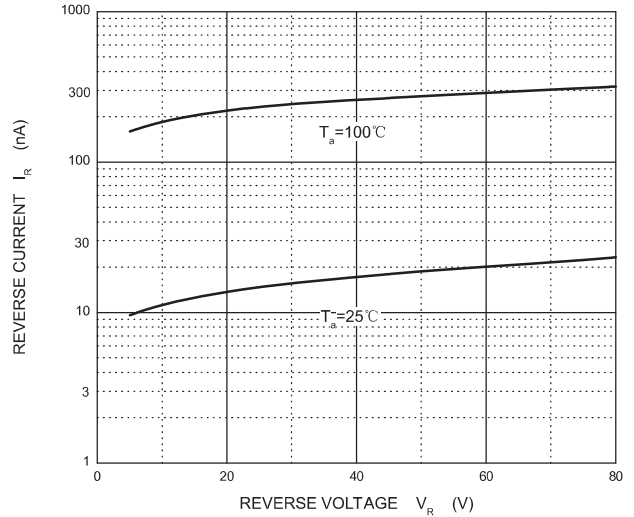

Capacitance Characteristics

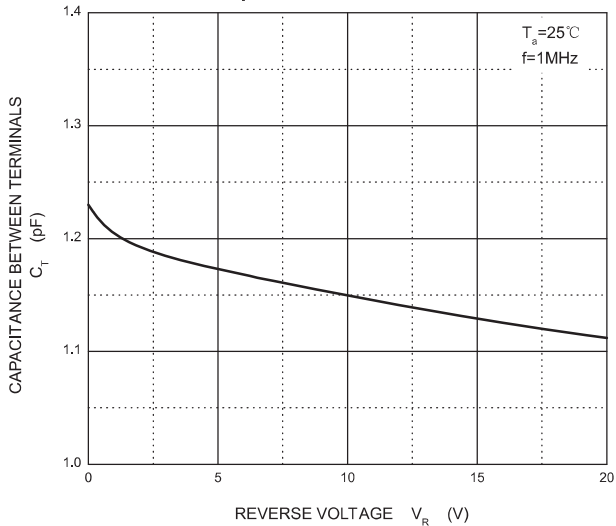

Power Derating Curve

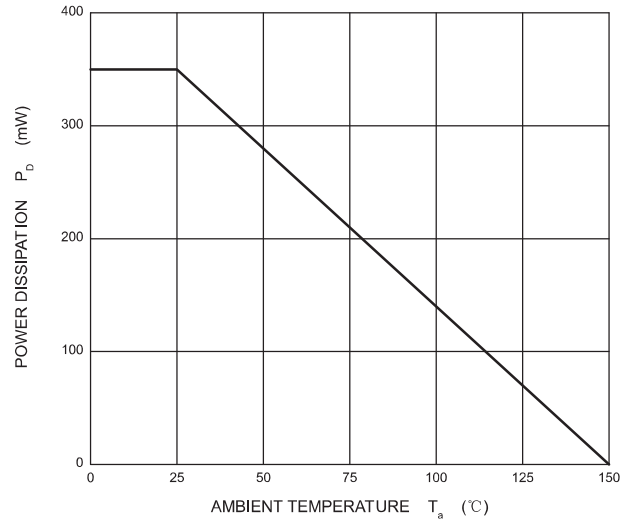

Pinning information

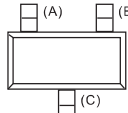
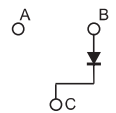
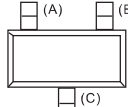
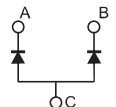
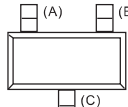
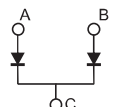
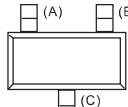
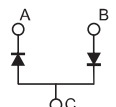
Type number	Marking code	Simplified outline	Symbol
MMBD4148-Q1	A6/KA2		
MMBD4148CA-Q1	D6		
MMBD4148CC-Q1	D5/KD5		
MMBD4148SE-Q1	D4		

Suggested solder pad layout

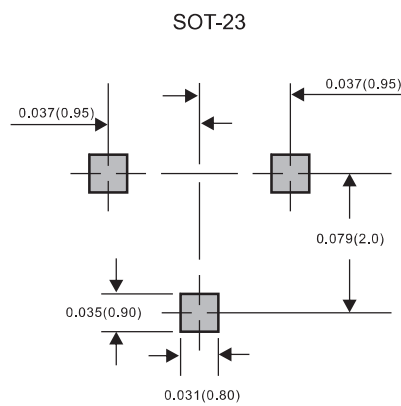

Dimensions in inches and (millimeters)