

### Features

- Low power loss, high efficiency.
- High current capability
- High surge capability.
- Guardring for overvoltage protection.
- Low stored charge majority carrier conduction
- Silicon epitaxial planar chip, metal silicon junction.
- Lead-free parts meet environmental standards of MIL-STD-19500 /228
- Suffix "-H" indicates Halogen-free parts, ex. MBR3040FCT-H.

### Mechanical data

- Epoxy : UL94-V0 rated flame retardant
- Case : JEDEC ITO-220AB molded plastic body over passivated chip
- Lead : Axial leads, solderable per MIL-STD-202, Method 208 guaranteed
- Polarity: As marked
- Mounting Position : Any

### Package outline

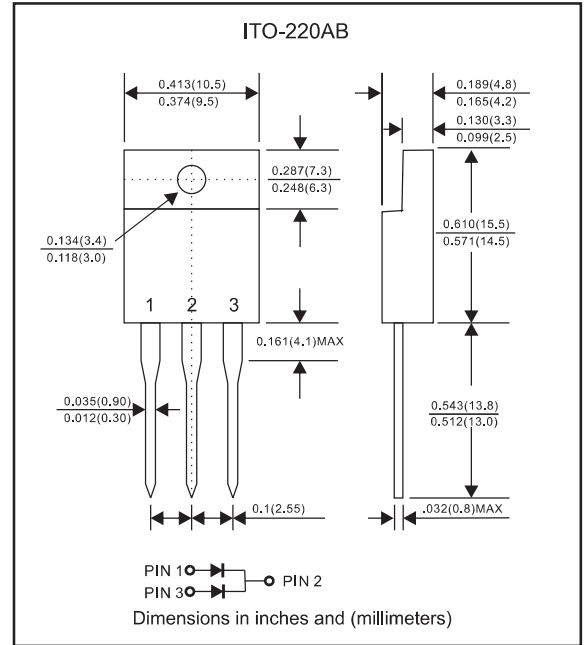

### Maximum ratings and Electrical Characteristics (AT $T_A=25^\circ\text{C}$ unless otherwise noted)

PARAMETER	CONDITIONS	Symbol	MIN.	TYP.	MAX.	UNIT
Forward rectified current	See Fig.1	$I_O$			30.0	A
Forward surge current	8.3ms single half sine-wave (JEDEC methode)	$I_{FSM}$			200	A
Reverse current	$V_R = V_{RRM} T_J = 25^\circ\text{C}$	$I_R$			0.05	mA
	$V_R = V_{RRM} T_J = 125^\circ\text{C}$				15	
Thermal resistance	Junction to case	$R_{\theta JC}$		1.4		$^\circ\text{C/W}$
Storage temperature		$T_{STG}$	-65		+175	$^\circ\text{C}$

SYMBOLS	$V_{RRM}^{*1}$ (V)	$V_{RMS}^{*2}$ (V)	$V_R^{*3}$ (V)	$V_F^{*4}$ (V)	Operating temperature $T_J$ , ( $^\circ\text{C}$ )
MBR3040FCT	40	28	40	0.70	-55 to +150
MBR3045FCT	45	31.5	45		
MBR3050FCT	50	35	50	0.80	
MBR3060FCT	60	42	60		
MBR3080FCT	80	56	80	0.85	-55 to +175
MBR30100FCT	100	70	100		
MBR30150FCT	150	105	150	0.92	
MBR30200FCT	200	140	200		

\*1 Repetitive peak reverse voltage

\*2 RMS voltage

\*3 Continuous reverse voltage

\*4 Maximum forward voltage  
 $I_F = 15.0\text{A}$ ,  $25^\circ\text{C}$

## Rating and characteristic curves (MBR3040FCT THRU MBR30200FCT)

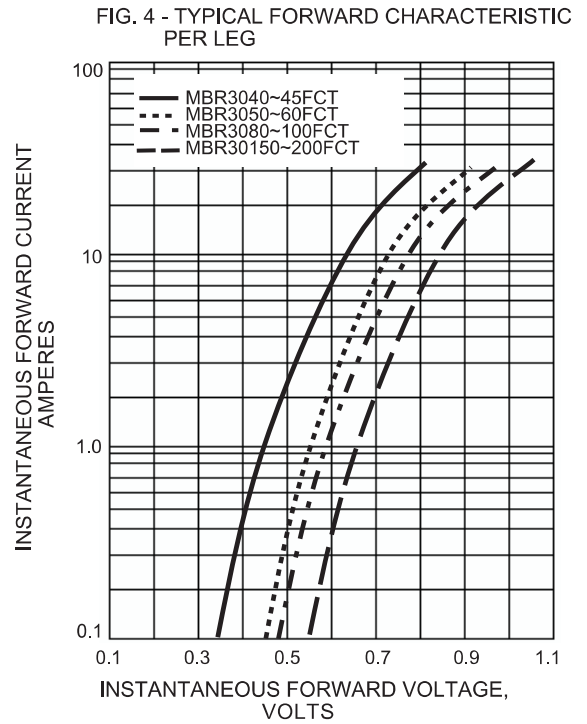
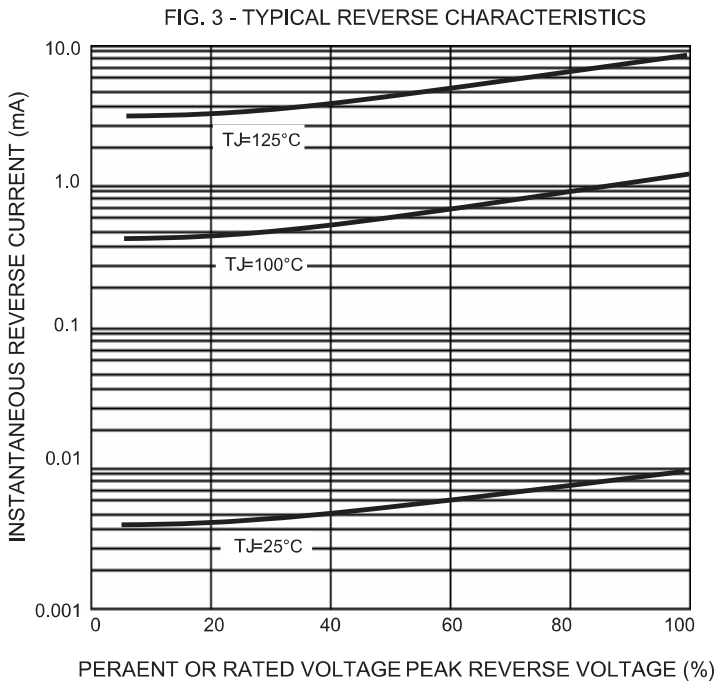
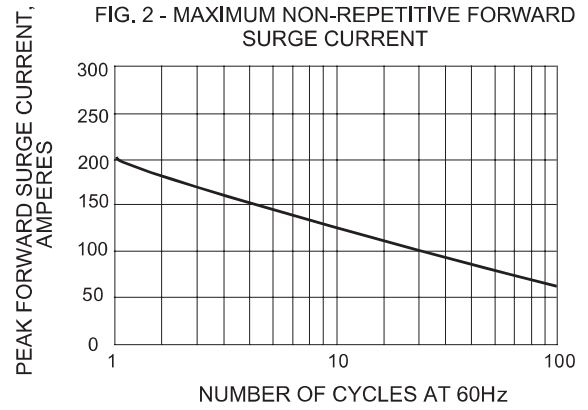
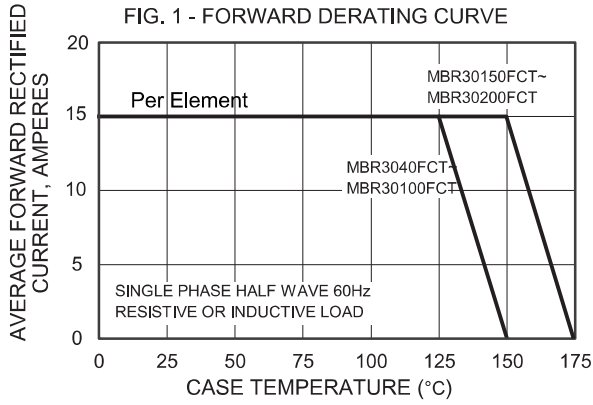

### Pinning information

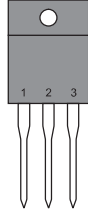
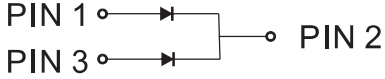
Pin	Simplified outline	Symbol
Pin1 anode Pin2 cathode Pin3 anode		

### Marking

Type number	Marking code
MBR3040FCT	MBR3040FCT
MBR3045FCT	MBR3045FCT
MBR3050FCT	MBR3050FCT
MBR3060FCT	MBR3060FCT
MBR3080FCT	MBR3080FCT
MBR30100FCT	MBR30100FCT
MBR30150FCT	MBR30150FCT
MBR30200FCT	MBR30200FCT