

### Features

- Low power loss, high efficiency.
- High current capability
- High surge capability.
- Guardring for overvoltage protection.
- Low stored charge majority carrier conduction
- Silicon epitaxial planar chip, metal silicon junction.
- Lead-free parts meet environmental standards of MIL-STD-19500 /228
- Suffix "-H" indicates Halogen-free parts, ex. MBR2040CT-H.

### Mechanical data

- Epoxy : UL94-V0 rated flame retardant
- Case : JEDEC TO-220AB molded plastic body over passivated chip
- Lead : Axial leads, solderable per MIL-STD-202, Method 208 guranteed
- Polarity: As marked
- Mounting Position : Any

### Package outline

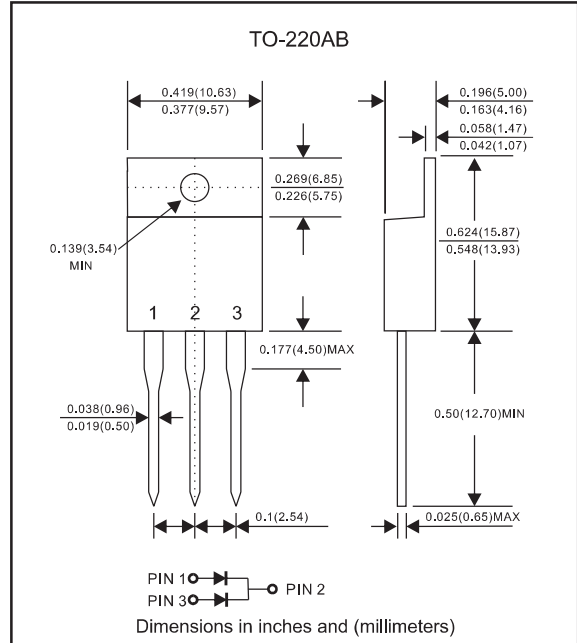

### Maximum ratings and Electrical Characteristics (AT $T_A=25^\circ\text{C}$ unless otherwise noted)

PARAMETER	CONDITIONS	Symbol	MIN.	TYP.	MAX.	UNIT
Forward rectified current	See Fig.1	$I_O$			20.0	A
Forward surge current	8.3ms single half sine-wave (JEDEC methode)	$I_{FSM}$			150	A
Reverse current	$V_R = V_{RRM} T_J = 25^\circ\text{C}$	$I_R$			0.05	mA
	$V_R = V_{RRM} T_J = 125^\circ\text{C}$				10	
Thermal resistance (1)	Junction to case	$R_{BJC}$		2		$^\circ\text{C}/\text{W}$
Storage temperature		$T_{STG}$	-65		+175	$^\circ\text{C}$

NOTE : (1) Device mounted on additional heatsink, (50mm x 50mm x 23mm Al heatsink).

SYMBOLS	$V_{RRM}^{*1}$ (V)	$V_{RMS}^{*2}$ (V)	$V_R^{*3}$ (V)	$V_F^{*4}$ (V)	Operating temperature $T_J$ , ( $^\circ\text{C}$ )
MBR2040CT	40	28	40	0.70	-55 to +150
MBR2045CT	45	31.5	45		
MBR2050CT	50	35	50	0.80	
MBR2060CT	60	42	60		
MBR2080CT	80	56	80	0.85	-55 to +175
MBR20100CT	100	70	100		
MBR20150CT	150	105	150	0.92	
MBR20200CT	200	140	200		

\*1 Repetitive peak reverse voltage

\*2 RMS voltage

\*3 Continuous reverse voltage

\*4 Maximum forward voltage  
IF = 10.0A, 25 $^\circ\text{C}$

## Rating and characteristic curves (MBR2040CT THRU MBR20200CT)

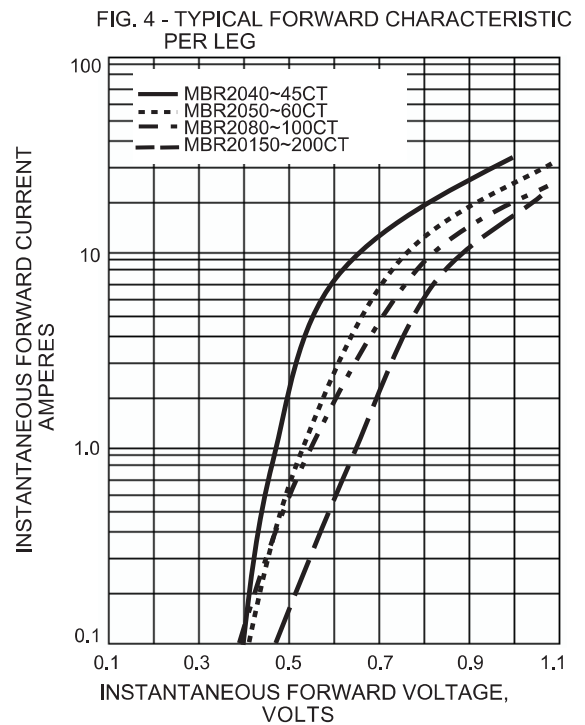
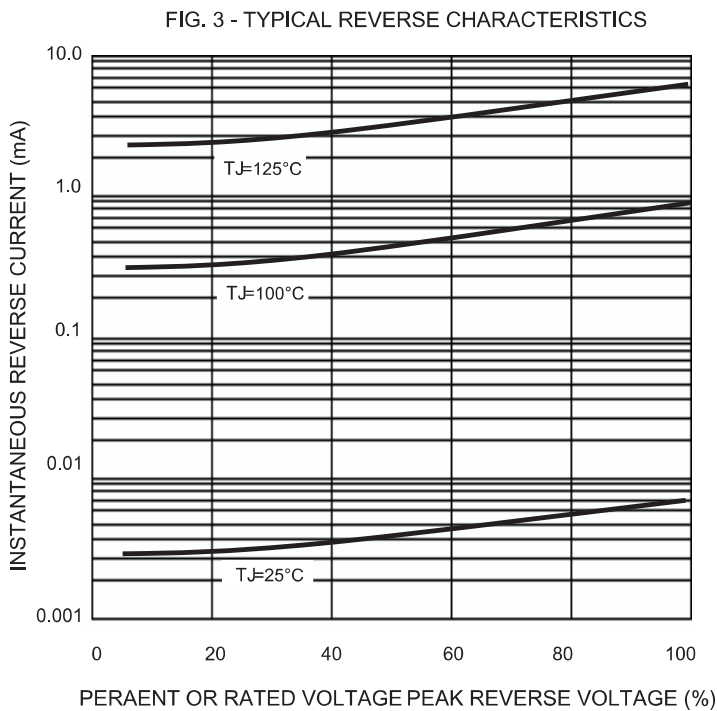
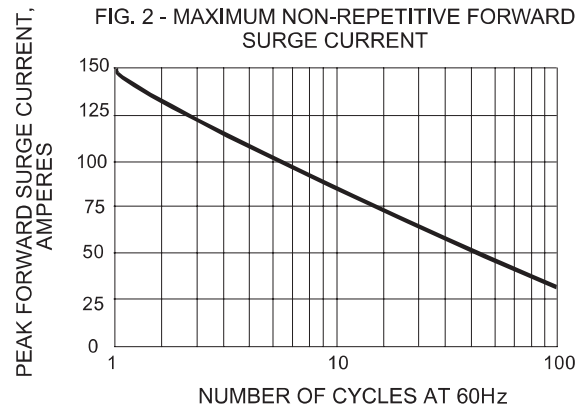
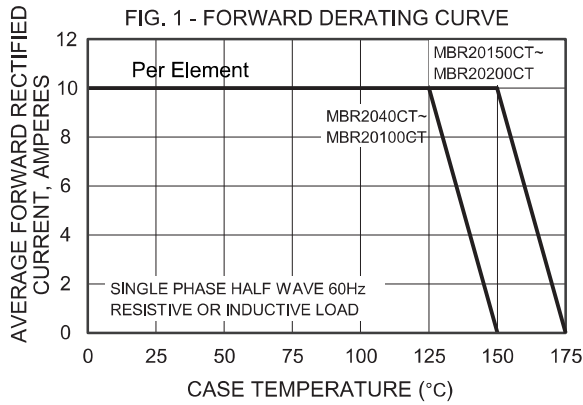

### Pinning information

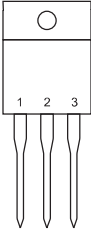
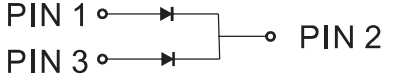
Pin	Simplified outline	Symbol
Pin1 anode Pin2 cathode Pin3 anode		

### Marking

Type number	Marking code
MBR2040CT	MBR2040CT
MBR2045CT	MBR2045CT
MBR2050CT	MBR2050CT
MBR2060CT	MBR2060CT
MBR2080CT	MBR2080CT
MBR20100CT	MBR20100CT
MBR20150CT	MBR20150CT
MBR20200CT	MBR20200CT