

Features

- Low power loss, high efficiency.
- High current capability
- High surge capability.
- Guardring for overvoltage protection.
- Low stored charge majority carrier conduction
- Silicon epitaxial planar chip, metal silicon junction.
- Lead-free parts meet environmental standards of MIL-STD-19500 /228
- Suffix "-H" indicates Halogen-free parts, ex. MBR2040FCT-H.

Mechanical data

- Epoxy : UL94-V0 rated flame retardant
- Case : JEDEC ITO-220AB molded plastic body over passivated chip
- Lead : Axial leads, solderable per MIL-STD-202, Method 208 guaranteed
- Polarity: Color band denotes cathode end
- Mounting Position : Any

Package outline

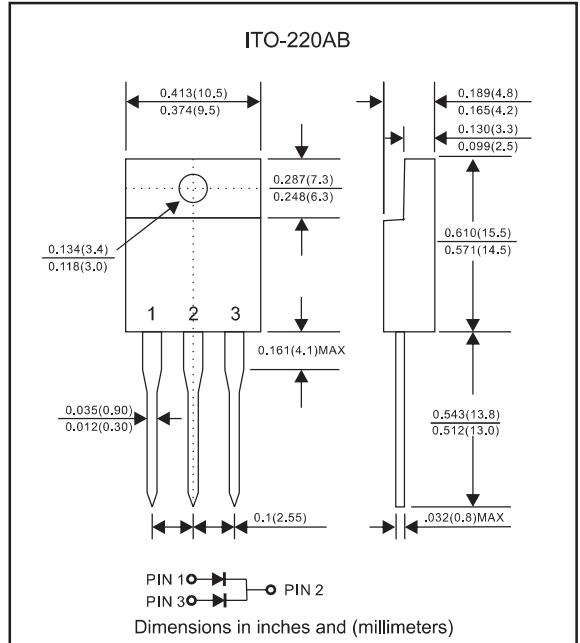

Maximum ratings and Electrical Characteristics (AT $T_A=25^{\circ}\text{C}$ unless otherwise noted)

PARAMETER	CONDITIONS	Symbol	MIN.	TYP.	MAX.	UNIT
Forward rectified current	See Fig.1	I_o			20.0	A
Forward surge current	8.3ms single half sine-wave (JEDEC methode)	I_{FSM}			150	A
Reverse current	$V_R = V_{RRM} T_J = 25^{\circ}\text{C}$	I_R			0.05	mA
	$V_R = V_{RRM} T_J = 125^{\circ}\text{C}$				10	
Thermal resistance	Junction to case	R_{BJC}		2.0		$^{\circ}\text{C}/\text{W}$
Storage temperature		T_{STG}	-65		+175	$^{\circ}\text{C}$

SYMBOLS	V_{RRM}^{*1} (V)	V_{RMS}^{*2} (V)	V_R^{*3} (V)	V_F^{*4} (V)	Operating temperature T_J , ($^{\circ}\text{C}$)
MBR2040FCT	40	28	40	0.70	-55 to +150
MBR2045FCT	45	31.5	45		
MBR2050FCT	50	35	50	0.80	
MBR2060FCT	60	42	60		
MBR2080FCT	80	56	80	0.85	
MBR20100FCT	100	70	100		
MBR20150FCT	150	105	150	0.92	-55 to +175
MBR20200FCT	200	140	200		

*1 Repetitive peak reverse voltage

*2 RMS voltage

*3 Continuous reverse voltage

*4 Maximum forward voltage
IF = 10.0A

Rating and characteristic curves (MBR2040FCT THRU MBR20200FCT)

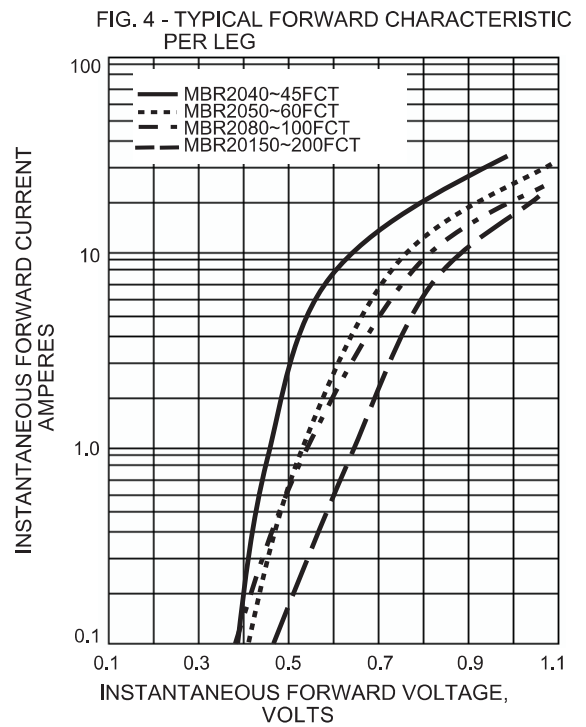
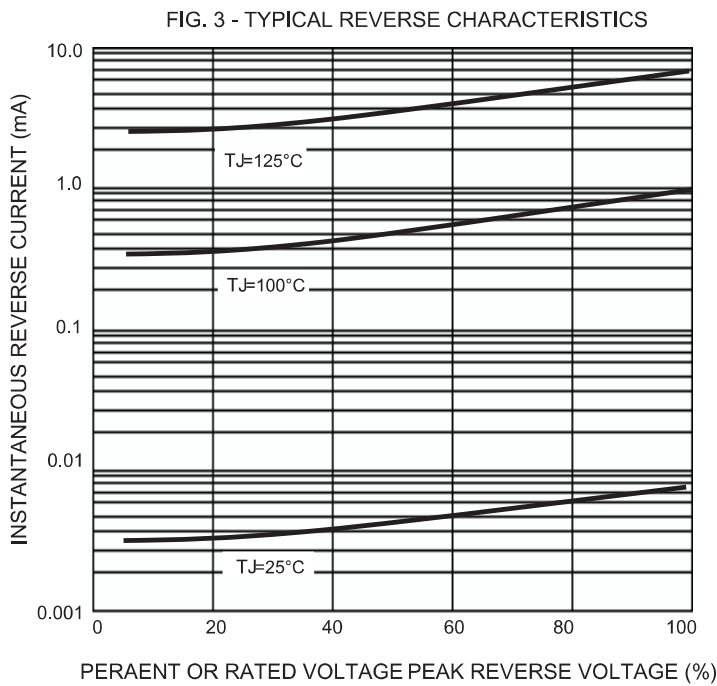
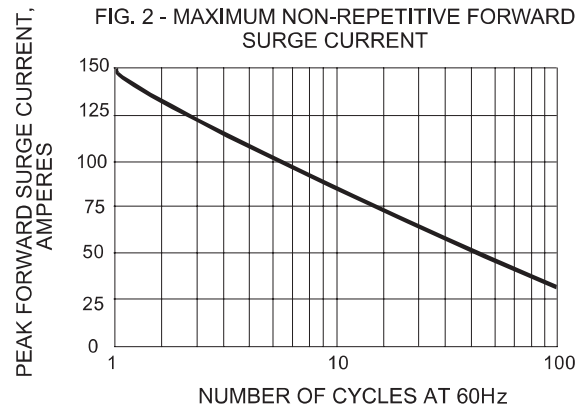
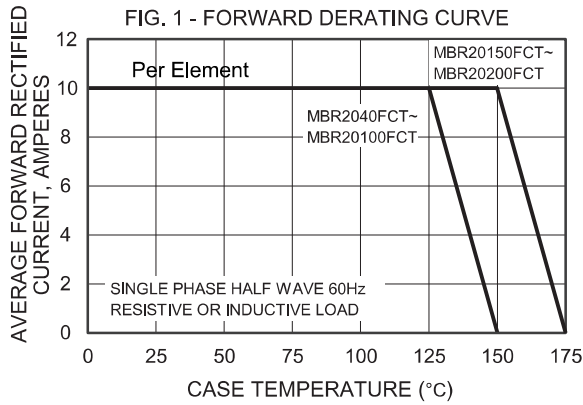

Pinning information

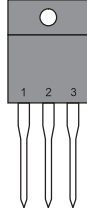
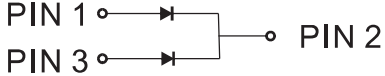
Pin	Simplified outline	Symbol
Pin1 anode Pin2 cathode Pin3 anode		

Marking

Type number	Marking code
MBR2040FCT	MBR2040FCT
MBR2045FCT	MBR2045FCT
MBR2050FCT	MBR2050FCT
MBR2060FCT	MBR2060FCT
MBR2080FCT	MBR2080FCT
MBR20100FCT	MBR20100FCT
MBR20150FCT	MBR20150FCT
MBR20200FCT	MBR20200FCT