

Features

- Batch process design, excellent power dissipation offers better reverse leakage current and thermal resistance.
- Low power loss, high efficiency.
- High current capability, low forward voltage drop.
- High surge capability.
- Guardring for overvoltage protection.
- Ultra high-speed switching.
- Silicon epitaxial planar chip, metal silicon junction.
- Lead-free parts meet environmental standards of MIL-STD-19500 /228
- Compliant to Halogen-free

Mechanical data

- Epoxy:UL94-V0 rated flame retardant
- Case : Molded plastic, TO-252AB/DPAK
- Terminals : Solder plated, solderable per MIL-STD-750, Method 2026
- Mounting Position : Any

Package outline

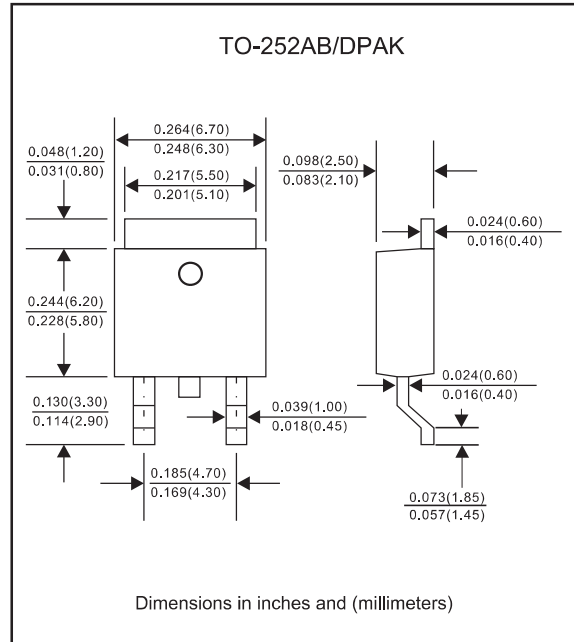

Maximum ratings and Electrical Characteristics (AT $T_A=25^\circ\text{C}$ unless otherwise noted)

PARAMETER	CONDITIONS	Symbol	MIN.	TYP.	MAX.	UNIT
Forward rectified current	See Fig.1	I_o			20.0	A
Forward surge current	8.3ms single half sine-wave (JEDEC methode)	I_{FSM}			120	A
Reverse current	$V_R = V_{RRM} T_J = 25^\circ\text{C}$	I_R			0.05	mA
	$V_R = V_{RRM} T_J = 125^\circ\text{C}$				10	
Diode junction capacitance	f=1MHz and applied 4V DC reverse voltage	C_J		560		pF
Thermal resistance (1)	Junction to Case	R_{BJC}		6		$^\circ\text{C}/\text{W}$
Storage temperature		T_{STG}	-65		+175	$^\circ\text{C}$

NOTE : (1) Device mounted on additional heatsink, (50mm x 50mm x 23mm Al heatsink).

SYMBOLS	V_{RRM}^{*1} (V)	V_{RMS}^{*2} (V)	V_R^{*3} (V)	V_F^{*4} (V)	Operating temperature T_J , ($^\circ\text{C}$)
MBR2040CD	40	28	40	0.70	-55 to +150
MBR2045CD	45	31.5	45		
MBR2050CD	50	35	50	0.80	
MBR2060CD	60	42	60		
MBR2080CD	80	56	80	0.85	
MBR20100CD	100	70	100		
MBR20150CD	150	105	150	0.92	-55 to +175
MBR20200CD	200	140	200		

*1 Repetitive peak reverse voltage

*2 RMS voltage

*3 Continuous reverse voltage

*4 Maximum forward voltage
IF = 10.0A, 25 $^\circ\text{C}$

Rating and characteristic curves (MBR2040CD THRU MBR20200CD)

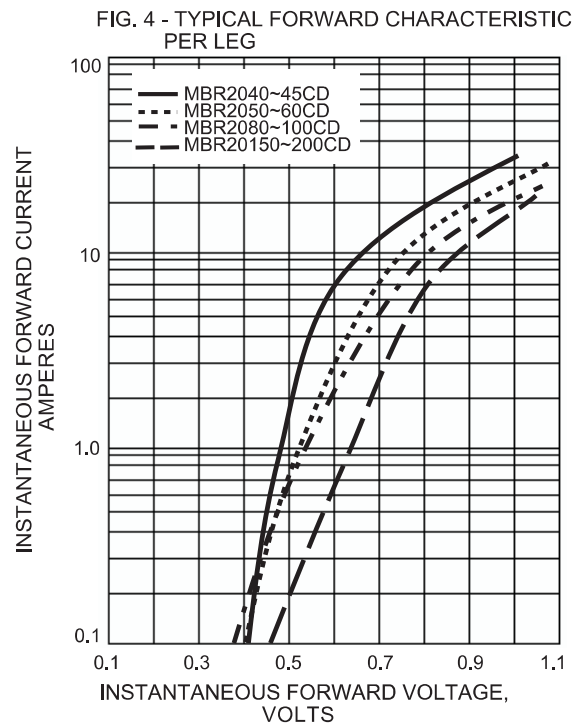
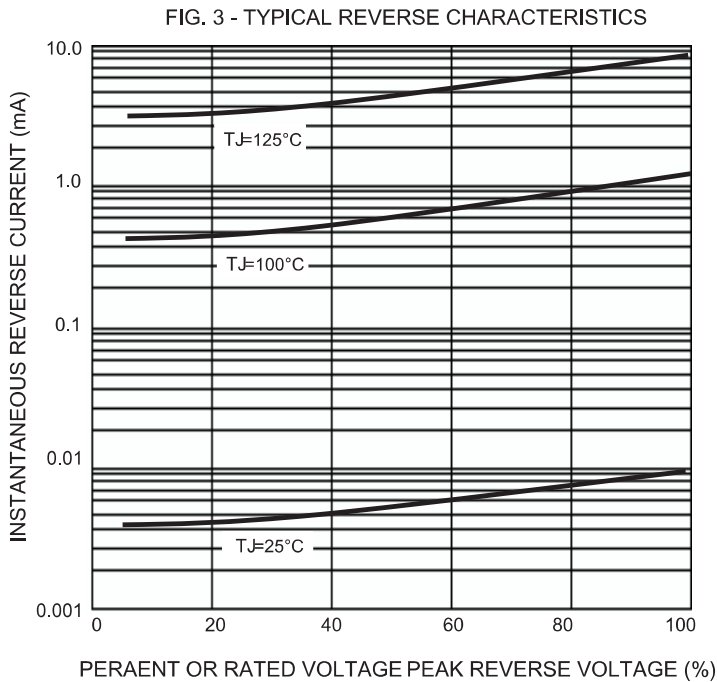
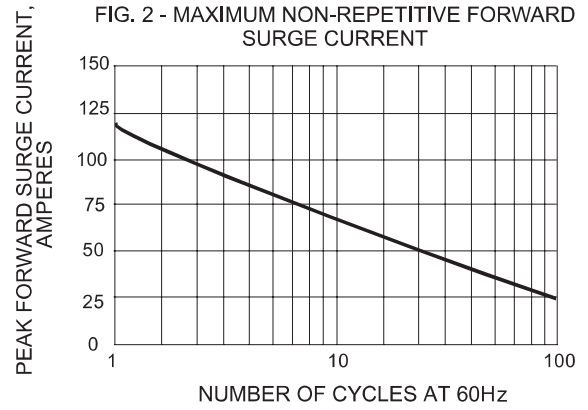
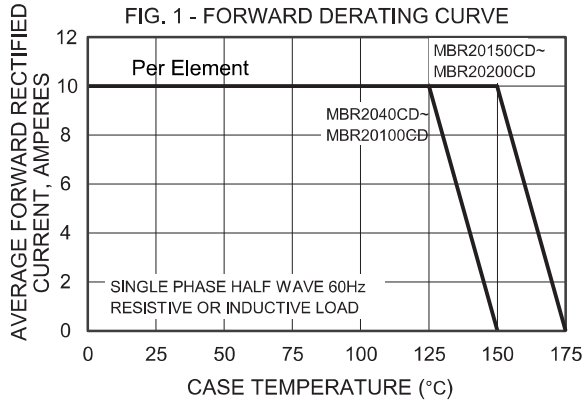

Pinning information

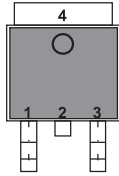
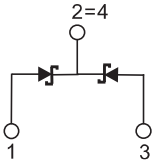
Pin	Simplified outline	Symbol
Pin1 anode Pin2=4 cathode Pin3 anode		

Marking

Type number	Marking code
MBR2040CD	SK2040
MBR2045CD	SK2045
MBR2050CD	SK2050
MBR2060CD	SK2060
MBR2080CD	SK2080
MBR20100CD	SK20100
MBR20150CD	SK20150
MBR20200CD	SK20200

Suggested solder pad layout

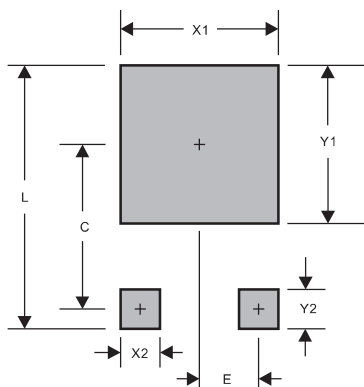

PACKAGE	DPAK
C	0.272(6.90)
E	0.091(2.30)
L	0.457(11.60)
X1	0.276(7.00)
X2	0.059(1.50)
Y1	0.276(7.00)
Y2	0.098(2.50)

Dimensions in inches and (millimeters)