

### Features

- Low power loss, high efficiency.
- High current capability
- High surge capability.
- Guardring for overvoltage protection.
- Low stored charge majority carrier conduction
- Silicon epitaxial planar chip, metal silicon junction.
- Lead-free parts meet environmental standards of MIL-STD-19500 /228
- Suffix "-H" indicates Halogen-free parts, ex. MBR1640FCT-H.

### Mechanical data

- Epoxy : UL94-V0 rated flame retardant
- Case : JEDEC ITO-220AB molded plastic body over passivated chip
- Lead : Axial leads, solderable per MIL-STD-202, Method 208 guranteed
- Polarity: Color band denotes cathode end
- Mounting Position : Any

### Package outline

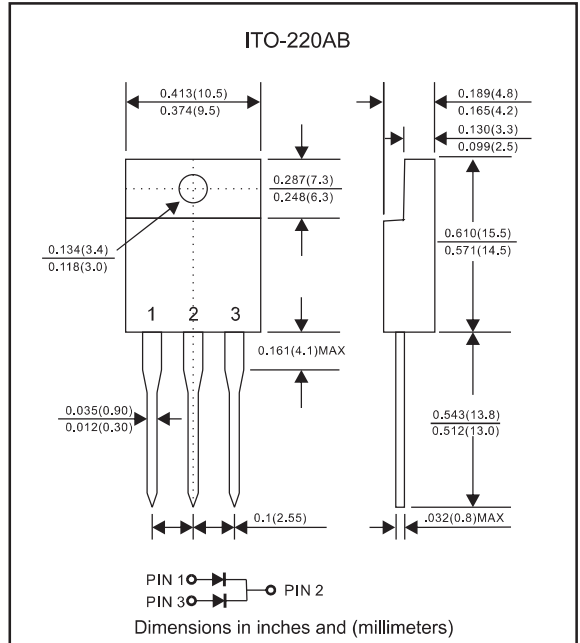

### Maximum ratings and Electrical Characteristics (AT $T_A=25^\circ\text{C}$ unless otherwise noted)

PARAMETER	CONDITIONS	Symbol	MIN.	TYP.	MAX.	UNIT
Forward rectified current	See Fig.1	$I_O$			16.0	A
Forward surge current	8.3ms single half sine-wave (JEDEC methode)	$I_{FSM}$			150	A
Reverse current	$V_R = V_{RRM} T_J = 25^\circ\text{C}$	$I_R$			0.05	mA
	$V_R = V_{RRM} T_J = 125^\circ\text{C}$				10	
Thermal resistance	Junction to case	$R_{\theta JC}$		3.0		$^\circ\text{C}/\text{W}$
Storage temperature		$T_{STG}$	-65		+175	$^\circ\text{C}$

SYMBOLS	$V_{RRM}^{*1}$ (V)	$V_{RMS}^{*2}$ (V)	$V_R^{*3}$ (V)	$V_F^{*4}$ (V)	Operating temperature $T_J$ ( $^\circ\text{C}$ )
MBR1640FCT	40	28	40	0.70	-55 to +150
MBR1645FCT	45	31.5	45		
MBR1650FCT	50	35	50	0.80	
MBR1660FCT	60	42	60		
MBR1680FCT	80	56	80	0.85	-55 to +175
MBR16100FCT	100	70	100		
MBR16150FCT	150	105	150	0.92	
MBR16200FCT	200	140	200		

\*1 Repetitive peak reverse voltage

\*2 RMS voltage

\*3 Continuous reverse voltage

\*4 Maximum forward voltage  
IF = 8.0A

## Rating and characteristic curves (MBR1640FCT THRU MBR16200FCT)

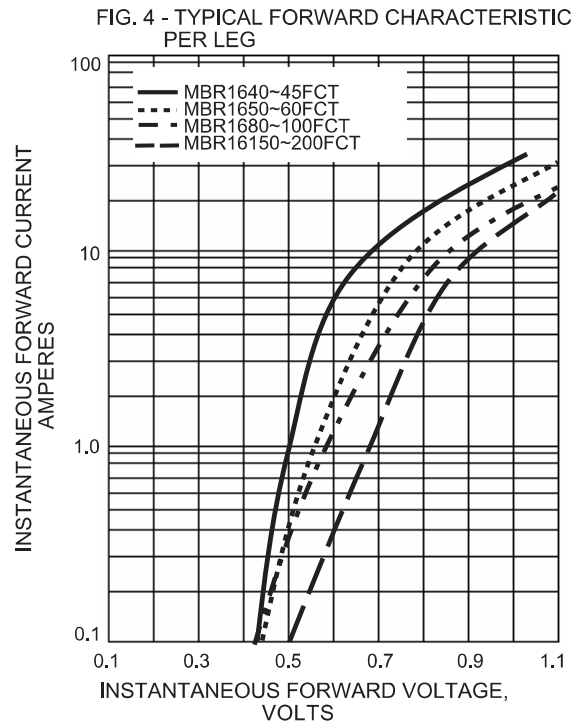
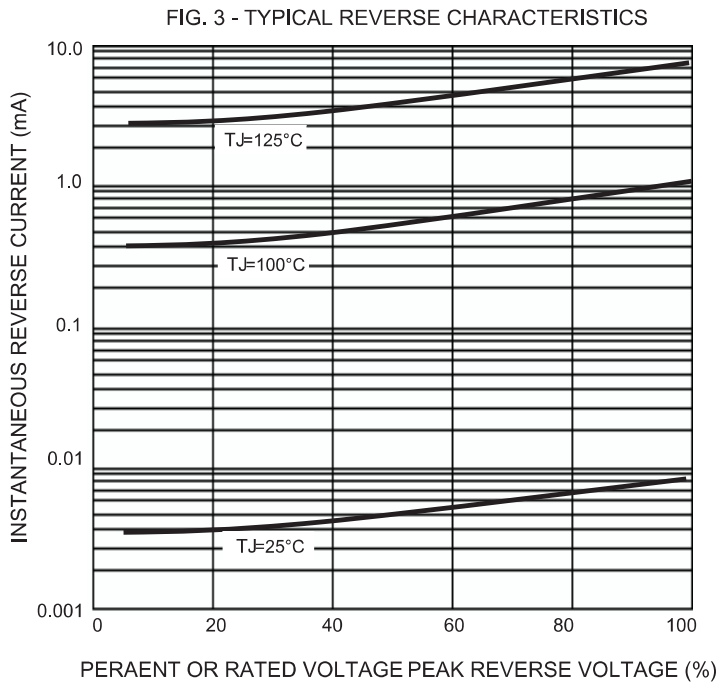
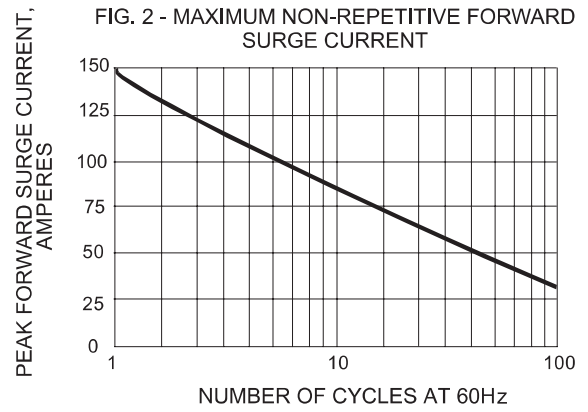
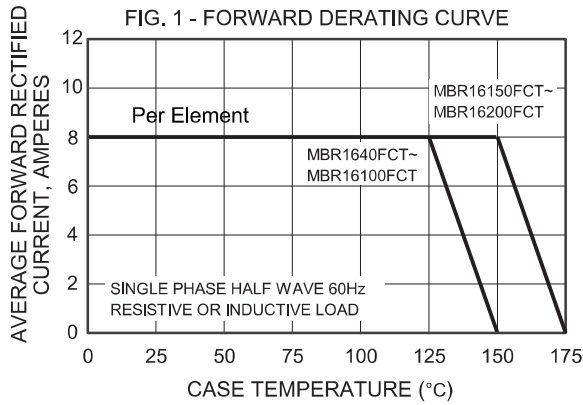

### Pinning information

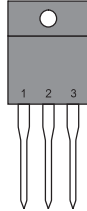
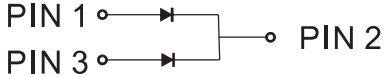
Pin	Simplified outline	Symbol
Pin1 anode Pin2 cathode Pin3 anode		

### Marking

Type number	Marking code
MBR1640FCT	MBR1640FCT
MBR1645FCT	MBR1645FCT
MBR1650FCT	MBR1650FCT
MBR1660FCT	MBR1660FCT
MBR1680FCT	MBR1680FCT
MBR16100FCT	MBR16100FCT
MBR16150FCT	MBR16150FCT
MBR16200FCT	MBR16200FCT