

Features

- Low power loss, high efficiency.
- High current capability
- High surge capability.
- Guardring for overvoltage protection.
- Low stored charge majority carrier conduction
- Silicon epitaxial planar chip, metal silicon junction.
- Lead-free parts meet environmental standards of MIL-STD-19500 /228
- Suffix "-H" indicates Halogen-free part, ex.MBR1040CT-H.

Mechanical data

- Epoxy : UL94-V0 rated flame retardant
- Case : JEDEC TO-220AB molded plastic body over passivated chip
- Lead : Axial leads, solderable per MIL-STD-202, Method 208 guaranteed
- Polarity: As marked
- Mounting Position : Any

Package outline

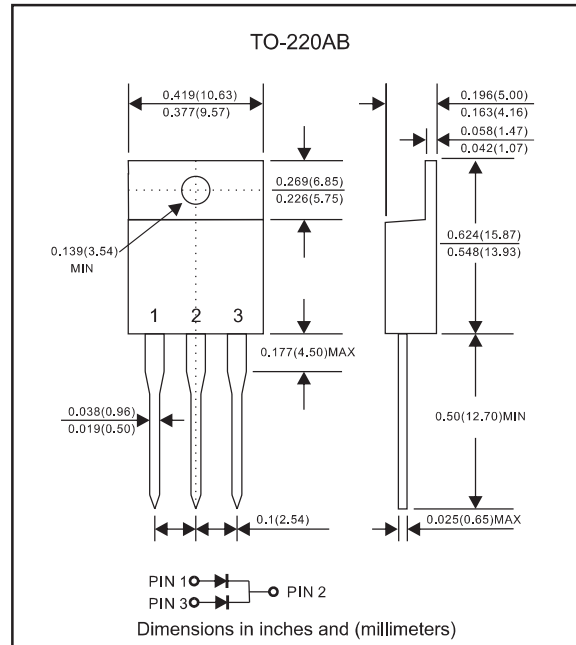

Maximum ratings and Electrical Characteristics (AT $T_A=25^\circ\text{C}$ unless otherwise noted)

PARAMETER	CONDITIONS	Symbol	MIN.	TYP.	MAX.	UNIT
Forward rectified current	See Fig.1	I_o			10.0	A
Forward surge current	8.3ms single half sine-wave (JEDEC methode)	I_{FSM}			120	A
Reverse current	$V_R = V_{RRM}$ $T_J = 25^\circ\text{C}$	I_R			0.05	mA
	$V_R = V_{RRM}$ $T_J = 125^\circ\text{C}$				10	
Thermal resistance	Junction to case	$R_{\theta JC}$		3.0		$^\circ\text{C}/\text{W}$
Storage temperature		T_{STG}	-65		+175	$^\circ\text{C}$

SYMBOLS	V_{RRM}^{*1} (V)	V_{RMS}^{*2} (V)	V_R^{*3} (V)	V_F^{*4} (V)	Operating temperature T_J , ($^\circ\text{C}$)
MBR1040CT	40	28	40	0.70	-55 to +150
MBR1045CT	45	31.5	45		
MBR1050CT	50	35	50	0.80	
MBR1060CT	60	42	60		
MBR1080CT	80	56	80	0.85	
MBR10100CT	100	70	100		
MBR10150CT	150	105	150	0.92	-55 to +175
MBR10200CT	200	140	200		

*1 Repetitive peak reverse voltage

*2 RMS voltage

*3 Continuous reverse voltage

*4 Maximum forward voltage
 $I_F = 5.0\text{A}$, 25°C

Rating and characteristic curves (MBR1040CT THRU MBR10200CT)

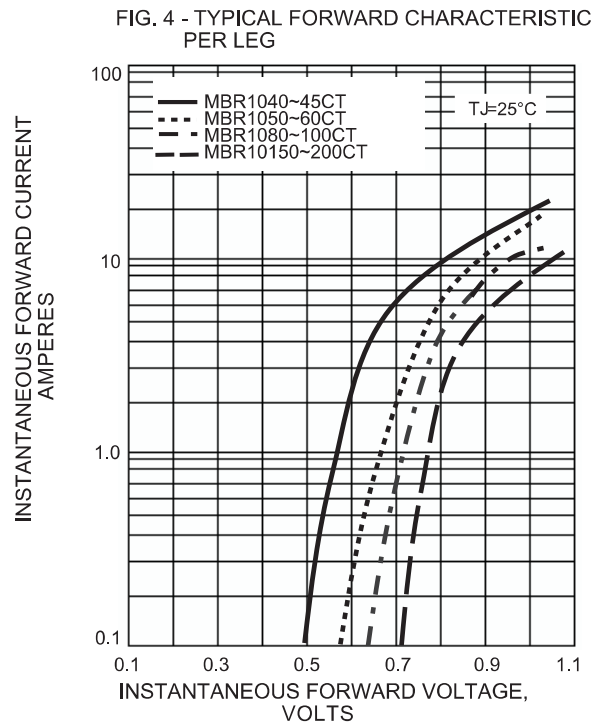
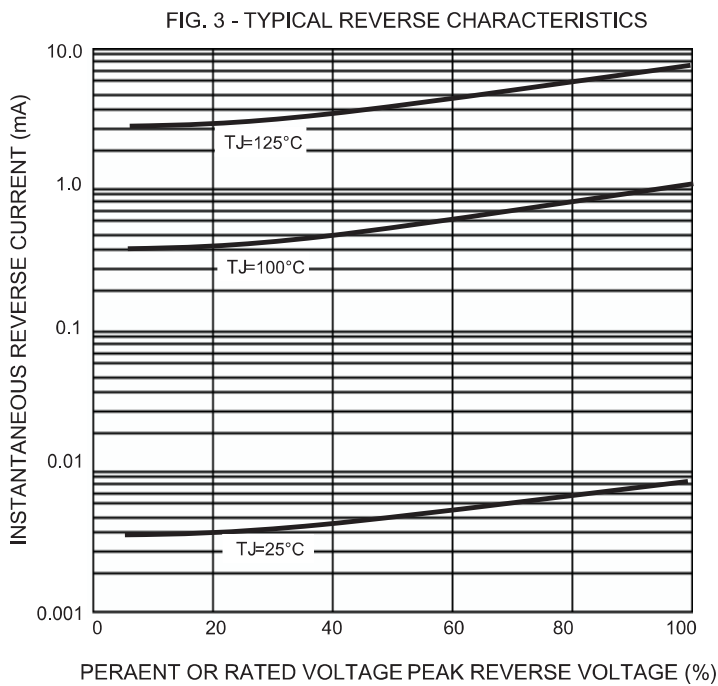
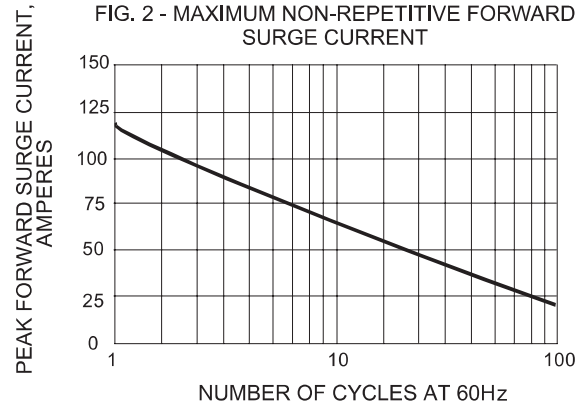
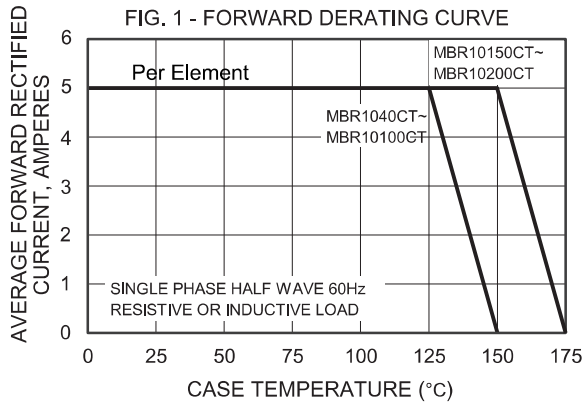

Pinning information

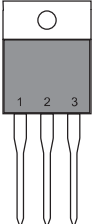
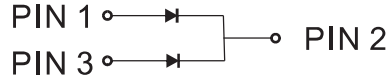
Pin	Simplified outline	Symbol
Pin1 anode Pin2 cathode Pin3 anode		

Marking

Type number	Marking code
MBR1040CT	MBR1040CT
MBR1045CT	MBR1045CT
MBR1050CT	MBR1050CT
MBR1060CT	MBR1060CT
MBR1080CT	MBR1080CT
MBR10100CT	MBR10100CT
MBR10150CT	MBR10150CT
MBR10200CT	MBR10200CT