

Features

- Batch process design, excellent power dissipation offers better reverse leakage current and thermal resistance.
- Low power loss, high efficiency.
- High current capability, low forward voltage drop.
- High surge capability.
- Guardring for overvoltage protection.
- Ultra high-speed switching.
- Silicon epitaxial planar chip, metal silicon junction.
- Lead-free parts meet environmental standards of MIL-STD-19500 /228
- Compliant to Halogen-free

Mechanical data

- Epoxy:UL94-V0 rated flame retardant
- Case : Molded plastic, TO-252AB/DPAK
- Terminals : Solder plated, solderable per MIL-STD-750, Method 2026
- Mounting Position : Any

Package outline

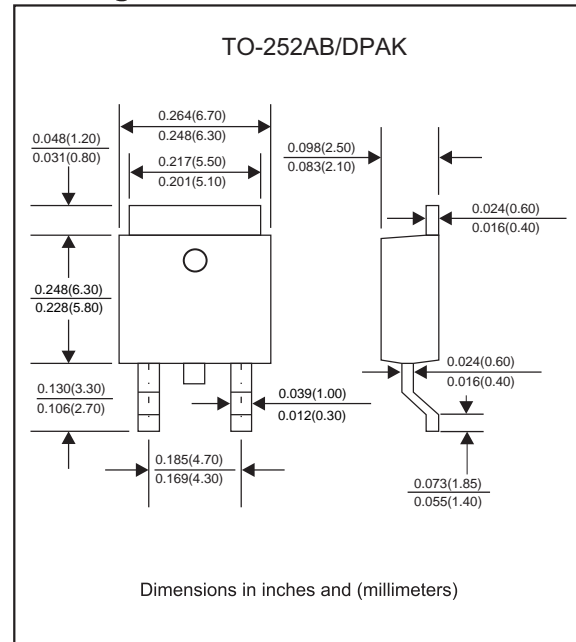

Maximum ratings and Electrical Characteristics (AT $T_A=25^\circ\text{C}$ unless otherwise noted)

PARAMETER	CONDITIONS	Symbol	MIN.	TYP.	MAX.	UNIT
Forward rectified current	See Fig.1	I_o			10.0	A
Forward surge current	8.3ms single half sine-wave (JEDEC methode)	I_{FSM}			150	A
Reverse current	$V_R = V_{RRM} T_A = 25^\circ\text{C}$	I_R			0.3	mA
	$V_R = V_{RRM} T_A = 100^\circ\text{C}$				50	
Diode junction capacitance	f=1MHz and applied 4V DC reverse voltage	C_J		700		pF
Thermal resistance (1)	Junction to Case	$R_{\theta JC}$		6		$^\circ\text{C}/\text{W}$
Storage temperature		T_{STG}	-55		+150	$^\circ\text{C}$

NOTE : (1) Device mounted on additional heatsink, (50mm x 50mm x 23mm Al heatsink).

SYMBOLS	V_{RRM}^{*1} (V)	V_{RMS}^{*2} (V)	V_R^{*3} (V)	V_F^{*4} (V)	Operating temperature T_J , ($^\circ\text{C}$)
MBR1040YD	40	28	40	0.55	-55 to +125
MBR1045YD	45	31.5	45		
MBR1060YD	60	42	60	0.70	-55 to +150
MBR10100YD	100	70	100		
MBR10150YD	150	105	150		
MBR10200YD	200	140	200		

*1 Repetitive peak reverse voltage

*2 RMS voltage

*3 Continuous reverse voltage

*4 Maximum forward voltage
IF = 10.0A, 25 $^\circ\text{C}$

Rating and characteristic curves (MBR1040YD THRU MBR10200YD)

FIG.1-TYPICAL FORWARD CURRENT DERATING CURVE

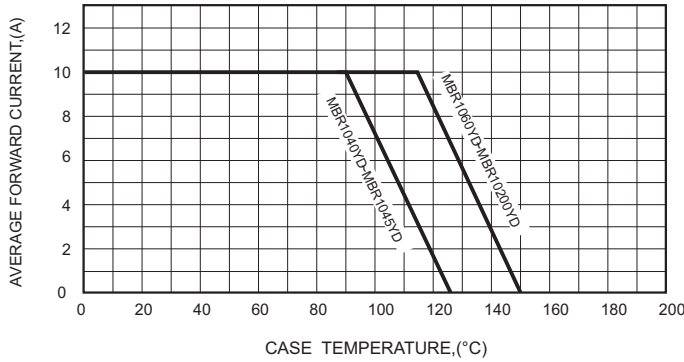

FIG.2-TYPICAL FORWARD CHARACTERISTICS

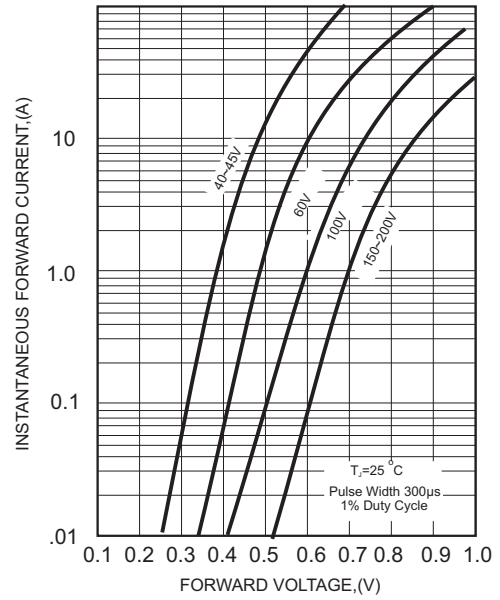

FIG.3-MAXIMUM NON-REPETITIVE FORWARD SURGE CURRENT

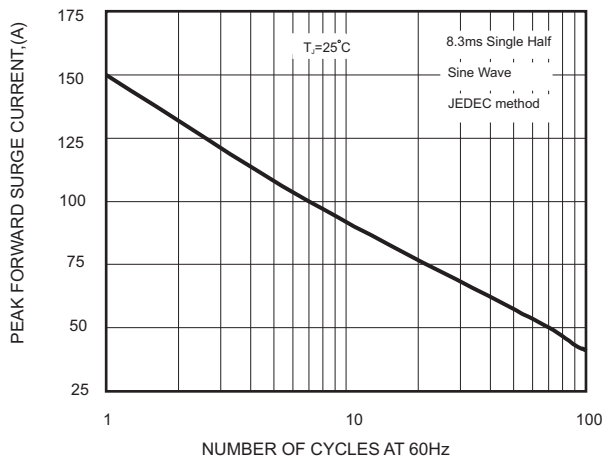

FIG.4- TYPICAL REVERSE CHARACTERISTICS

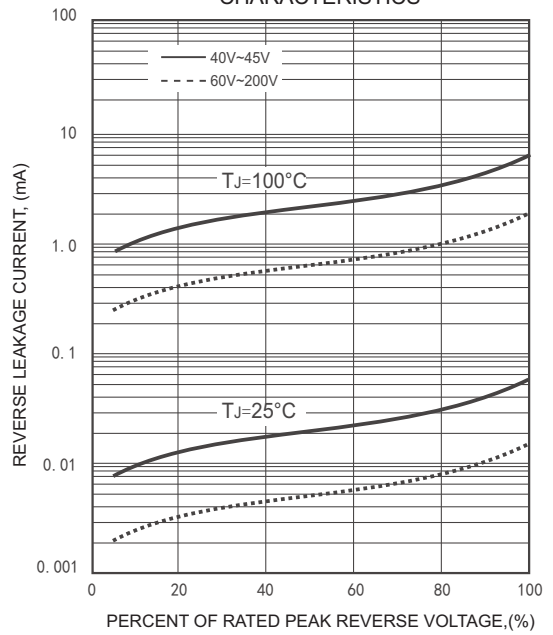
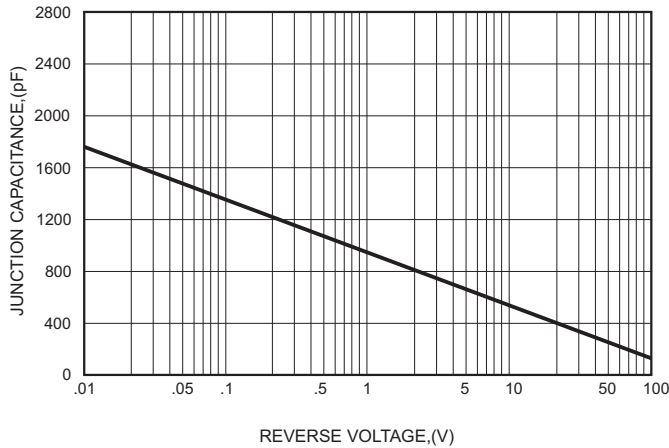
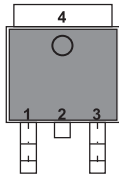
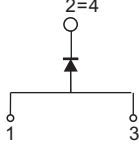

FIG.5-TYPICAL JUNCTION CAPACITANCE



Pinning information

Pin	Simplified outline	Symbol
Pin1 anode Pin2=4 cathode Pin3 anode		

Marking

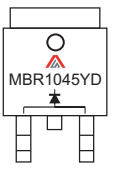
Type number	Marking code	Example
MBR1040YD	MBR1040YD	
MBR1045YD	MBR1045YD	
MBR1060YD	MBR1060YD	
MBR10100YD	MBR10100YD	
MBR10150YD	MBR10150YD	
MBR10200YD	MBR10200YD	

Suggested solder pad layout

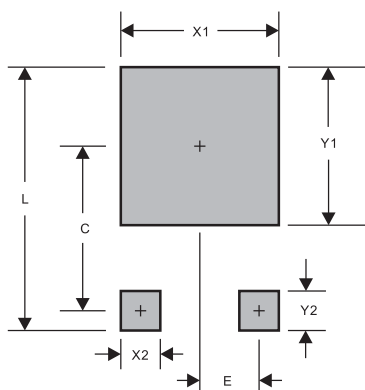

PACKAGE	DPAK
C	0.272(6.90)
E	0.091(2.30)
L	0.457(11.60)
X1	0.276(7.00)
X2	0.059(1.50)
Y1	0.276(7.00)
Y2	0.098(2.50)

Dimensions in inches and (millimeters)