

### Features

- Low current rectification and high speed switching.
- Small surface mount type.
- Up to 200mA current capability.
- Low forward voltage drop.
- Silicon epitaxial planar chip, metal silicon junction.
- Lead-free parts for green partner, exceeds environmental standards of MIL-STD-19500 /228
- High speed ( trr < 5 ns )
- Compliant to Halogen-free

### Mechanical data

- Epoxy:UL94-V0 rated flame retardant
- Case : Molded plastic, SOT-23
- Terminals : Solder plated, solderable per MIL-STD-750, Method 2026
- Mounting Position : Any

### Package outline

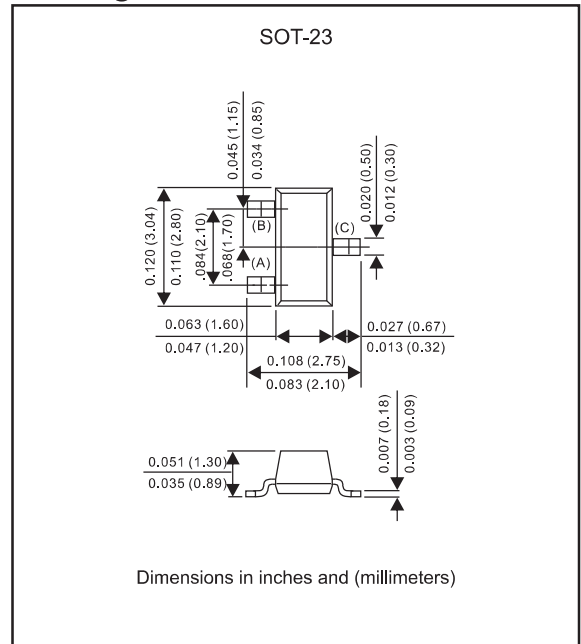

### Maximum ratings and Electrical Characteristics (AT $T_A=25^\circ\text{C}$ unless otherwise noted)

PARAMETER	CONDITIONS	Symbol	MIN.	TYP.	MAX.	UNIT
Repetitive peak reverse voltage		$V_{RRM}$			30	V
Reverse voltage		$V_R$			30	V
Total Device dissipation	FR-5 board, (Note 1) $T_A = 25^\circ\text{C}$ Derate above $25^\circ\text{C}$	$P_D$			200 2.0	mW mW/ $^\circ\text{C}$
Forward surge current	$t=8.3\text{ms}$	$I_{FSM}$			600	mA
Forward current		$I_F$			200	mA
Thermal Resistance	Junction to ambient	$R_{\theta JA}$		500		$^\circ\text{C}/\text{W}$
Operating Junction temperature range		$T_J$	-55		+125	$^\circ\text{C}$
Storage temperature range		$T_{STG}$	-55		+125	$^\circ\text{C}$
Forward voltage	$I_F = 0.1 \text{ mA}$	$V_F$		0.220	0.240	V
	$I_F = 1 \text{ mA}$	$V_F$		0.290	0.320	V
	$I_F = 10 \text{ mA}$	$V_F$		0.350	0.400	V
	$I_F = 30 \text{ mA}$	$V_F$		0.410	0.500	V
	$I_F = 100 \text{ mA}$	$V_F$		0.520	1.000	V
Reverse current	$V_R = 25 \text{ V}$	$I_R$		0.5	2.0	$\mu\text{A}$
Diode capacitance	$V_R = 4 \text{ V}, f = 1\text{MHz}$	$C_J$			10.0	pF
Reverse recovery time	$I_F = I_R = 10 \text{ mAdc}, I_{R(REC)} = 1.0 \text{ mAdc}$	trr			5	ns

Note : 1.FR-5 = 1.0 x 0.75 x 0.062 in

### Rating and characteristic curves for each diode (BAT54 / A / C / S)

FIG.1-TYPICAL FORWARD CHARACTERISTICS

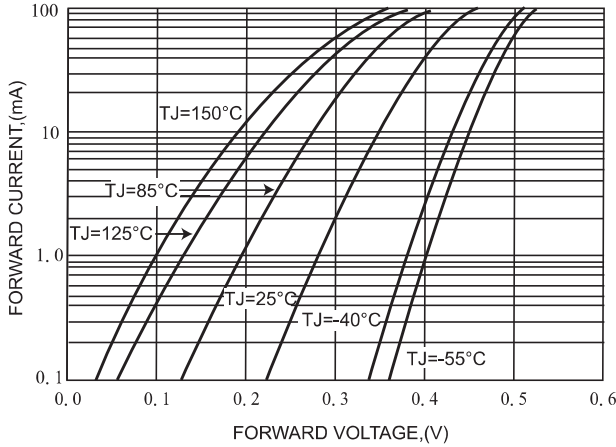

FIG.2 - TYPICAL LEAKAGE CURRENT CHARACTERISTICS

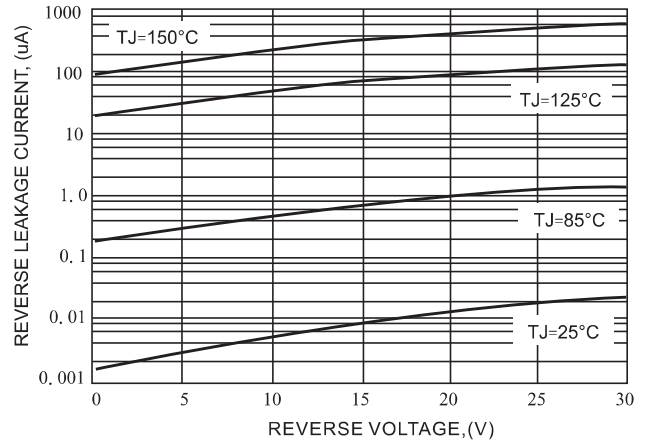
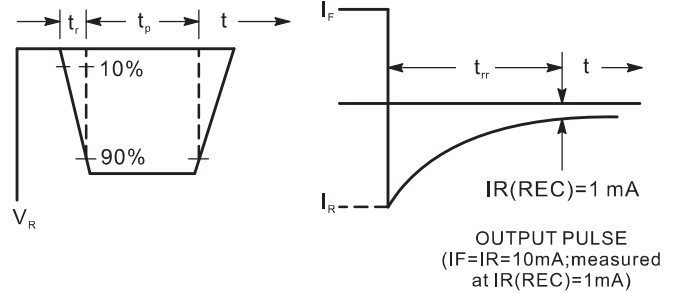
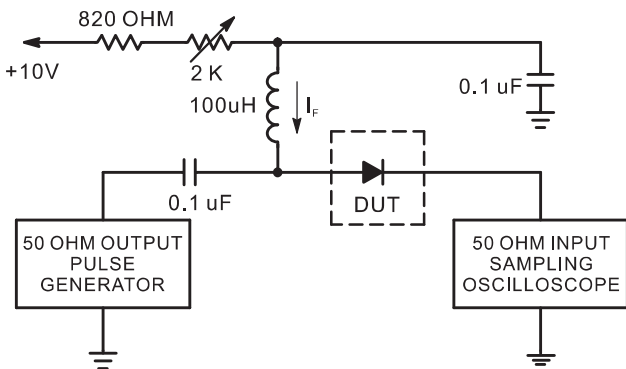
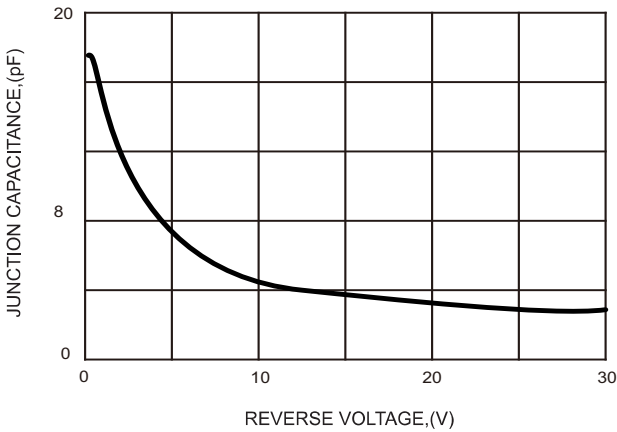

FIG.3-TYPICAL JUNCTION CAPACITANCE



- Notes : 1. A2.0 Kohm variable resistor adjusted for a forward Current (IF) of 10mA.  
 2. Input pulse is adjusted so IR(peak) is equal to 10 mA.  
 3. tp >> trr.

### Recovery Time Equivalent Test Circuit

### Pinning information

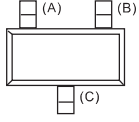
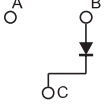
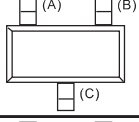
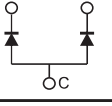
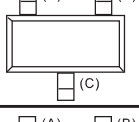
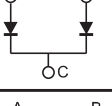
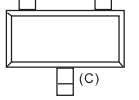
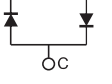
Type number	Marking code	Simplified outline	Symbol
BAT54	JV3, LV3, L4, KL1		
BAT54A	B6, L42, KL2		
BAT54C	5C, KL3, L43		
BAT54S	LD3, L44, KL4		

### Suggested solder pad layout

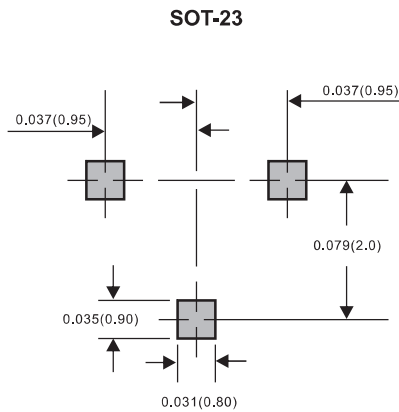

Dimensions in inches and (millimeters)