

Product Summary

$V_{(BR)DSS}$	$R_{DS(on)MAX}$	I_D	$V_{(BR)DSS}$	$R_{DS(on)MAX}$	I_D
30V	32mΩ@10V	4A	-30V	65mΩ@-10V	-3A
	48mΩ@5.5V			100mΩ@-4.5V	

Feature

- Trench power LV MOSFET technology
- High density cell design for low $R_{DS(ON)}$
- High speed switching

Application

- Wireless charger
- Load switch
- Power management

Package

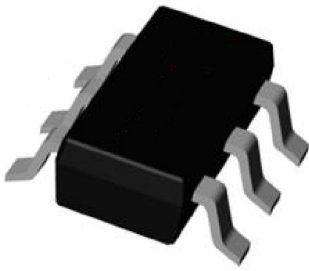

SOT-23-6L

Circuit diagram

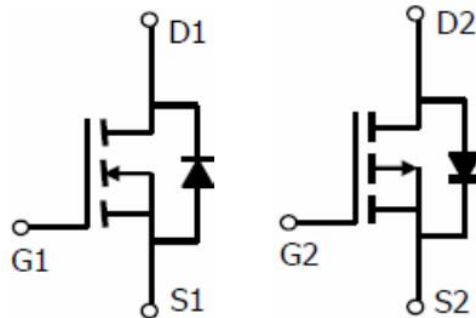

Marking

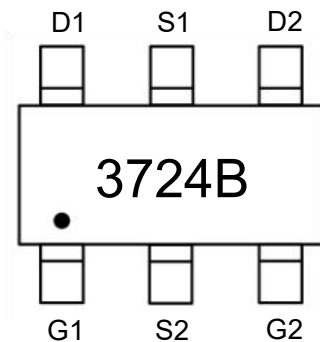

Absolute maximum ratings ($T_A=25^\circ\text{C}$ unless otherwise noted)

Parameter	Symbol	N-Channel	P-Channel	Unit
Drain-Source Voltage	V_{DS}	30	-30	V
Gate-Source Voltage	V_{GS}	± 20	± 20	V
Continuous Drain Current	I_D	4	-3	A
Continuous Drain Current ($T_A=100^\circ\text{C}$)	$I_D(100^\circ\text{C})$	2.5	-1.9	A
Pulsed Drain Current ¹⁾	I_{DM}	30	-20	A
Power Dissipation ²⁾	P_D	1.25	1.25	W
Thermal Resistance Junction-to-Ambient ³⁾	$R_{\theta JA}$	100	100	$^\circ\text{C}/\text{W}$
Operating Junction Temperature	T_J	-55 ~ +150	-55 ~ +150	$^\circ\text{C}$
Storage Temperature	T_{STG}	-55 ~ +150	-55 ~ +150	$^\circ\text{C}$

N-CH Electrical characteristics ($T_J=25^\circ\text{C}$, unless otherwise noted)

Parameter	Symbol	Test Condition	Min.	Typ.	Max.	Unit
Static Characteristics						
Drain-source breakdown voltage	$V_{(BR)DSS}$	$V_{GS} = 0\text{V}, I_D = 250\mu\text{A}$	30			V
Zero gate voltage drain current	I_{DSS}	$V_{DS} = 30\text{V}, V_{GS} = 0\text{V}$			1	μA
Gate-body leakage current	I_{GSS}	$V_{DS} = 0\text{V}, V_{GS} = \pm 20\text{V}$			± 100	nA
Gate threshold voltage	$V_{GS(th)}$	$V_{DS} = V_{GS}, I_D = 250\mu\text{A}$	1	1.5	2.2	V
Drain-source on-resistance	$R_{DS(on)}$	$V_{GS} = 10\text{V}, I_D = 4\text{A}$		24	32	m Ω
		$V_{GS} = 4.5\text{V}, I_D = 2\text{A}$		37	48	
Dynamic characteristics⁴⁾						
Input Capacitance	C_{iss}	$V_{DS} = 15\text{V}, V_{GS} = 0\text{V}, f = 1\text{MHz}$		235		pF
Output Capacitance	C_{oss}			43		
Reverse Transfer Capacitance	C_{rss}			35		
Total Gate Charge	Q_g	$V_{DS} = 15\text{V}, V_{GS} = 10\text{V}, I_D = 4\text{A}$		6		nC
Gate-Source Charge	Q_{gs}			1.25		
Gate-Drain Charge	Q_{gd}			1.3		
Turn-on delay time	$t_{d(on)}$	$V_{DS} = 15\text{V}, V_{GS} = 10\text{V}, I_D = 4\text{A}$ $R_G = 3\Omega$		4		nS
Turn-on rise time	t_r			23		
Turn-off delay time	$t_{d(off)}$			7		
Turn-off fall time	t_f			19		
Source-Drain Diode characteristics						
Diode Forward Current	I_S				4	A
Diode Forward voltage	V_{SD}	$V_{GS} = 0\text{V}, I_S = 4\text{A}$			1.2	V
Reverse Recovery Time	T_{rr}	$I_F = 4\text{A}, di/dt = -100\text{A}/\mu\text{s}$		17		nS
Reverse Recovery Charge	Q_{rr}			1.7		nC

P-CH Electrical characteristics (T_J=25 °C, unless otherwise noted)

Parameter	Symbol	Test Condition	Min.	Typ.	Max.	Unit
Static Characteristics						
Drain-source breakdown voltage	V _{(BR)DSS}	V _{GS} =0V, I _D =-250μA	-30			V
Zero gate voltage drain current	I _{DSS}	V _{DS} =-30V, V _{GS} =0V			-1	μA
Gate-body leakage current	I _{GSS}	V _{DS} =0V, V _{GS} =±20V			±100	nA
Gate threshold voltage	V _{GS(th)}	V _{DS} =V _{GS} , I _D =-250μA	-1	-1.5	-2.4	V
Drain-source on-resistance	R _{DS(on)}	V _{GS} =-10V, I _D =-3A		48	65	mΩ
		V _{GS} =-4.5V, I _D =-2A		75	100	
Dynamic characteristics⁴⁾						
Input Capacitance	C _{iss}	V _{DS} =-15V, V _{GS} =0V, f =1MHz		260		pF
Output Capacitance	C _{oss}			50		
Reverse Transfer Capacitance	C _{rss}			40		
Total Gate Charge	Q _g	V _{DS} =-15V, V _{GS} =-10V, I _D =-3A		7		nC
Gate-Source Charge	Q _{gs}			2		
Gate-Drain Charge	Q _{gd}			1		
Turn-on delay time	t _{d(on)}	V _{DS} =-15V, V _{GS} =-10V I _D =-3A, R _G =3Ω		5		nS
Turn-on rise time	t _r			23		
Turn-off delay time	t _{d(off)}			21		
Turn-off fall time	t _f			30		
Source-Drain Diode characteristics						
Diode Forward Current	I _S				-3	A
Diode Forward voltage	V _{SD}	V _{GS} =0V, I _S =-3A			-1.2	V
Reverse Recovery Time	T _{rr}	I _F =-3A, di/dt =-100A/μs		12		nS
Reverse Recovery Charge	Q _{rr}				4	

Notes:

- 1) Repetitive rating; pulse width limited by max. junction temperature.
- 2) Pd is based on max. junction temperature, using junction-case thermal resistance.
- 3) The value of R_{θJA} is measured with the device mounted on 1 in² FR-4 board with 2oz. Copper, in the still air environment with T_A =25°C. The maximum allowed junction temperature of 150°C. The value in any given application depends on the user's specific board design.
- 4) Guaranteed by design, not subject to production testing.

N-Channel Typical Characteristics

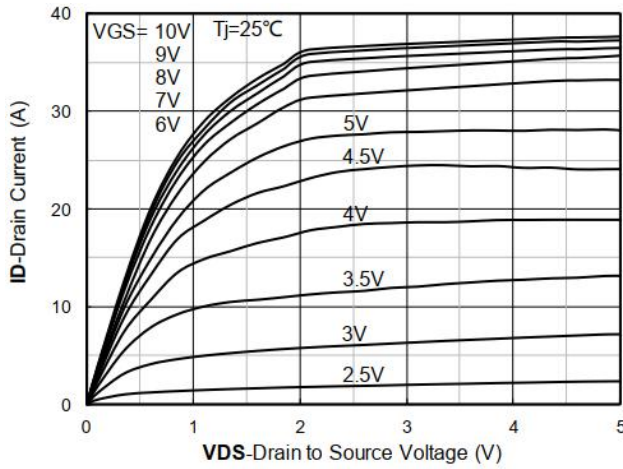

Figure 1. Output Characteristics

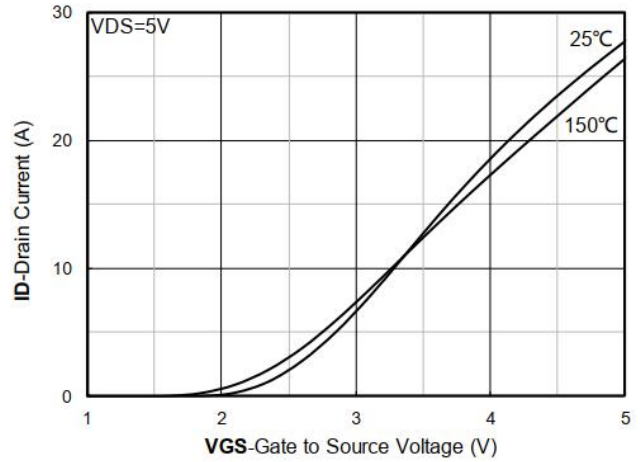

Figure 2. Transfer Characteristics

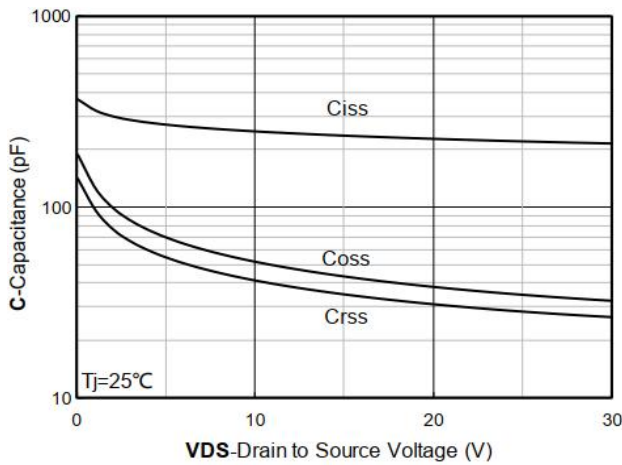

Figure 3. Capacitance Characteristics

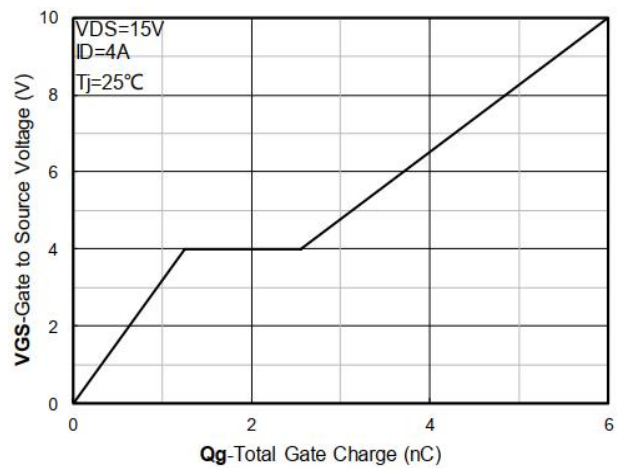

Figure 4. Gate Charge

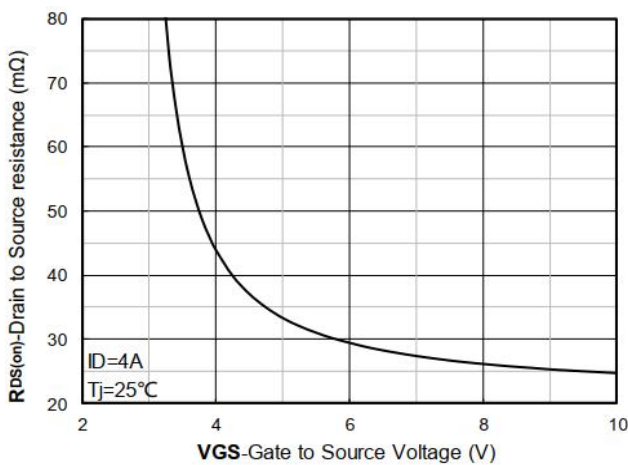

Figure 5. On-Resistance vs Gate to Source Voltage

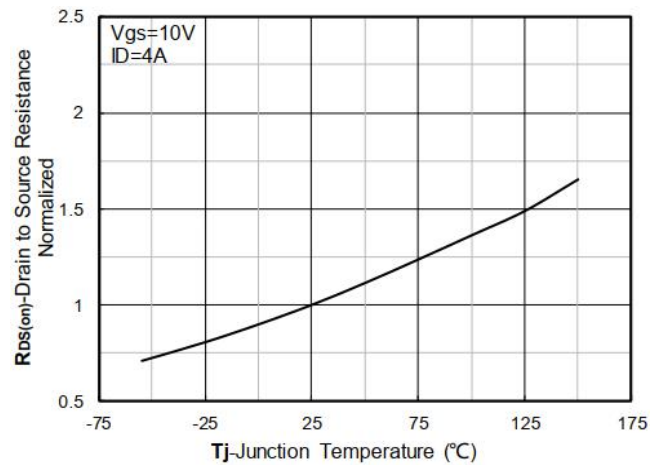

Figure 6. Normalized On-Resistance

N-Channel Typical Characteristics

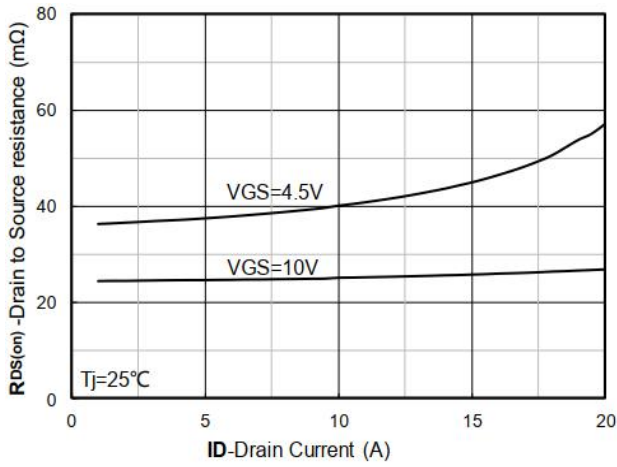

Figure 7. $R_{DS(on)}$ VS Drain Current

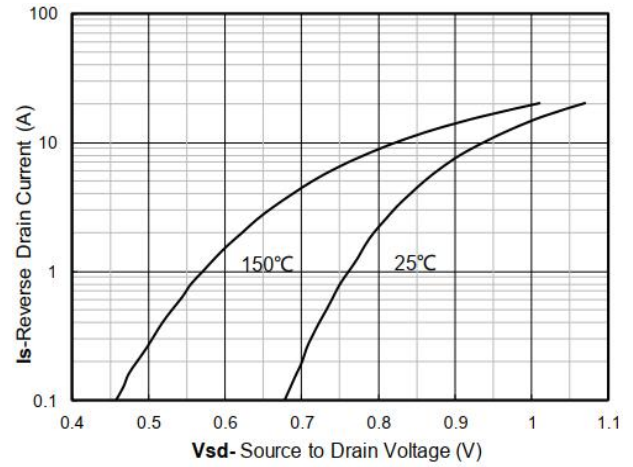

Figure 8. Forward characteristics of reverse diode

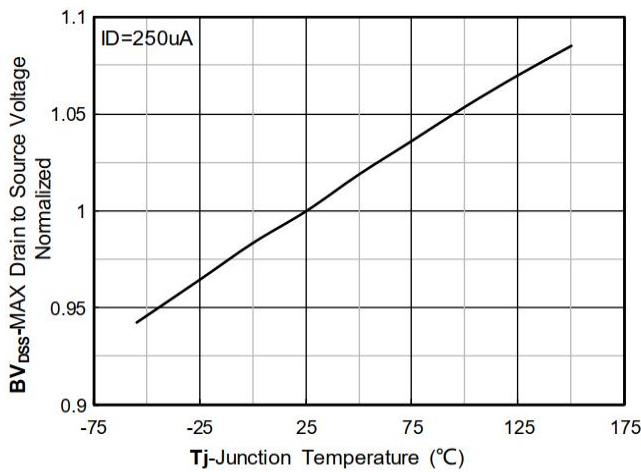

Figure 9. Normalized breakdown voltage

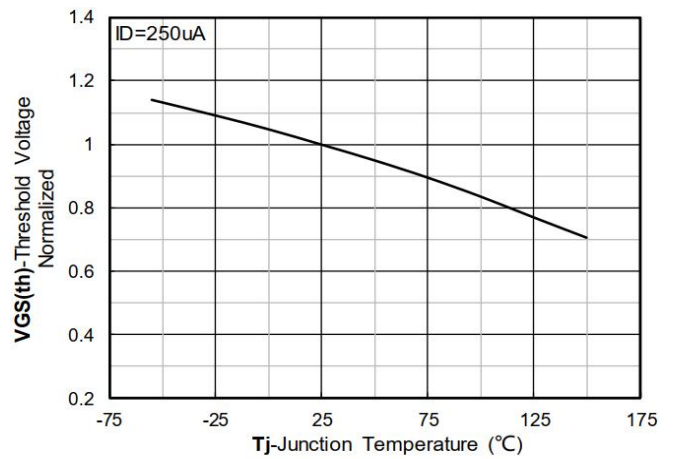

Figure 10. Normalized Threshold voltage

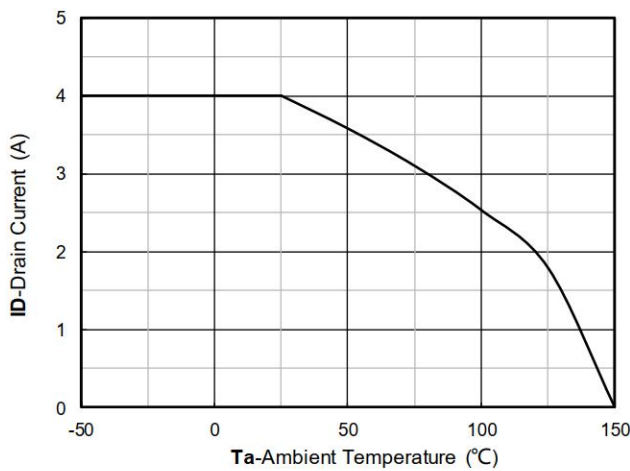

Figure 11. Current dissipation

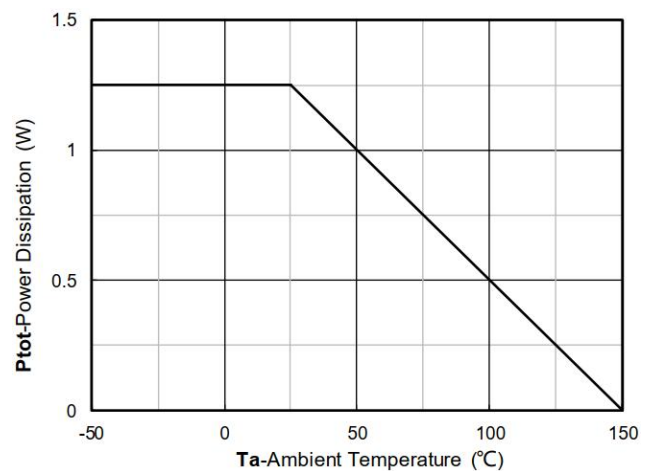

Figure 12. Power dissipation

N-Channel Typical Characteristics

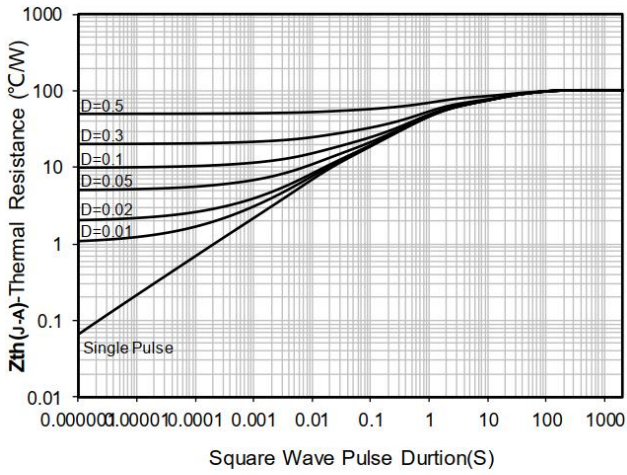

Figure 13. Maximum Transient Thermal Impedance

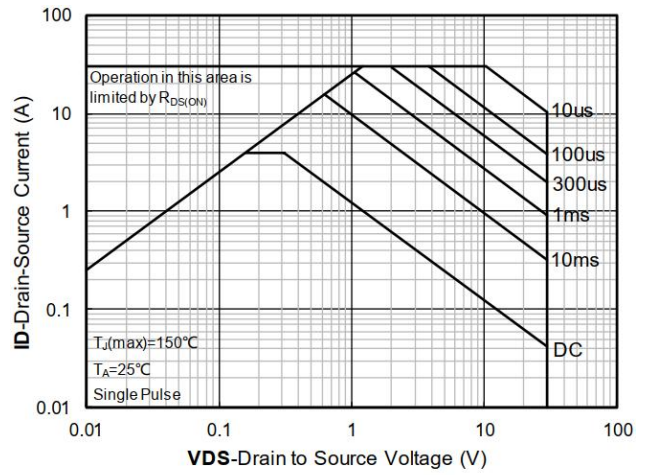

Figure 14. Safe Operation Area

P-Channel Typical Characteristics

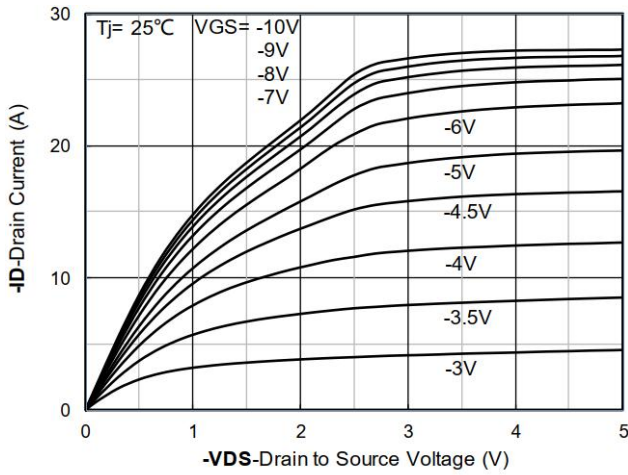

Figure 1. Output Characteristics

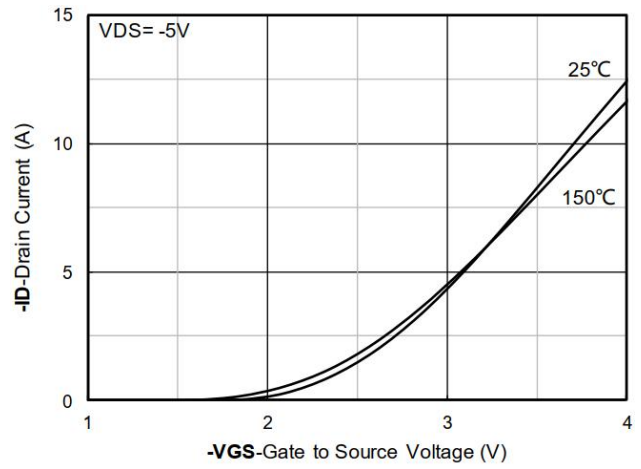

Figure 2. Transfer Characteristics

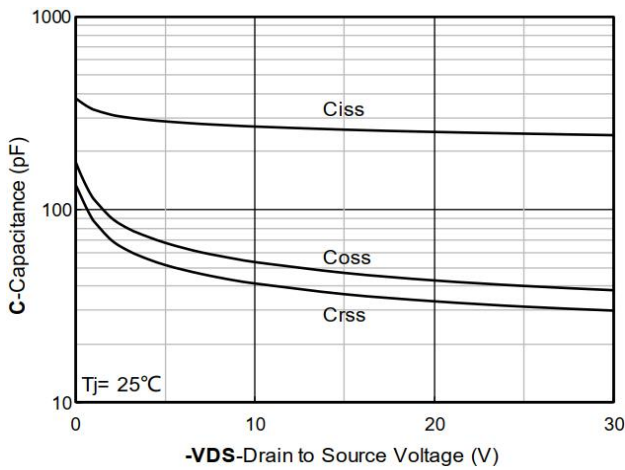

Figure 3. Capacitance Characteristics

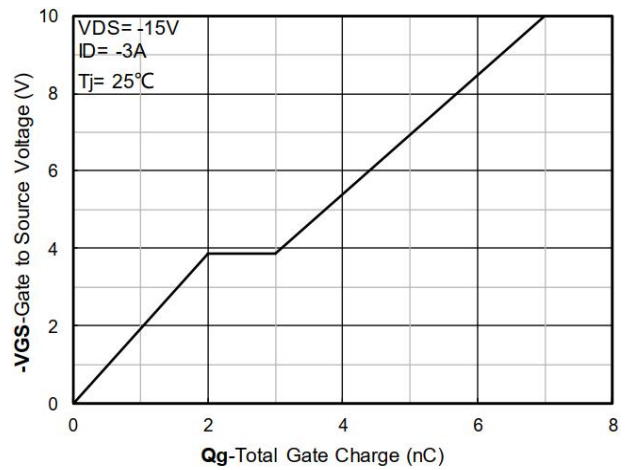

Figure 4. Gate Charge

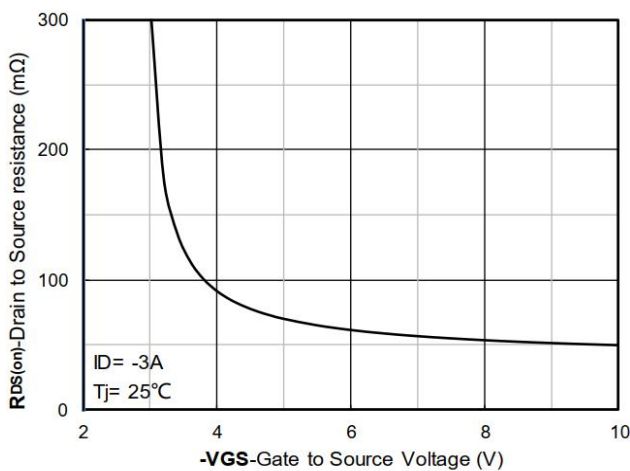

Figure 5. On-Resistance vs Gate to Source Voltage

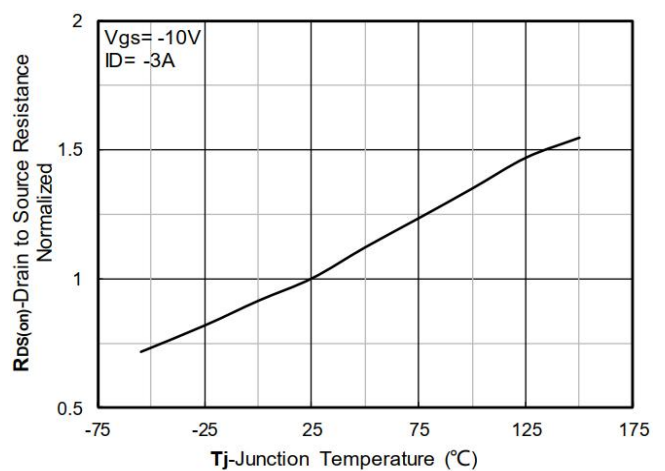

Figure 6. Normalized On-Resistance

P-Channel Typical Characteristics

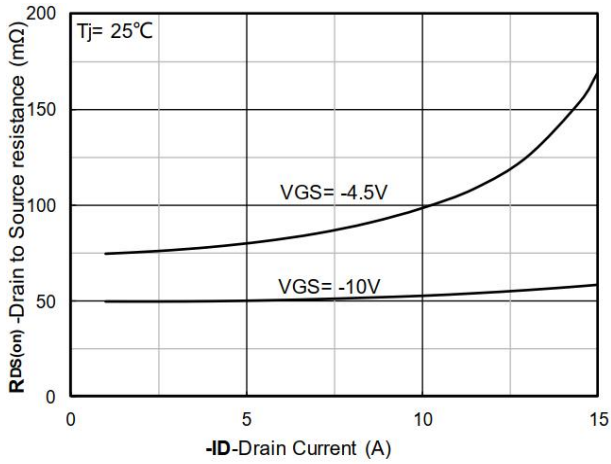

Figure 7. RDS(on) VS Drain Current

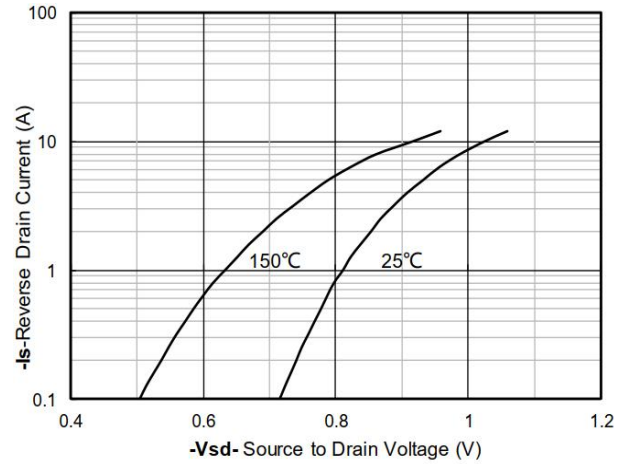

Figure 8. Forward characteristics of reverse diode

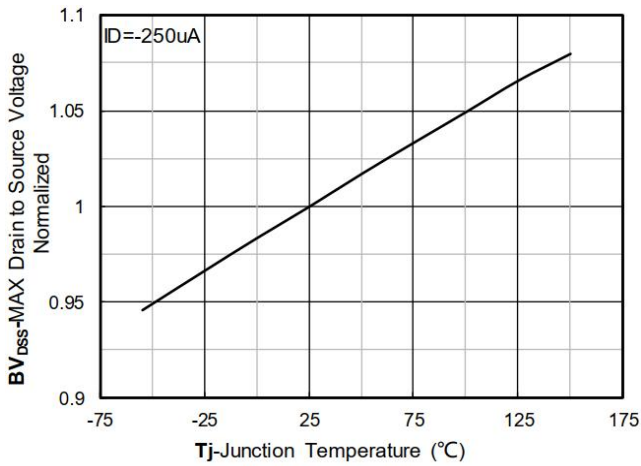

Figure 9. Normalized breakdown voltage

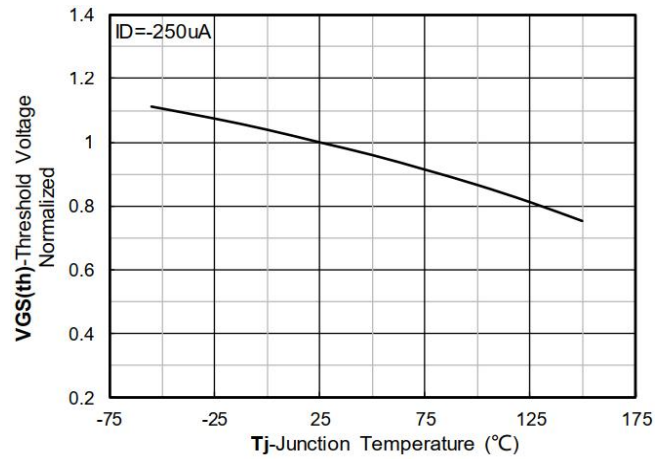

Figure 10. Normalized Threshold voltage

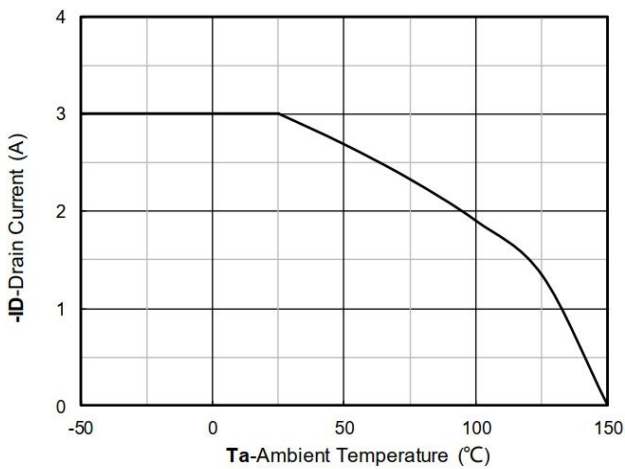

Figure 11. Current dissipation

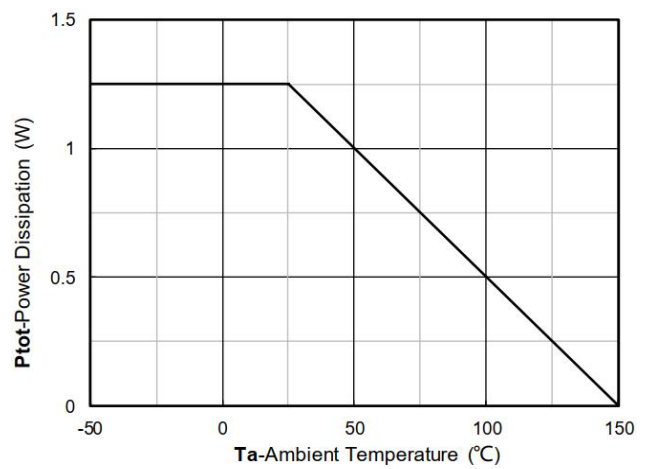

Figure 12. Power dissipation

P-Channel Typical Characteristics

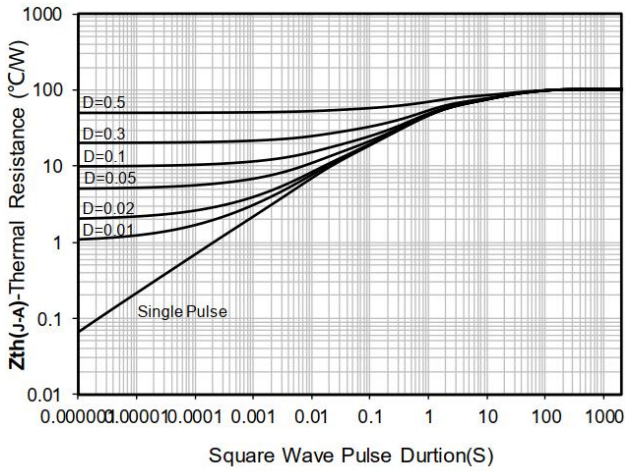

Figure 13. Maximum Transient Thermal Impedance

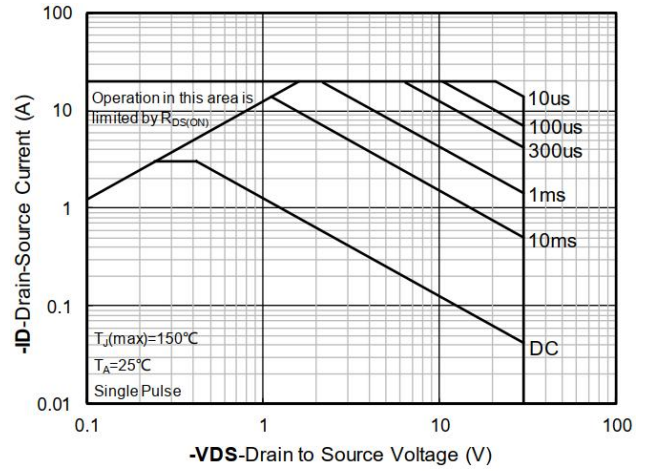
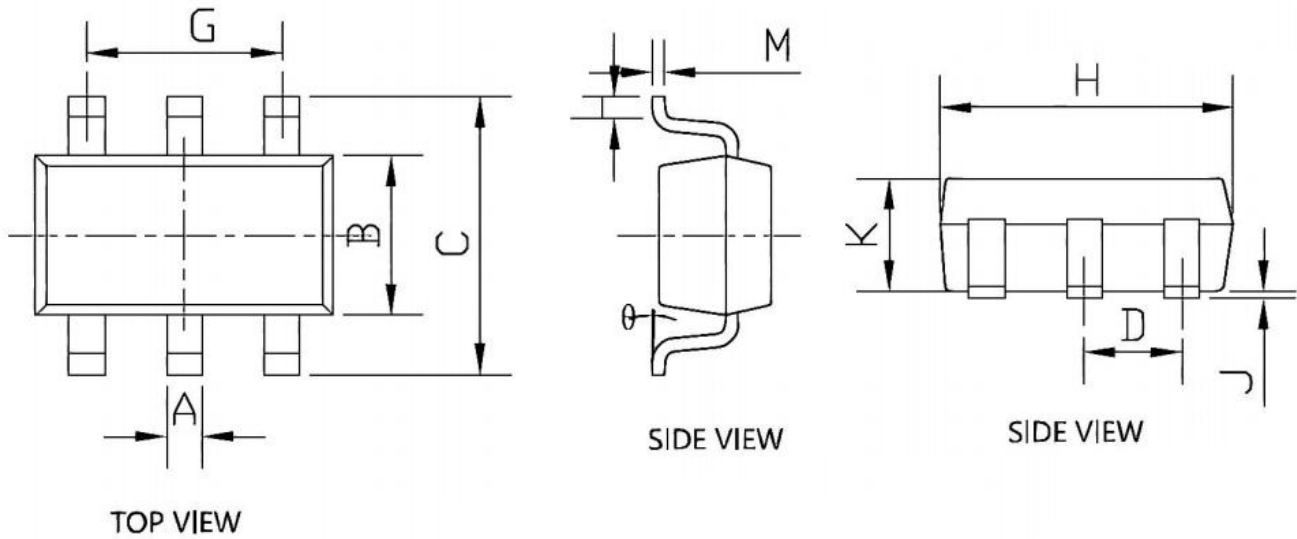

Figure 14. Safe Operation Area

SOT-23-6L Package Information



Symbol	Dimensions In Millimeters		Dimensions In Inches	
	Min.	Max.	Min.	Max.
A	0.300	0.500	0.012	0.020
B	1.500	1.700	0.059	0.067
C	2.650	2.950	0.104	0.116
D	0.950 BSC.		0.037 BSC.	
G	1.900 BSC.		0.075 BSC.	
H	2.820	3.020	0.111	0.119
J	0.000	0.100	0.000	0.004
K	1.050	1.150	0.041	0.045
L	0.300	0.600	0.012	0.024
M	0.100	0.200	0.004	0.008
θ	0°	8°	0°	8°