

Product Summary

$V_{(BR)DSS}$	$R_{DS(on)TYP}$	$I_D@25^{\circ}C$
650V	45mΩ@20V	55A

Feature

- Wide bandgap SiC MOSFET technology
- Low On-Resistance with High Blocking Voltage
- Low Capacitances with High-Speed switching
- Low reverse recovery(Qrr)

Application

- Switch Mode Power Supplies
- Renewable Energy
- Motor Drives
- High Voltage DC/DC Converters

Package



TO-247-4

Marking

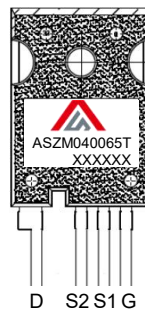

Circuit diagram

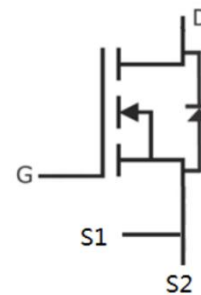

Absolute maximum ratings ($T_C=25^{\circ}C$ unless otherwise noted)

Parameter	Symbol	Test Condition	Value	Unit
Drain-Source Voltage	V_{DS}	$V_{GS} = 0V, I_D = 100\mu A$	650	V
Gate-Source Voltage	V_{GSmax}	AC ($f > 1 \text{ Hz}$)	-10/+25	V
Gate-Source Voltage	V_{GSOP}	Static	-4/+20	V
Continuous Drain Current	I_D	$V_{GS} = 20V, T_C=25^{\circ}C$	55	A
	I_D	$V_{GS} = 20V, T_C=100^{\circ}C$	39	A
Pulsed Drain Current	$I_{D,pulse}$	Pulse with t_p limited by T_{jmax} at 1 ms	95	A
		Pulse with t_p limited by T_{jmax} at 100 μs	231	A
Power Dissipation	P_D	$T_C=25^{\circ}C$	208	W
Thermal Resistance (Typ)	$R_{\theta JC}$	Junction-to-Case	0.72	$^{\circ}C/W$
Junction Temperature	T_J		-55~ +175	$^{\circ}C$
Storage Temperature	T_{STG}		-55~ +175	$^{\circ}C$

Electrical characteristics (T_j=25°C, unless otherwise noted)

Parameter	Symbol	Test Condition	Min.	Typ.	Max.	Unit
Static Characteristics						
Drain-source breakdown voltage	V _{(BR)DSS}	V _{GS} = 0V, I _D = 100μA	650			V
Zero gate voltage drain current	I _{DSS}	V _{DS} = 650V, V _{GS} = 0V		1	50	μA
Gate-Source leakage current	I _{GSS}	V _{GS} = 20V, V _{DS} = 0V			250	nA
Gate threshold voltage	V _{GS(th)}	V _{DS} = V _{GS} , I _D = 5mA		2.7		V
		V _{DS} = V _{GS} , I _D = 5mA, T _j = 175°C		1.8		
Drain-source on-resistance	R _{DS(on)}	V _{GS} = 20V, I _D = 20A		45	58	mΩ
		V _{GS} = 20V, I _D = 20A, T _j = 175°C		60		
Transconductance	g _{fs}	V _{GS} = 20V, I _D = 20A		18		S
		V _{GS} = 20V, I _D = 20A, T _j = 175°C		11		
Dynamic characteristics						
Input Capacitance	C _{iss}	V _{DS} = 600V, V _{GS} = 0V, f = 1MHz V _{AC} = 25mV		1410		pF
Output Capacitance	C _{oss}			119		
Reverse Transfer Capacitance	C _{rss}			4		
Total Gate Charge	Q _g	V _{DS} = 400V, I _D = 20A V _{GS} = -4V/20V		66.2		nC
Gate-Source Charge	Q _{gs}			16.4		
Gate-Drain Charge	Q _{gd}			16.5		
Turn-on delay time	t _{d(on)}	V _{DS} = 400V, V _{GS} = -4/+20V, I _D = 20A, R _{G(int)} = 5Ω, L = 276μH		10.3		nS
Turn-on rise time	t _r			8.9		
Turn-off delay time	t _{d(off)}			16.3		
Turn-off fall time	t _f			8		μJ
Turn-On Energy	E _{on}			47.9		
Turn-Off Energy	E _{off}			45.8		
Total switching energy	E _{tot}			93.7		
Source-Drain Diode characteristics						
Diode Forward Current	I _S	V _{GS} = -4V, T _C = 25°C		46		A
Diode Forward voltage	V _{SD}	V _{GS} = -4V, I _{SD} = 8.8A		3.7		V
		V _{GS} = -4V, I _{SD} = 8.8A, T _J = 175°C		3.1		V
Reverse Recovery Time	t _{rr}	V _{GS} = -4V, I _{SD} = 20A, V _R = 400V dif/dt = 2500 A/μs		31.7		nS
Reverse Recovery Charge	Q _{rr}			188.5		nC
Peak Reverse Recovery Current	I _{rrm}				11.6	

Typical Characteristics

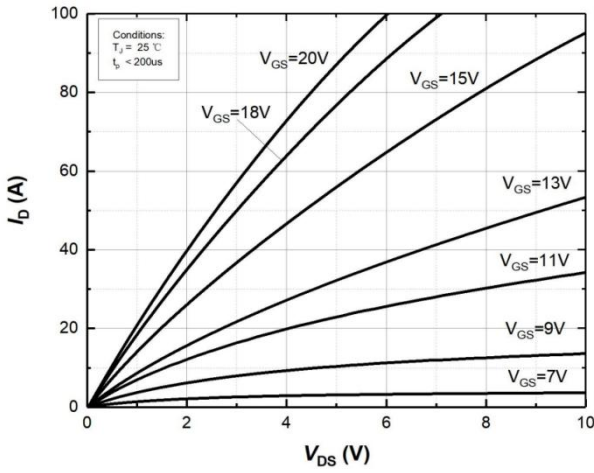

Figure 1. Output characteristics at $T_j=25^\circ\text{C}$

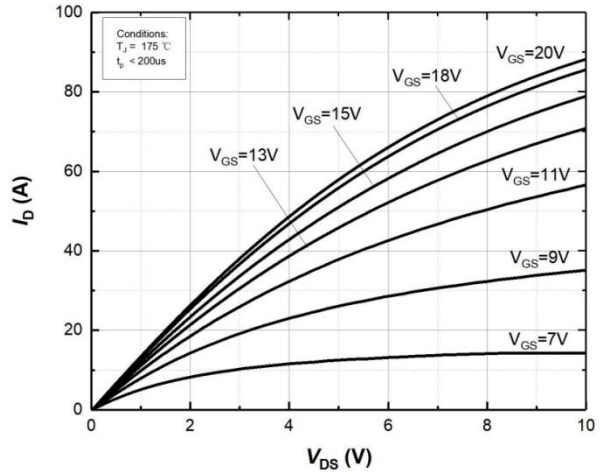

Figure 2. Output characteristics at $T_j=175^\circ\text{C}$

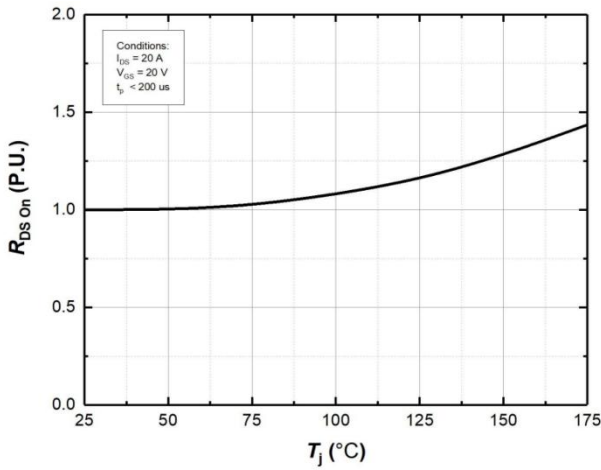

Figure 3. Normalized On-Resistance vs. Temperature

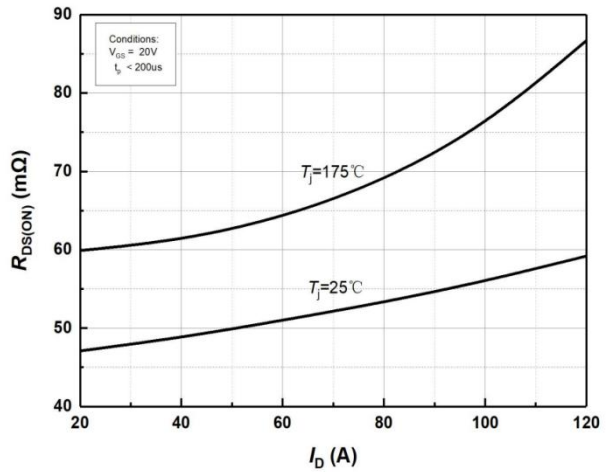

Figure 4. On-Resistance vs. Drain current for Various Temperature

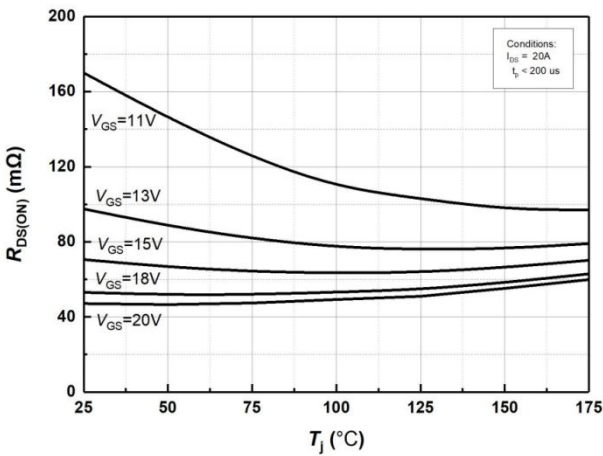

Figure 5. On-Resistance vs. Temperature for Various Gate Voltage

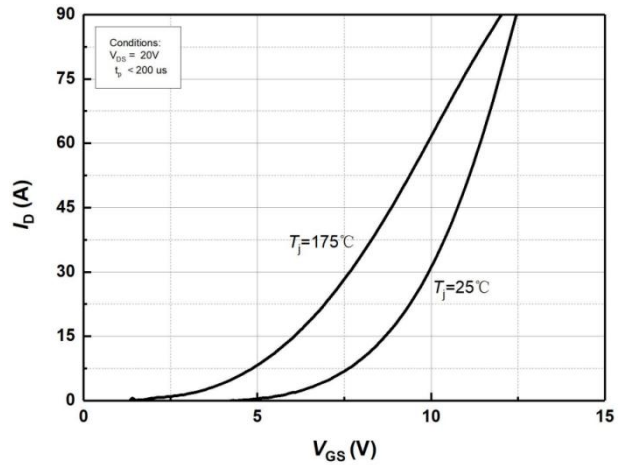

Figure 6. Transfer Characteristics for Various Junction Temperatures

Typical Characteristics

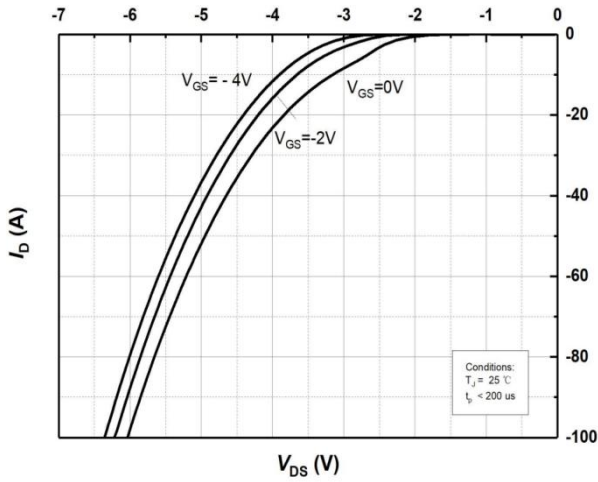

Figure 7. Body Diode Characteristics at $T_j = 25^\circ\text{C}$

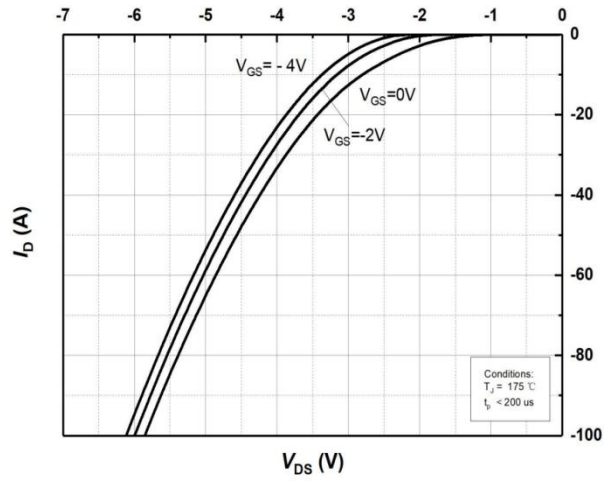

Figure 8. Body Diode Characteristics at $T_j = 175^\circ\text{C}$

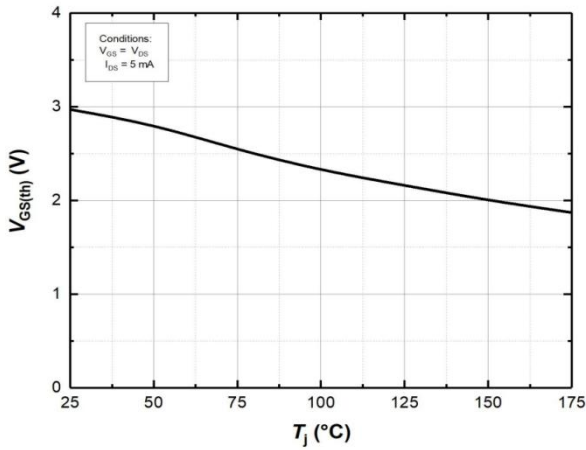

Figure 9. Threshold Voltage vs. Temperature

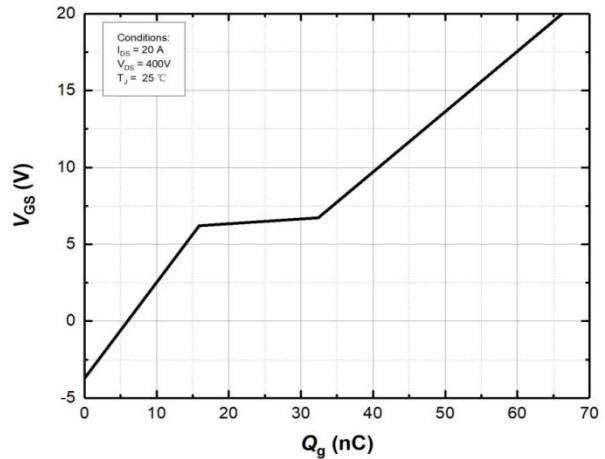

Figure 10. Gate Charge Characteristics

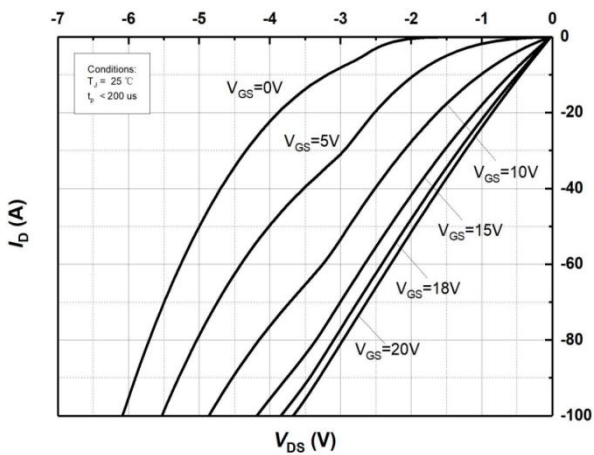

Figure 11. 3rd Quadrant Characteristic at $T_j = 25^\circ\text{C}$

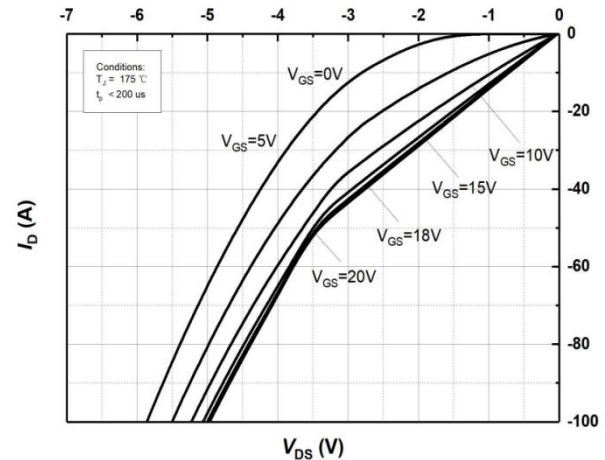

Figure 12. 3rd Quadrant Characteristic at $T_j = 175^\circ\text{C}$

Typical Characteristics

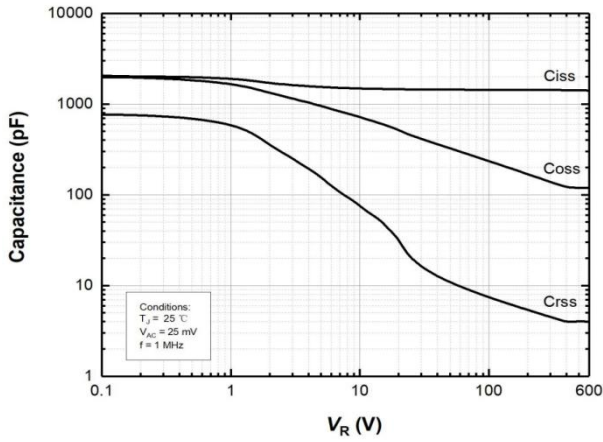

Figure 13. Capacitances vs. Drain-Source Voltage (0 – 600V)

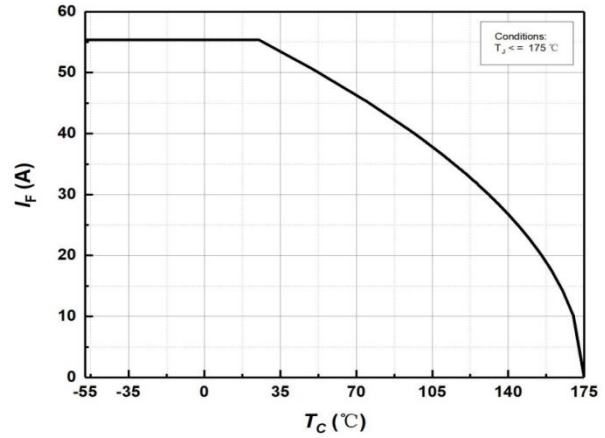

Figure 14. Continuous Drain Current Derating vs Case Temperature

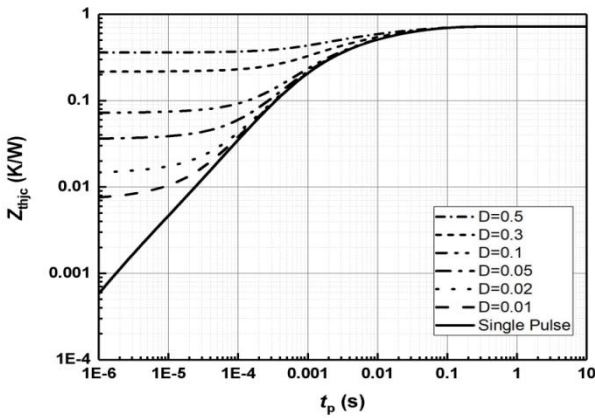

Figure 15. Transient Thermal Impedance (Junction – Case)

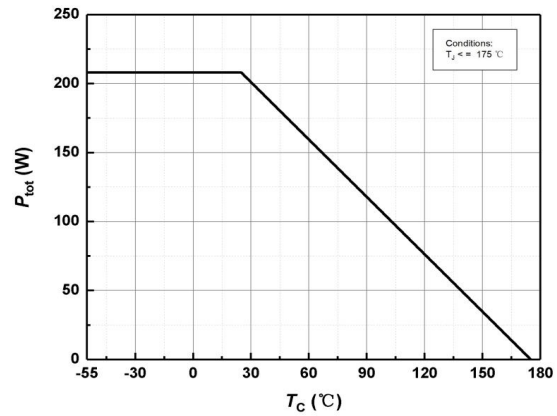

Figure 16. Maximum Power Dissipation Derating vs. Case Temperature

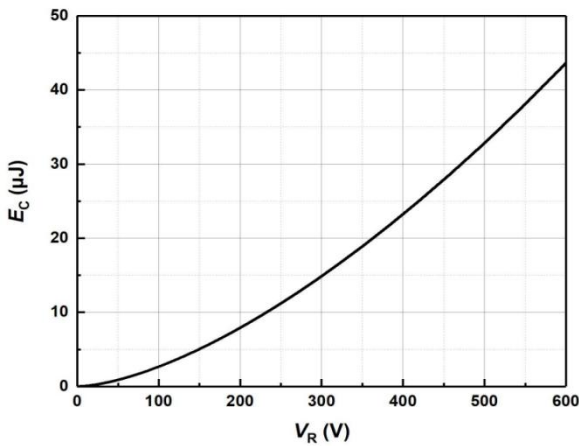

Figure 17. Output Capacitor Stored Energy

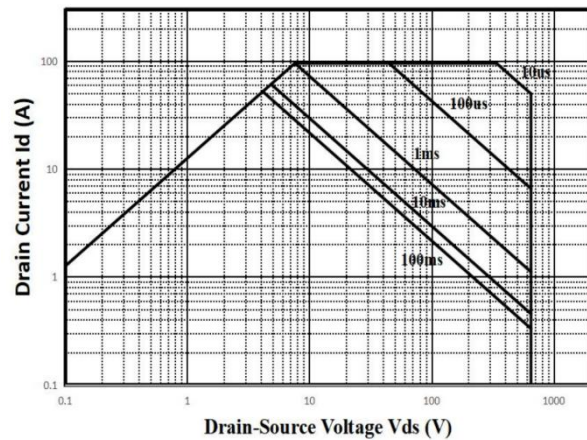

Figure 18. Safe Operating Area

Typical Characteristics

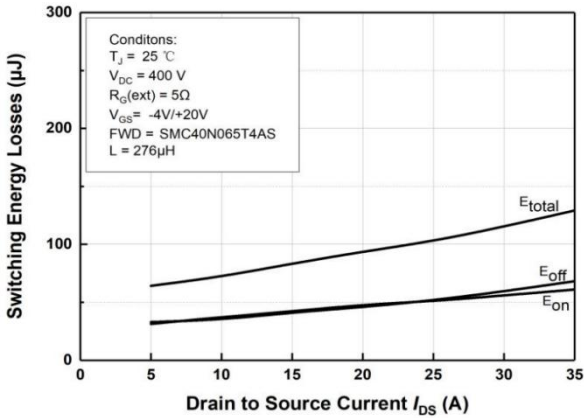

Figure 19. Clamped Inductive Switching Energy vs. Drain Current ($V_{DD} = 600V$)

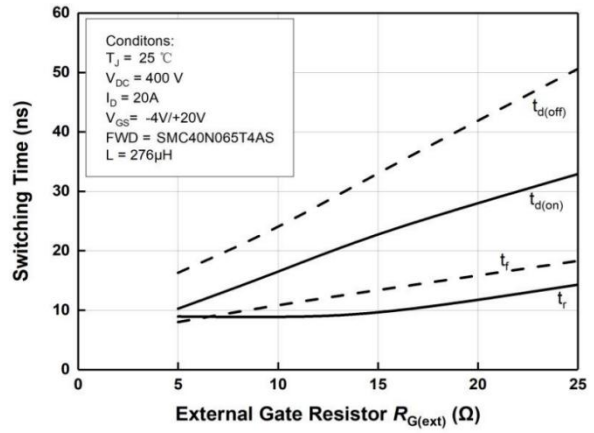

Figure 20. Clamped Inductive Switching Energy vs. $R_{G(ext)}$

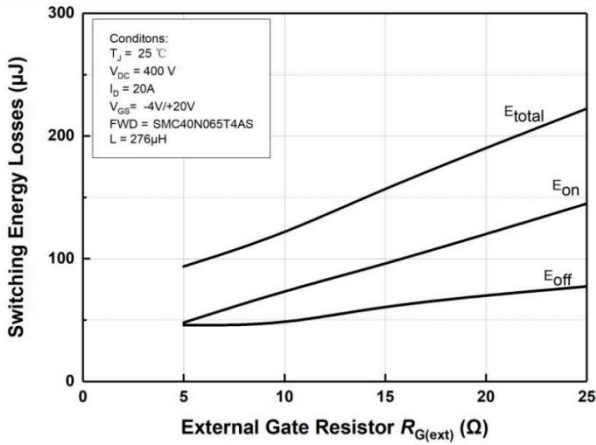
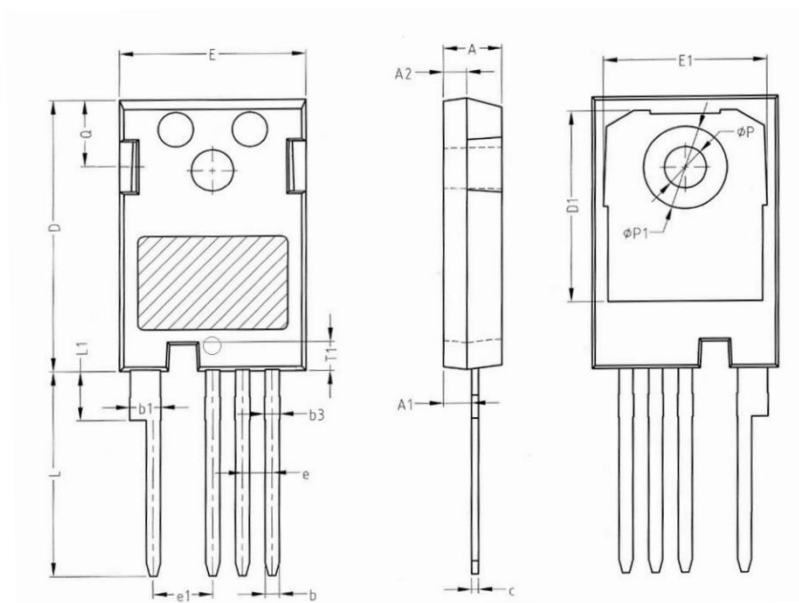

Figure 21. Switching Times vs. $R_{G(ext)}$

TO-247-4 Package Information



Symbol	Dimensions In Millimeters		Dimensions In Inches	
	Min.	Max.	Min.	Max.
A	4.800	5.210	0.189	0.205
A1	2.210	2.610	0.087	0.103
A2	1.800	2.200	0.071	0.087
b	1.060	1.360	0.042	0.054
b1	2.330	2.940	0.092	0.116
b3	1.070	1.600	0.042	0.063
c	0.510	0.750	0.020	0.030
D	23.300	23.600	0.917	0.929
D1	16.250	17.650	0.640	0.695
E	15.740	16.140	0.620	0.635
E1	13.100	14.320	0.516	0.564
T1	2.350	2.650	0.093	0.104
e	2.540 BSC		0.100 BSC	
e1	5.080 BSC		0.200 BSC	
Q	5.490	6.090	0.216	0.240
L	17.270	17.870	0.680	0.704
L1	3.970	4.390	0.156	0.173
φP	3.400	3.800	0.134	0.150
φP1	7.190 REF		0.283 REF	