

Product Summary

$V_{(BR)DSS}$	$R_{DS(on)TYP.}$	$I_D@25^{\circ}C$
750V	11m Ω @18V	218A

Feature

- Wide bandgap SiC MOSFET technology
- Low On-Resistance with High Blocking Voltage
- Low Capacitances with High-Speed switching
- Low reverse recovery(Qrr)

Application

- Switch mode power supplies
- Renewable energy
- Motor drives
- High voltage DC/DC converters

Package

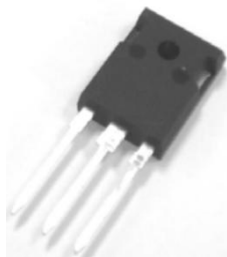

TO-247-3

Marking



Circuit diagram

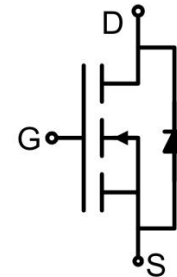

Absolute maximum ratings ($T_C=25^{\circ}C$ unless otherwise noted)

Parameter	Symbol	Test Condition	Value	Unit
Drain-Source Voltage	V_{DSmax}	$V_{GS} = 0V, I_D = 100\mu A$	750	V
Gate-Source Voltage	V_{GSmax}	AC ($f > 1\text{ Hz}$)	-10/+25	V
Gate-Source Voltage	V_{GSOP}	Static	-4/+18	V
Continuous Drain Current	I_D	$V_{GS} = 18V, T_C = 25^{\circ}C$	218	A
	I_D	$V_{GS} = 18V, T_C = 100^{\circ}C$	154	A
Pulsed Drain Current	$I_{D,pulse}$	Pulse with t_p limited by T_{Jmax} at 1 ms	485	A
		Pulse with t_p limited by T_{Jmax} at 100 μs	1157	A
Power Dissipation	P_D	$T_C = 25^{\circ}C$	714	W
Thermal Resistance(Typ.)	$R_{\theta JC}$	Junction-to-Case	0.21	$^{\circ}C/W$
Junction Temperature	T_J		-55 ~ +175	$^{\circ}C$
Storage Temperature	T_{STG}		-55 ~ +175	$^{\circ}C$

Electrical characteristics (T_J=25 °C, unless otherwise noted)

Parameter	Symbol	Test Condition	Min.	Typ.	Max.	Unit
Static Characteristics						
Drain-source breakdown voltage	V _{(BR)DSS}	V _{GS} = 0V, I _D = 100μA	750			V
Zero gate voltage drain current	I _{DSS}	V _{DS} = 750V, V _{GS} = 0V, T _J = 25°C		1	50	μA
Gate-Source leakage current	I _{GSS}	V _{GS} = 18V, V _{DS} = 0V			250	nA
Gate threshold voltage	V _{GS(th)}	V _{DS} = V _{GS} , I _D = 36mA		2.7		V
		V _{DS} = V _{GS} , I _D = 36mA, T _J = 175°C		1.8		
Drain-source on-resistance	R _{DS(on)}	V _{GS} = 18V, I _D = 80A		11	15	mΩ
		V _{GS} = 18V, I _D = 80A, T _J = 175°C		15		
Transconductance	g _{fs}	V _{GS} = 18V, I _D = 80A		83		S
		V _{GS} = 18V, I _D = 80A, T _J = 175°C		66		
Dynamic characteristics						
Input Capacitance	C _{iss}	V _{DS} = 600V, V _{GS} = 0V, f = 1MHz V _{AC} = 25mV		6220		pF
Output Capacitance	C _{oss}			482		
Reverse Transfer Capacitance	C _{rss}			37		
Total Gate Charge	Q _g	V _{DS} = 400V, V _{GS} = -4V/18V, I _D = 80A		268		nC
Gate-Source Charge	Q _{gs}			125		
Gate-Drain Charge	Q _{gd}			52		
Internal Gate Resistance	R _{G(int)}	f = 1MHz, V _{AC} = 25mV		1		Ω
Source-Drain Diode characteristics						
Diode Forward Current	I _S	V _{GS} = -4V, T _C = 25°C		142		A
Diode Forward voltage	V _{SD}	V _{GS} = -4V, I _{SD} = 20A		3.5		V
		V _{GS} = -4V, I _{SD} = 20A, T _J = 175°C		3.1		
Diode Pulse Current	I _{S, pulse}	V _{GS} = -4V, pulse width t _p limited by T _{Jmax}		485		A

Typical Characteristics

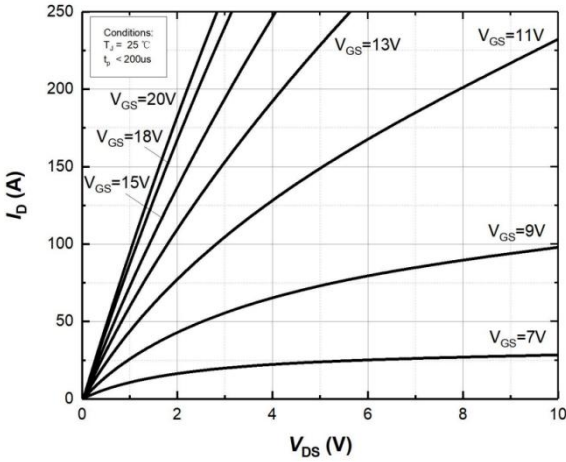

Figure 1. Output characteristics at $T_j=25^\circ\text{C}$

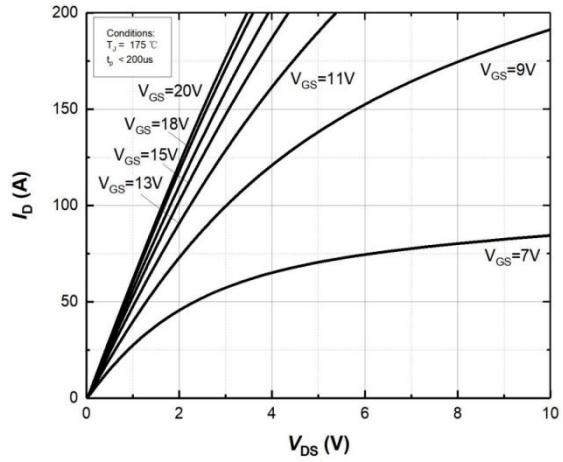

Figure 2. Output characteristics at $T_j=175^\circ\text{C}$

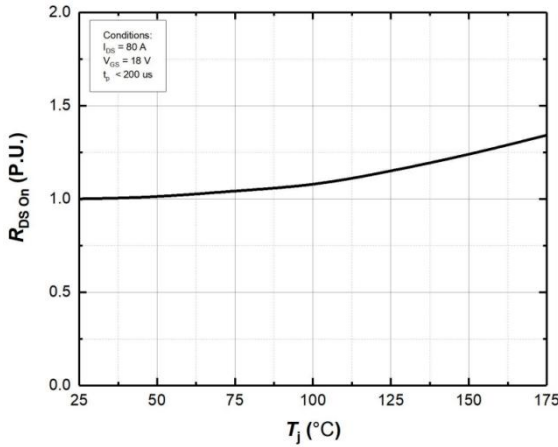

Figure 3. Normalized On-Resistance vs. Temperature

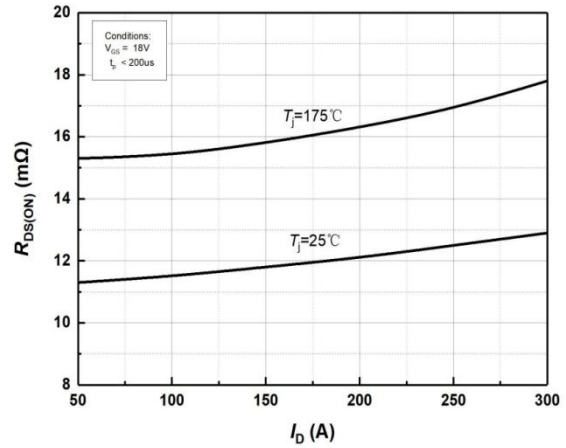

Figure 4. On-Resistance vs. Drain current for Various Temperature

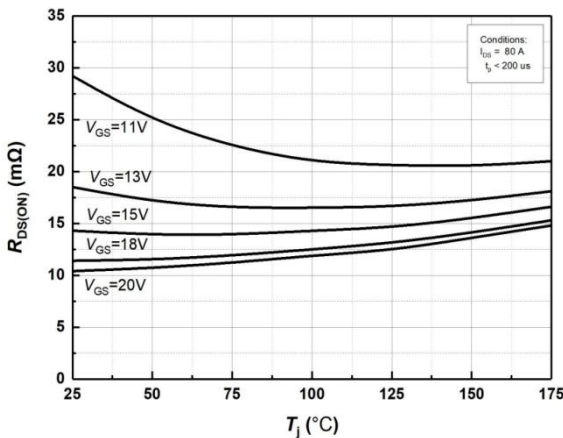

Figure 5. On-Resistance vs. Temperature for Various Gate Voltage

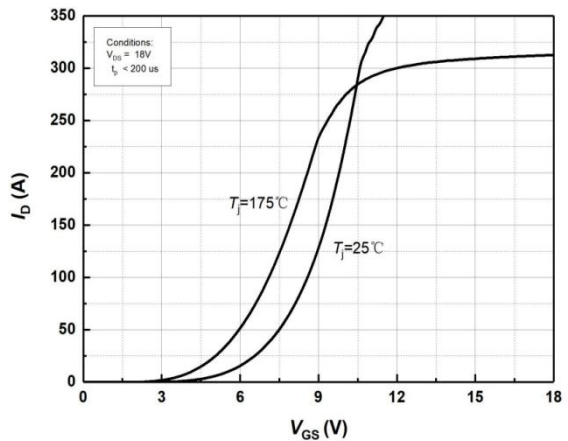

Figure 6. Transfer Characteristics for Various Junction Temperatures

Typical Characteristics

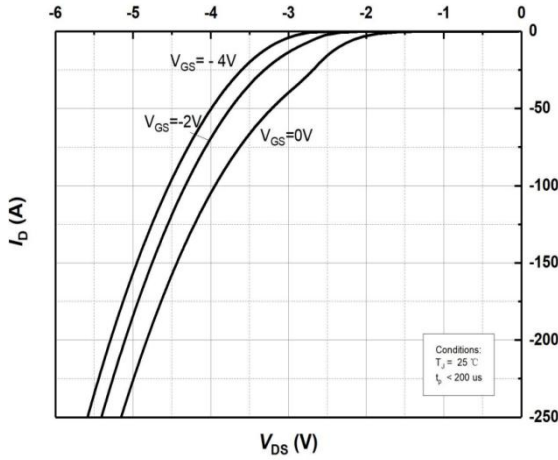

Figure 7. Body Diode Characteristics at $T_j=25^\circ\text{C}$

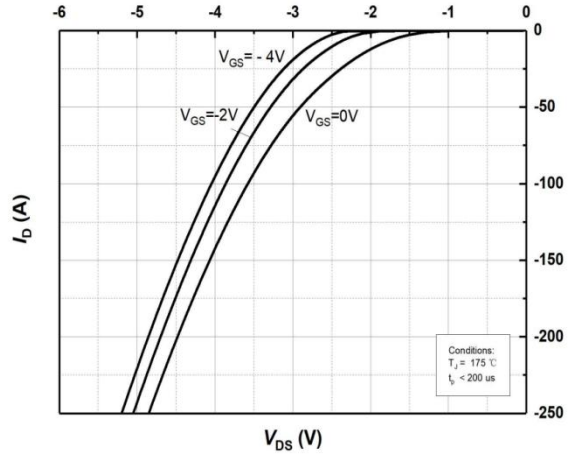

Figure 8. Body Diode Characteristics at $T_j=175^\circ\text{C}$

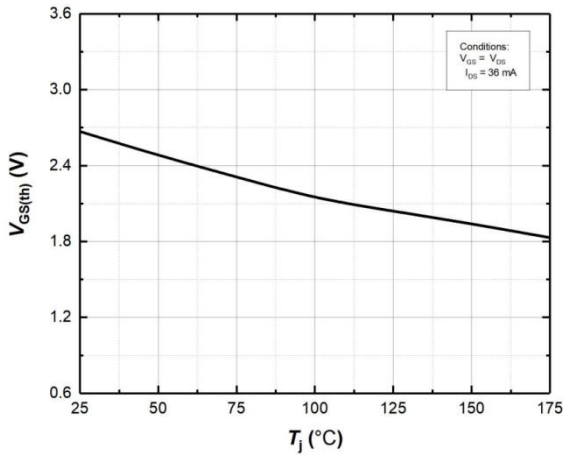

Figure 9. Threshold Voltage vs. Temperature

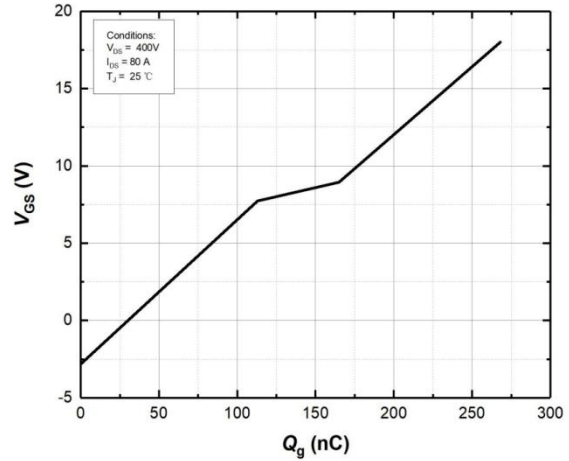

Figure 10. Gate Charge Characteristics

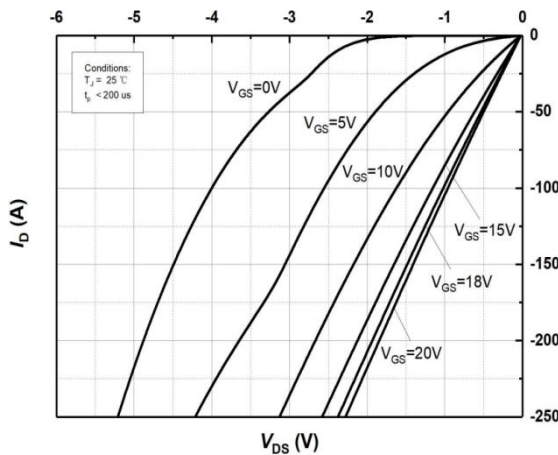

Figure 11. 3rd Quadrant Characteristic at $T_j=25^\circ\text{C}$

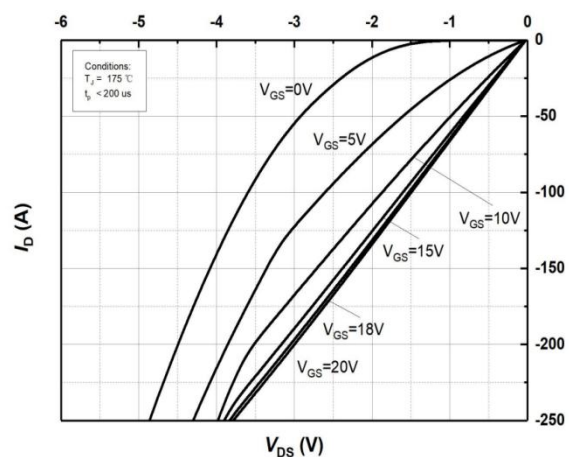

Figure 12. 3rd Quadrant Characteristic at $T_j=175^\circ\text{C}$

Typical Characteristics

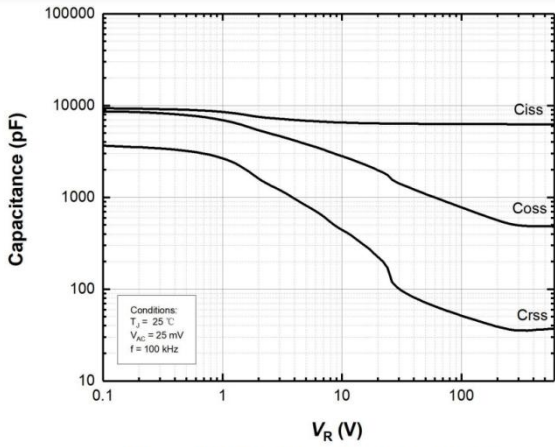

Figure 13. Capacitances vs. Drain-Source Voltage (0 - 1000V)

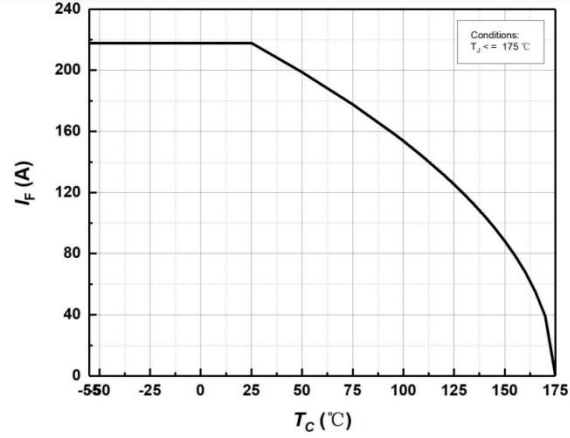

Figure 14. Continuous Drain Current Derating vs Case Temperature

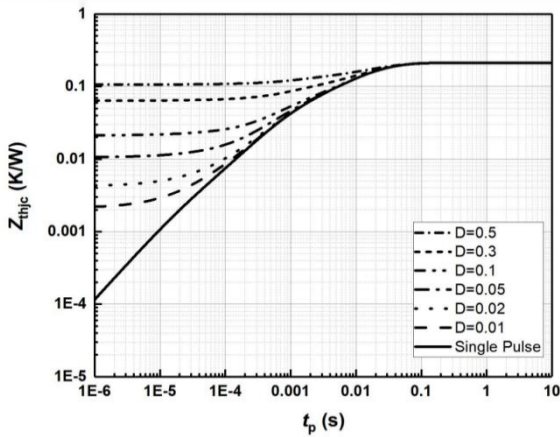

Figure 15. Transient Thermal Impedance (Junction - Case)

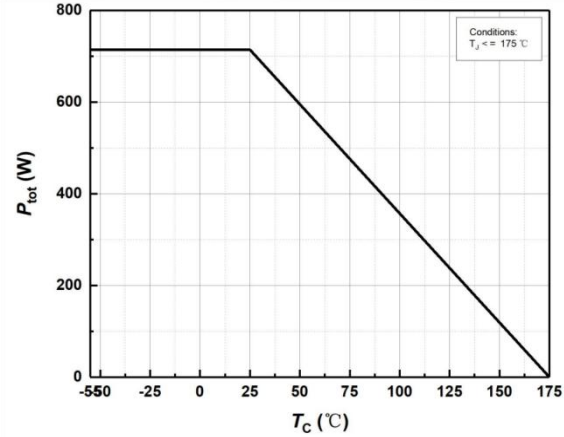

Figure 16. Maximum Power Dissipation Derating vs. Case Temperature

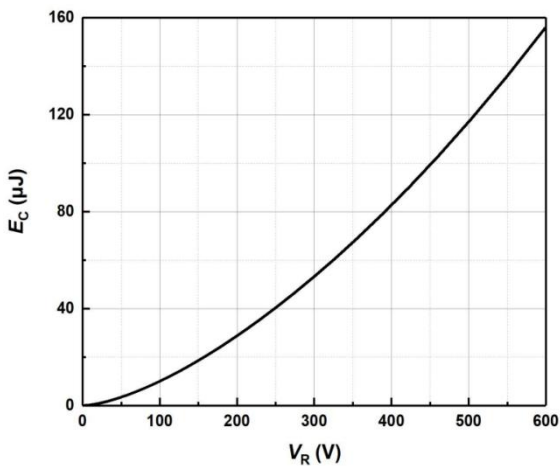

Figure 17. Output Capacitor Stored Energy

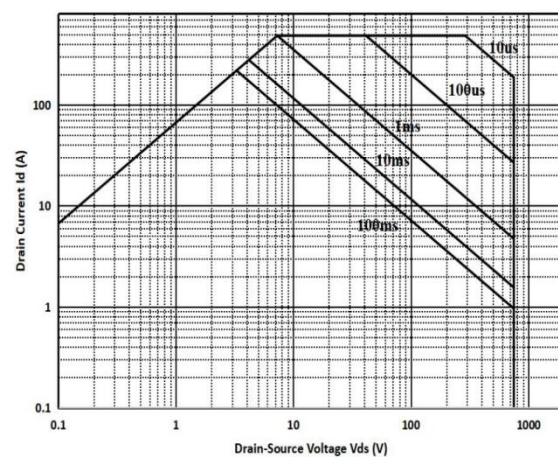
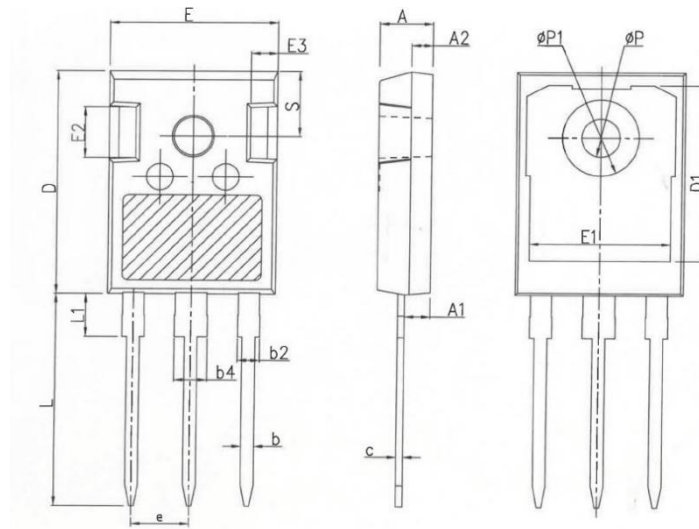

Figure 18. Safe Operating Area

TO-247-3 Package Information



Symbol	Dimensions In Millimeters		Dimensions In Inches	
	Min.	Max.	Min.	Max.
A	4.800	5.200	0.189	0.205
A1	2.210	2.590	0.087	0.102
A2	1.850	2.150	0.073	0.085
b	1.110	1.360	0.044	0.054
b2	1.910	2.210	0.075	0.087
b4	2.910	3.210	0.115	0.126
c	0.510	0.750	0.020	0.030
D	20.700	21.300	0.815	0.839
D1	16.250	16.850	0.640	0.663
E	15.500	16.100	0.610	0.634
E1	13.000	13.600	0.512	0.535
E2	4.800	5.200	0.189	0.205
E3	2.300	2.700	0.091	0.106
e	5.440 BSC		0.214 BSC	
L	19.620	20.220	0.772	0.796
L1	-	4.300	-	0.169
ϕP	3.400	3.800	0.134	0.150
$\phi P1$	-	7.300	-	0.287
S	6.150 BSC		0.242 BSC	