

### FEATURES:

- ✧ Protects one bi-directional I/O line
- ✧ Low clamping voltage
- ✧ Low operating voltage: 7.0V
- ✧ Ultra-low capacitance
- ✧ ROHS compliant
- ✧ Compliant to Halogen-free



DFN-2L(0402)

### MAIN APPLICATIONS

- ✧ Cellular handsets
- ✧ USB V<sub>BUS</sub> and CC line protection
- ✧ Microphone line protection
- ✧ GPIO protection

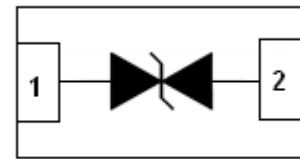

PIN Configuration

### PROTECTION SOLUTION TO MEET

- ✧ IEC61000-4-2 (ESD) ±20kV (air), ±20kV (contact)
- ✧ IEC61000-4-5 (Lightning) 6A (8/20μs)

### MECHANICAL CHARACTERISTICS

- ✧ Package DFN-2L(0402)
- ✧ Molding Compound Flammability Rating : UL 94V-O
- ✧ Quantity Per Reel : 10,000pcs
- ✧ Lead Finish : Lead Free
- ✧ Marking Code: D8 or 7A

### ABSOLUTE MAXIMUM RATINGS (T<sub>A</sub>=25°C, RH=45%-75%, unless otherwise noted)

Parameter	Symbol	Value	Unit
Peak pulse power dissipation on 8/20μs waveform	P <sub>PP</sub>	80	W
ESD per IEC 61000-4-2 (Air)	V <sub>ESD</sub>	+/- 20	kV
ESD per IEC 61000-4-2 (Contact)		+/- 20	
Lead soldering temperature	T <sub>L</sub>	260 (10 sec.)	°C
Operating junction temperature range	T <sub>J</sub>	-55 to +125	°C
Storage temperature range	T <sub>STG</sub>	-55 to +150	°C

**ELECTRICAL CHARACTERISTICS** ( $T_A=25^\circ\text{C}$ )

Parameter	Symbol	Conditions	Min	Typ	Max	Units
Reverse Working Voltage	$V_R$				7.0	V
Reverse Breakdown Voltage	$V_{BR}$	$I_T = 1\text{mA}$	7.2			V
Reverse Leakage Current	$I_R$	$V_R = 7\text{V}$			0.2	$\mu\text{A}$
Peak Pulse Current	$I_{PP}$	$t_p = 8/20\mu\text{s}$			6	A
Clamping Voltage	$V_C$	$I_{PP} = 1\text{A}, t_p = 8/20\mu\text{s}$			11	V
		$I_{PP} = 6\text{A}, t_p = 8/20\mu\text{s}$			14	V
Junction Capacitance	$C_J$	$V_R = 0\text{V}, f = 1\text{MHz}$		15		pF

**RATINGS AND V-I CHARACTERISTICS CURVES** ( $T_A=25^\circ\text{C}$ , unless otherwise noted)

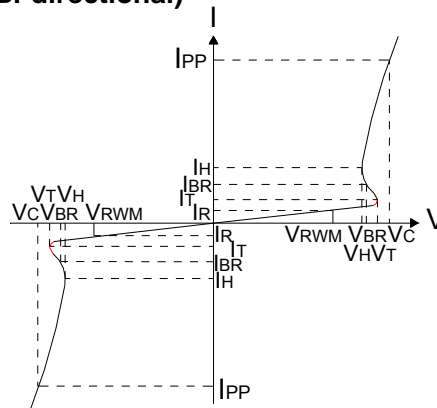
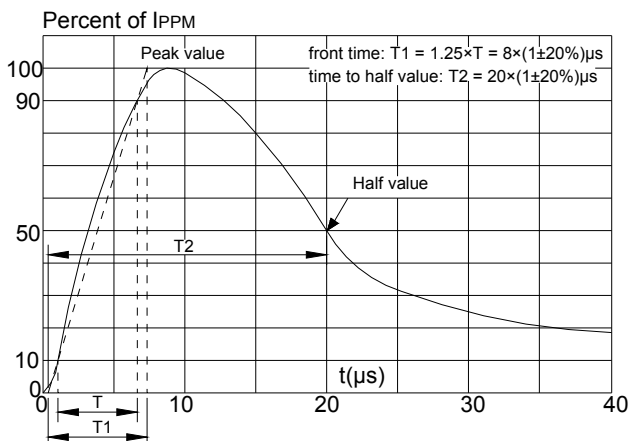
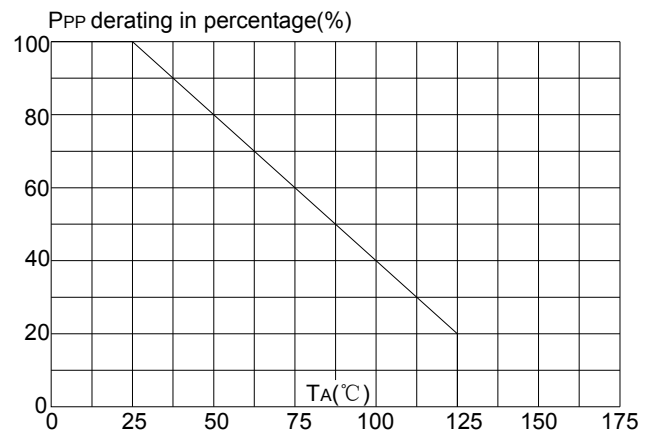
**FIG.1: V- I curve characteristics (Bi-directional)**

**FIG.2: Pulse waveform (8/20 $\mu\text{s}$ )**

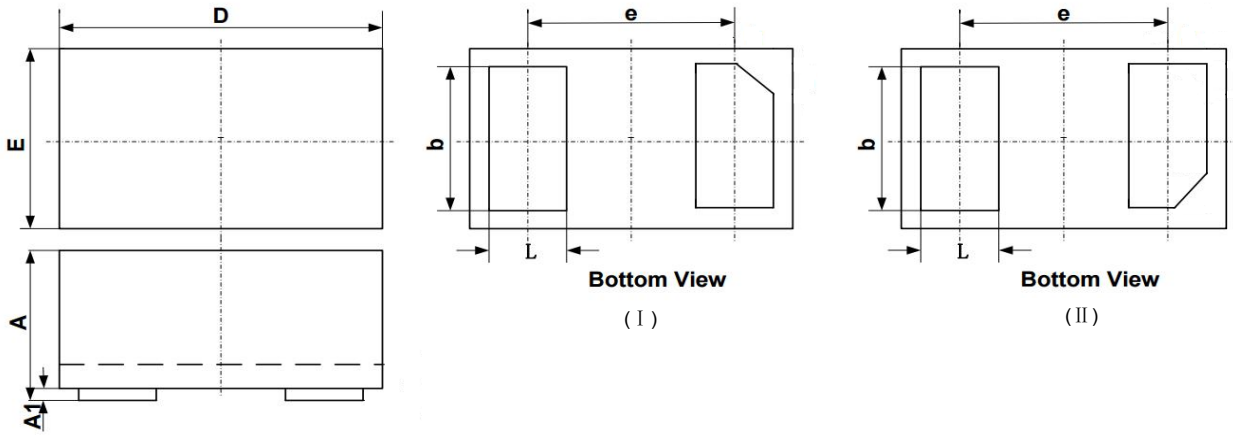
**FIG.3: Pulse derating curve**

## PACKAGE MECHANICAL DATA



SYM	DIMENSIONS					
	MILLIMETERS			INCHES		
	MIN	NOM	MAX	MIN	NOM	MAX
A	0.40	0.50	0.55	0.015	0.020	0.022
A1	0.00	0.02	0.05	0.000	0.001	0.002
b	0.45	0.50	0.55	0.018	0.020	0.022
D	0.95	1.00	1.05	0.037	0.039	0.041
e	0.65 BSC			0.026 BSC		
E	0.55	0.60	0.65	0.022	0.024	0.026
L	0.20	0.25	0.30	0.008	0.010	0.012