

Product Summary

$V_{(BR)DSS}$	$R_{DS(on)MAX}$	I_D
60V	44mΩ@10V	5A
	50mΩ@4.5V	

Feature

- High density cell design for ultra low Rdson
- Fully characterized Avalanche voltage and current

Application

- Power switching application
- Hard Switched and High Frequency Circuits
- Uninterruptible Power Supply

Package



SOP-8

Circuit diagram

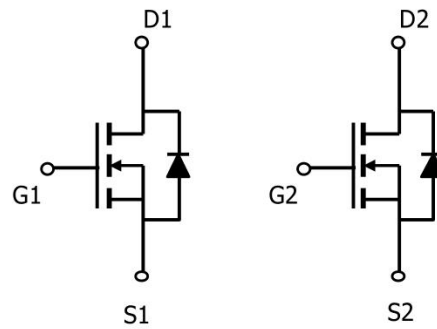

Marking

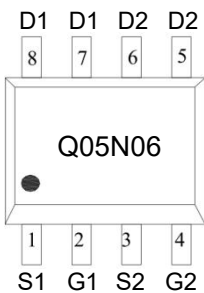

Absolute maximum ratings (Ta=25°C unless otherwise noted)

Parameter	Symbol	Value	Unit
Drain-Source Voltage	V _{DS}	60	V
Gate-Source Voltage	V _{GS}	±20	V
Continuous Drain Current	I _D	5	A
Pulsed Drain Current	I _{DM}	20	A
Power Dissipation	P _D	2	W
Thermal Resistance from Junction to Ambient	R _{θJA}	62.5	°C/W
Junction Temperature	T _J	150	°C
Storage Temperature	T _{STG}	-55 ~ +150	°C

Electrical characteristics (T_A=25 °C, unless otherwise noted)

Parameter	Symbol	Test Condition	Min.	Typ.	Max.	Unit
Static Characteristics						
Drain-source breakdown voltage	V _{(BR)DSS}	V _{GS} = 0V, I _D = 250μA	60			V
Zero gate voltage drain current	I _{DSS}	V _{DS} = 60V, V _{GS} = 0V			1	μA
Gate-body leakage current	I _{GSS}	V _{GS} = ±20V, V _{DS} = 0V			±100	nA
Gate threshold voltage	V _{GS(th)}	V _{DS} = V _{GS} , I _D = 250μA	1.0	1.5	2.5	V
Drain-source on-resistance ¹⁾	R _{DS(on)}	V _{GS} = 10V, I _D = 5A		35	44	mΩ
		V _{GS} = 4.5V, I _D = 4A		39	50	
Dynamic characteristics²⁾						
Input Capacitance	C _{iss}	V _{DS} = 30V, V _{GS} = 0V, f = 1MHz		800		pF
Output Capacitance	C _{oss}			72		
Reverse Transfer Capacitance	C _{rss}			38		
Total Gate Charge	Q _g	V _{DS} = 30V, V _{GS} = 10V, I _D = 5A		15		nC
Gate-Source Charge	Q _{gs}			2.4		
Gate-Drain Charge	Q _{gd}			2.5		
Turn-on delay time	t _{d(on)}	V _{DD} = 30V, V _{GS} = 10V, I _D = 2A R _L = 1Ω, R _{GEN} = 3Ω		5		nS
Turn-on rise time	t _r			39		
Turn-off delay time	t _{d(off)}			19		
Turn-off fall time	t _f			7		
Source-Drain Diode characteristics						
Diode Forward Current ¹⁾	I _S				5	A
Diode Forward voltage	V _{DS}	V _{GS} = 0V, I _S = 5A			1.2	V

Notes:

- 1) Pulse Test: Pulse Width < 300μs, Duty Cycle ≤ 2%.
- 2) Guaranteed by design, not subject to production testing.

Typical Characteristics

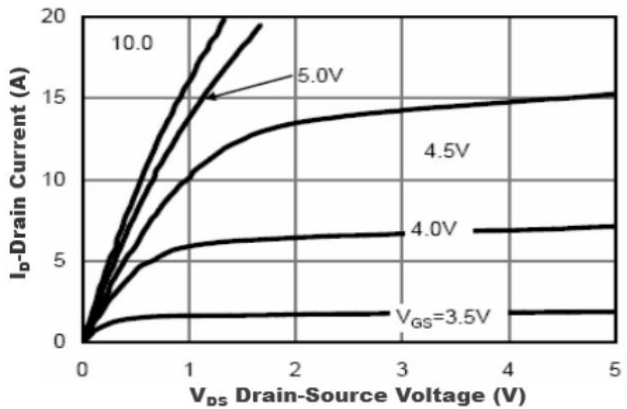

Figure1. Output Characteristics

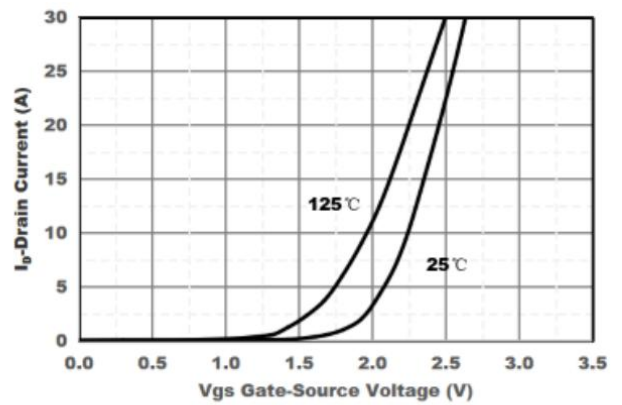

Figure2. Transfer Characteristics

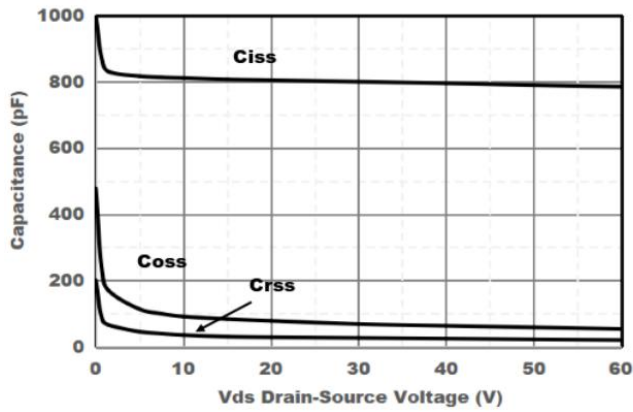

Figure3. Capacitance Characteristics

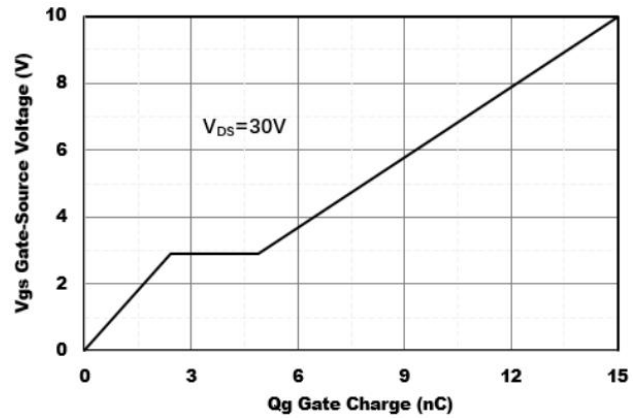

Figure4. Gate Charge

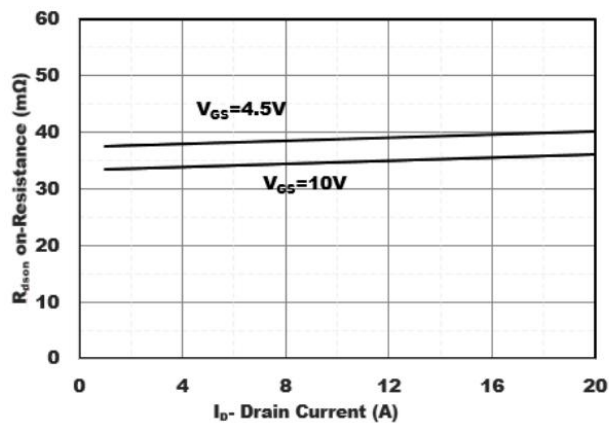

Figure5. Drain-Source on Resistance

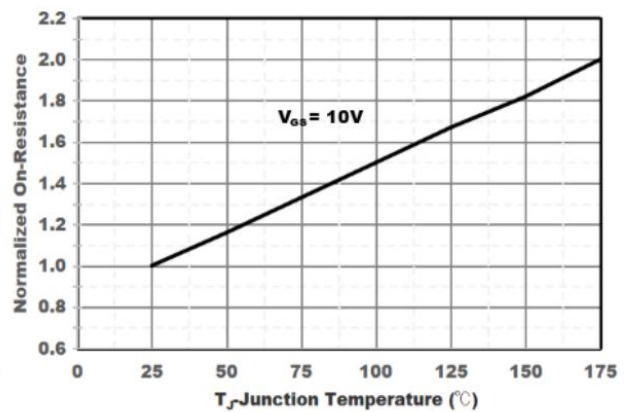

Figure6. Drain-Source on Resistance

Typical Characteristics

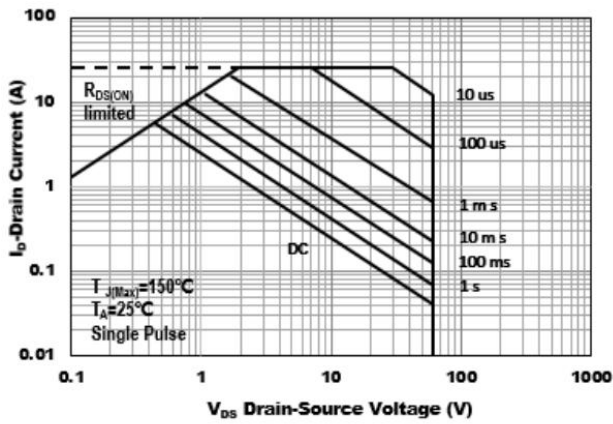

Figure7. Safe Operation Area

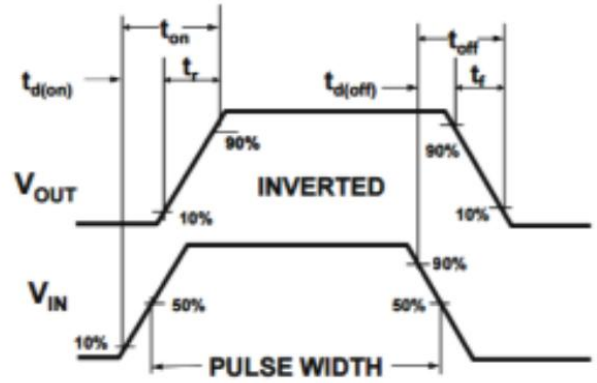
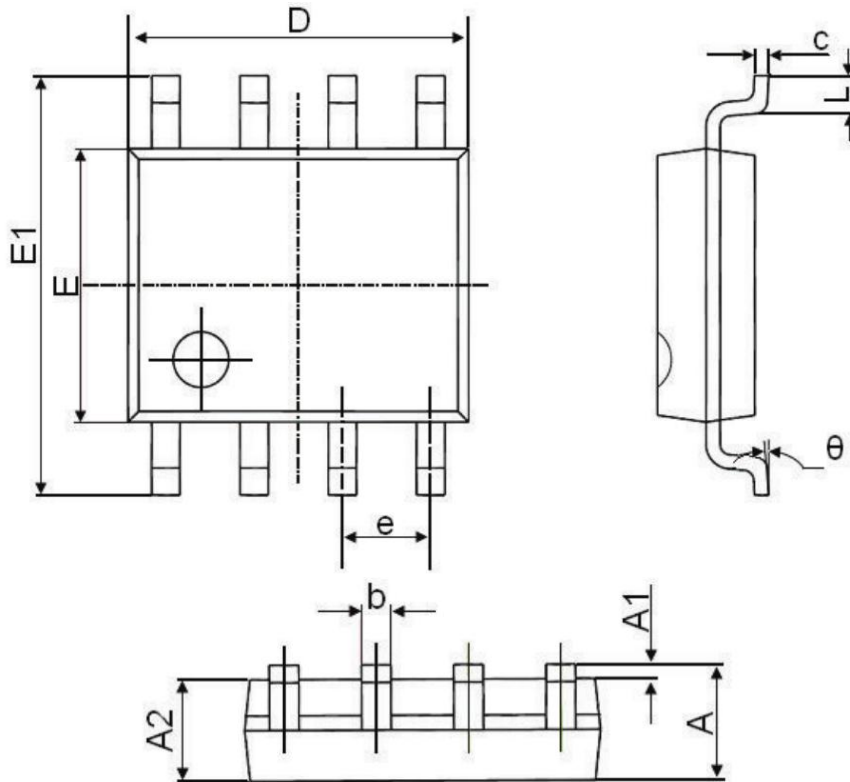

Figure8. Switching wave

SOP-8 Package Information



Symbol	Dimensions In Millimeters		Dimensions In Inches	
	Min.	Max.	Min.	Max.
A	1.350	1.750	0.053	0.069
A1	0.100	0.250	0.004	0.010
A2	1.350	1.550	0.053	0.061
b	0.330	0.510	0.013	0.020
c	0.170	0.250	0.006	0.010
D	4.700	5.100	0.185	0.200
E	3.800	4.000	0.150	0.157
E1	5.800	6.200	0.228	0.244
e	1.270(BSC)		0.050(BSC)	
L	0.400	1.270	0.016	0.050
θ	0°	8°	0°	8°