

Product Summary

$V_{(BR)DSS}$	$R_{DS(on)MAX}$	$I_D@25^{\circ}C$
650V	50mΩ@18V	55A

Feature

- High Blocking Voltage With Low On-Resistance
- High Speed Switching With Low Capacitance
- Fast Intrinsic Diode with Low Reverse Recovery (Qrr)

Application

- EV motor drive
- Server Power Supplies
- Solar PV Inverters
- UPS
- DC/DC Converters

Package

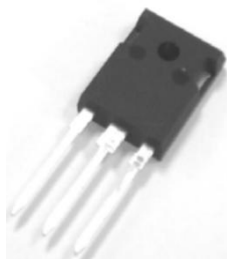

TO-247-3

Marking



Circuit diagram

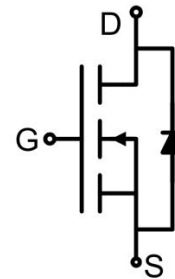

Absolute maximum ratings ($T_c=25^{\circ}C$ unless otherwise noted)

Parameter	Symbol	Test Condition	Value	Unit
Drain-Source Voltage	V_{DSmax}	$V_{GS} = 0V, I_D = 100\mu A$	650	V
Gate-Source Voltage	V_{GSmax}	Absolute maximum values	-8/+22	V
Gate-Source Voltage	V_{GSOP}	Recommended operational values	-5/+18	V
Continuous Drain Current	I_D	$V_{GS}=18V, T_c=25^{\circ}C$	55	A
	I_D	$V_{GS}=18V, T_c=100^{\circ}C$	39	A
Power Dissipation	P_D	$T_c=25^{\circ}C$	187	W
Thermal Resistance (Max)	$R_{\theta JC}$	Junction-to-Case	0.8	$^{\circ}C/W$
Junction Temperature	T_J		-55 ~ +175	$^{\circ}C$
Storage Temperature	T_{STG}		-55 ~ +175	$^{\circ}C$

Electrical characteristics (T_c=25°C unless otherwise noted)

Parameter	Symbol	Test Condition	Min.	Typ.	Max.	Unit
Static Characteristics						
Drain-source breakdown voltage	V _{(BR)DSS}	V _{GS} = 0V, I _D = 1mA	650			V
Zero gate voltage drain current	I _{DSS}	V _{DS} = 650V, V _{GS} = 0V		1	50	μA
Gate-Source leakage current	I _{GSS}	V _{GS} = 22V, V _{DS} = 0V		10	250	nA
Gate threshold voltage	V _{GS(th)}	V _{DS} = V _{GS} , I _D = 10mA	1.8	2.6	4.3	V
Drain-source on-resistance	R _{DS(on)}	V _{GS} = 18V, I _D = 25A		30	50	mΩ
		V _{GS} = 18V, I _D = 25A, T _J = 175°C		42		
Dynamic characteristics						
Input Capacitance	C _{iss}	V _{DS} = 400V, V _{GS} = 0V, f = 1MHz V _{AC} = 25mV		1850		pF
Output Capacitance	C _{oss}			160		
Reverse Transfer Capacitance	C _{rss}			15		
Turn-on Switching Energy	E _{on}	V _{DS} = 400V, V _{GS} = -5V/18V, I _D = 25A, R _{G(ext)} = 2.5Ω, L = 100μH		50		μJ
Turn-off Switching Energy	E _{off}			65		
Total Gate Charge	Q _g	V _{DS} = 400V, V _{GS} = -5V/18V, I _D = 25A		110		nC
Gate-Source Charge	Q _{gs}			30		
Gate-Drain Charge	Q _{gd}			32		
Turn-on delay time	t _{d(on)}	V _{DS} = 400V, V _{GS} = -5V/18V, I _D = 25A, R _{G(ext)} = 2.5Ω, R _L = 16Ω		14		nS
Turn-on rise time	t _r			15		
Turn-off delay time	t _{d(off)}			28		
Turn-off fall time	t _f			8		
Source-Drain Diode characteristics						
Diode Forward Current	I _S	V _{GS} = -5V			45	A
Diode Forward voltage	V _{SD}	V _{GS} = -5V, I _{SD} = 12.5A		4.2		V
		V _{GS} = -5V, I _{SD} = 12.5A, T _J = 175°C		3.8		
Reverse Recovery Time	t _{rr}	I _{SD} = 25A, V _R = 400V		25		nS
Reverse Recovery Charge	Q _{rr}			100		nC
Peak Reverse Recovery Current	I _{rrm}			5		A

Typical Characteristics

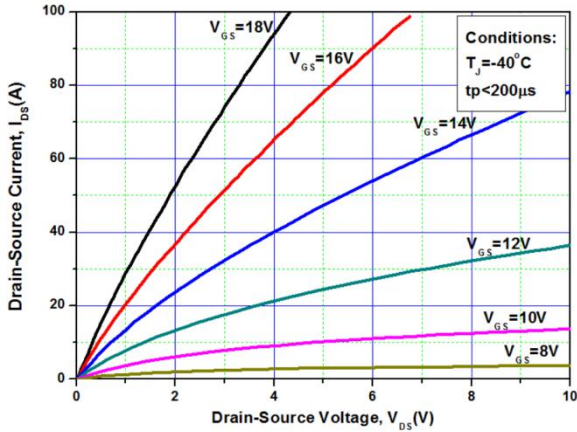

Figure 1. Output Characteristics $T_j = -40^\circ\text{C}$

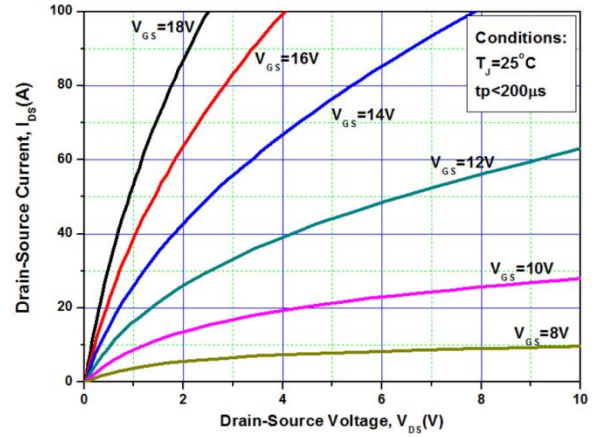

Figure 2. Output Characteristics $T_j = 25^\circ\text{C}$

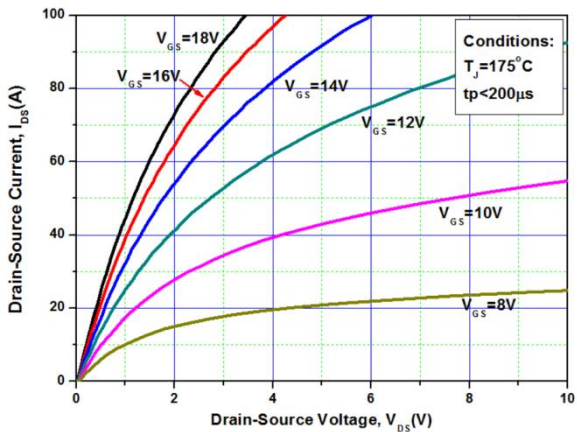

Figure 3. Output Characteristics $T_j = 175^\circ\text{C}$

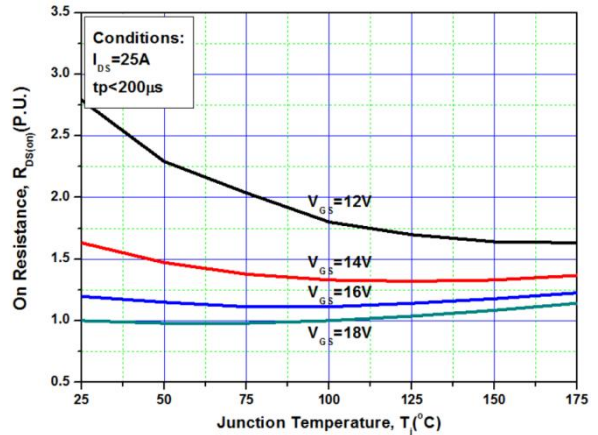

Figure 4. Normalized On-Resistance vs. Temperature

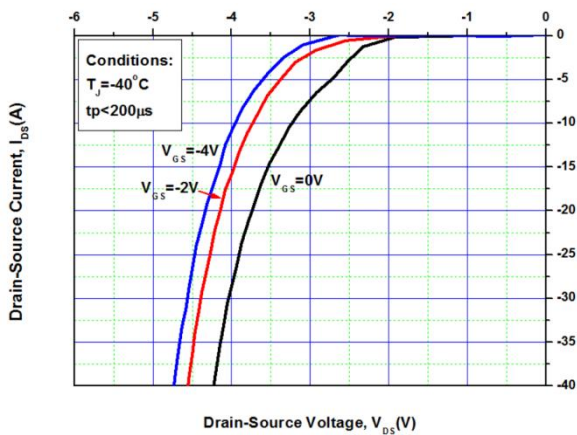

Figure 5. Body Diode Characteristic at -40°C

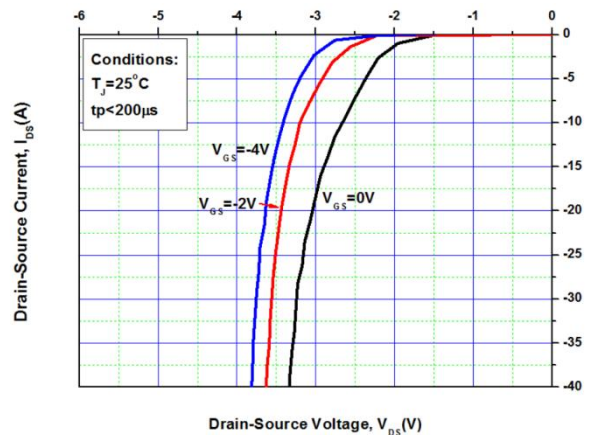

Figure 6. Body Diode Characteristic at 25°C

Typical Characteristics

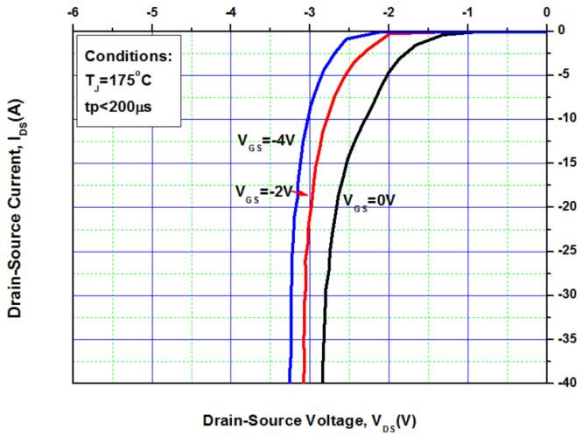

Figure 7. Body Diode Characteristic at 175°C

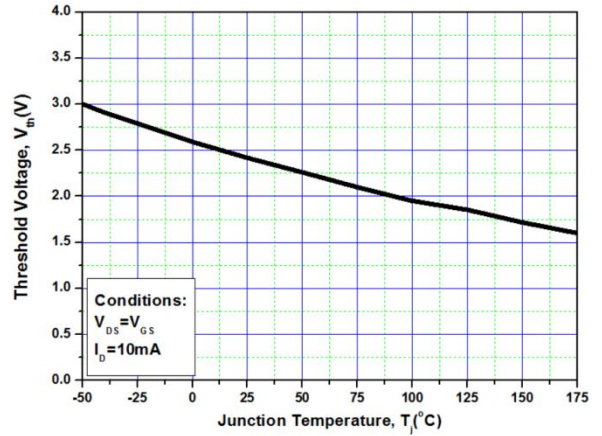

Figure 8. Threshold Voltage vs. Temperature

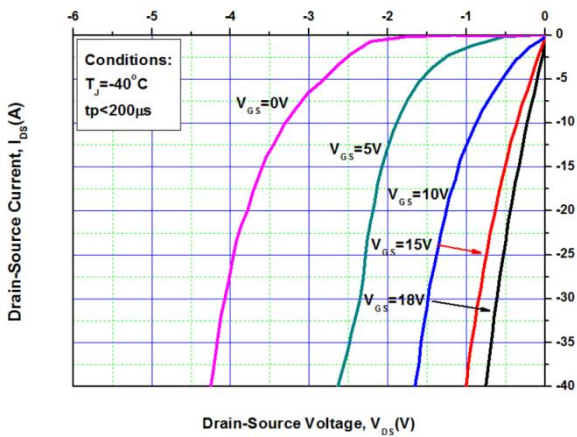

Figure 9. 3rd Quadrant Characteristic at -40°C

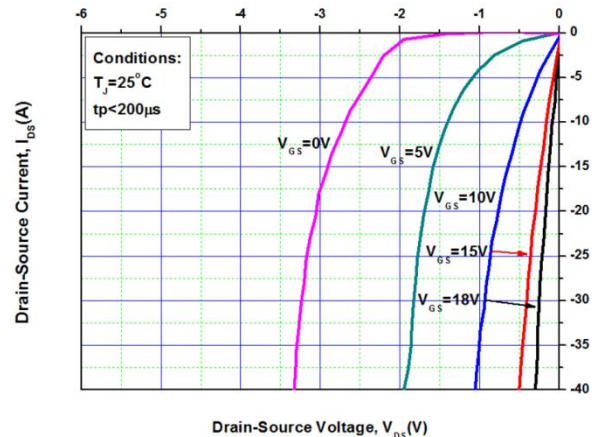

Figure 10. 3rd Quadrant Characteristic at 25°C

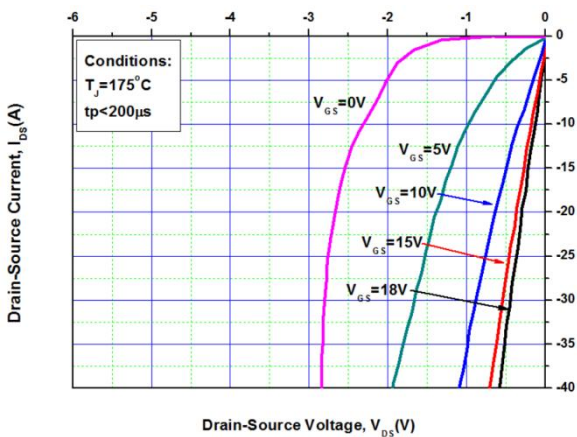

Figure 11. 3rd Quadrant Characteristic at 175°C

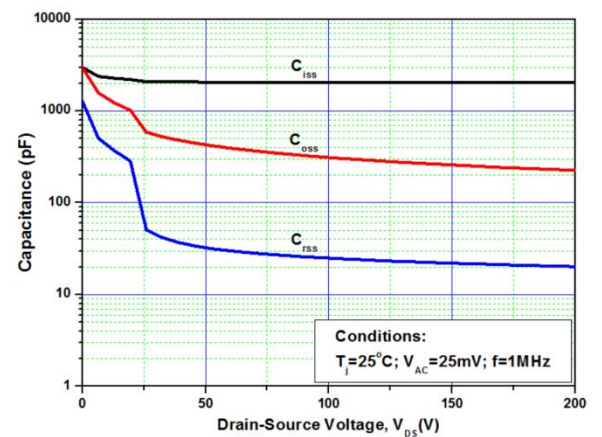

Figure 12. Capacitances vs. Drain-Source Voltage (0 - 200V)

Typical Characteristics

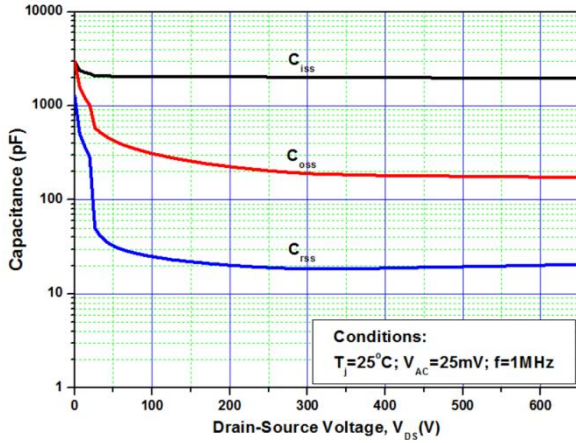
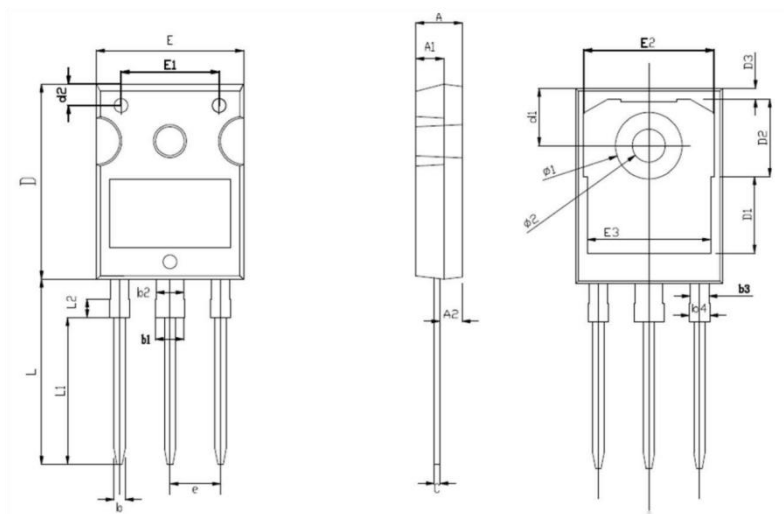

Figure 13. Capacitances vs. Drain-Source Voltage (0 - 650V)

TO-247-3 Package Information



Symbol	Dimensions In Millimeters		Dimensions In Inches	
	Min.	Max.	Min.	Max.
A	4.800	5.200	0.189	0.205
A1	2.800	3.200	0.110	0.126
A2	2.260	2.560	0.089	0.101
b	1.100	1.300	0.043	0.051
b1	2.900	3.200	0.114	0.126
b2	2.900	3.100	0.114	0.122
b3	1.900	2.100	0.075	0.083
b4	2.000	2.200	0.079	0.086
c	0.500	0.700	0.020	0.028
D	20.800	21.200	0.819	0.835
D1	8.230 BSC		0.324 BSC	
D2	8.320 BSC		0.328 BSC	
D3	1.170 BSC		0.046 BSC	
d1	6.000	6.300	0.236	0.248
d2	2.200	2.400	0.087	0.094
E	15.600	16.00	0.614	0.630
E1	10.500 BSC		0.413 BSC	
E2	14.020 BSC		0.552 BSC	
E3	13.500 BSC		0.531 BSC	
e	5.340	5.540	0.210	0.218
L	19.720	20.120	0.776	0.792
L1	15.790 BSC		0.621 BSC	
L2	1.980 BSC		0.078 BSC	
φ1	7.100	7.300	0.280	0.287
φ2	3.500	3.700	0.138	0.146