

Product Summary

$V_{(BR)DSS}$	$R_{DS(on)MAX}$	I_D
200V	80mΩ@10V	18A

Feature

- Excellent gate charge x $R_{DS(on)}$ product(FOM)
- Very low on-resistance $R_{DS(on)}$

Application

- DC/DC converters
- Ideal for high-frequency switching and synchronous rectification

Package

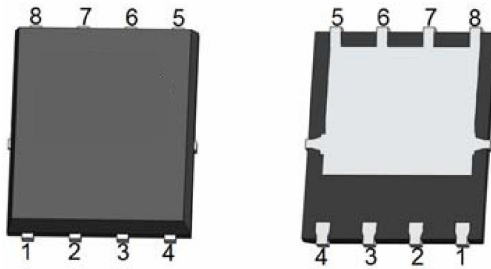

DFN5X6-8L

Circuit diagram

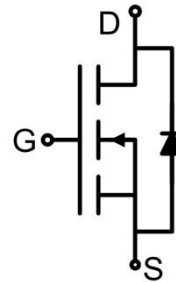

Marking

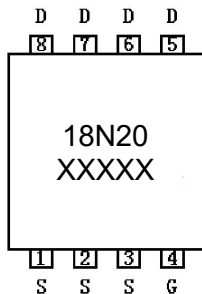

Absolute maximum ratings (T_A=25°C unless otherwise noted)

Parameter	Symbol	Value	Unit
Drain-Source Voltage	V _{DS}	200	V
Gate-Source Voltage	V _{GS}	±20	V
Continuous Drain Current	I _D	18	A
Continuous Drain Current (T _C =100°C)	I _D (100°C)	12.6	A
Pulsed Drain Current	I _{DM}	72	A
Power Dissipation	P _D	105	W
Thermal Resistance,Junction-to-Case ¹⁾	R _{θJC}	1.2	°C/W
Single pulse avalanche energy ⁴⁾	E _{AS}	180	mJ
Junction Temperature	T _J	150	°C
Storage Temperature	T _{STG}	-55 ~ +150	°C

Electrical characteristics (T_A=25 °C unless otherwise noted)

Parameter	Symbol	Test Condition	Min.	Typ.	Max.	Unit
Static Characteristics						
Drain-source breakdown voltage	V _{(BR)DSS}	V _{GS} = 0V, I _D =250μA	200			V
Zero gate voltage drain current	I _{DSS}	V _{DS} =200V, V _{GS} = 0V			1	μA
Gate-body leakage current	I _{GSS}	V _{GS} =±20V, V _{DS} = 0V			±100	nA
Gate threshold voltage ²⁾	V _{GS(th)}	V _{DS} =V _{GS} , I _D =250μA	2.5	3.5	4.5	V
Drain-source on-resistance ²⁾	R _{DS(on)}	V _{GS} =10V, I _D =18A		70	80	mΩ
Forward Transconductance ²⁾	g _{FS}	V _{DS} =5V, I _D =18A	15			S
Dynamic characteristics³⁾						
Input Capacitance	C _{iss}	V _{DS} =100V, V _{GS} =0V, f =1MHz		951		pF
Output Capacitance	C _{oss}			82		
Reverse Transfer Capacitance	C _{rss}			2		
Total Gate Charge	Q _g	V _{DS} =100V, V _{GS} =10V, I _D =18A		18		nC
Gate-Source Charge	Q _{gs}			7.5		
Gate-Drain Charge	Q _{gd}			4.6		
Turn-on delay time	t _{d(on)}	V _{DD} =100V, V _{GS} =10V, R _G =3Ω, R _L =5.5Ω		6		nS
Turn-on rise time	t _r			7		
Turn-off delay time	t _{d(off)}			15		
Turn-off fall time	t _f			4		
Source-Drain Diode characteristics						
Diode Forward Current ¹⁾	I _S				18	A
Diode Forward voltage ²⁾	V _{SD}	V _{GS} =0V, I _S =18A			1.2	V
Reverse Recovery Time	t _{rr}	T _J =25°C, I _F =I _S		30		nS
Reverse Recovery Charge	Q _{rr}	di/dt = 100A/μs ²⁾		125		nC

Notes:

- 1) Surface Mounted on FR4 Board, t ≤ 10 sec.
- 2) Pulse Test: Pulse Width ≤ 300μs, Duty Cycle ≤ 2%.
- 3) Guaranteed by design, not subject to production
- 4) EAS condition : T_J=25°C , V_{DD}=50V, V_G=10V, L=0.5mH, R_G=25Ω

Typical Characteristics

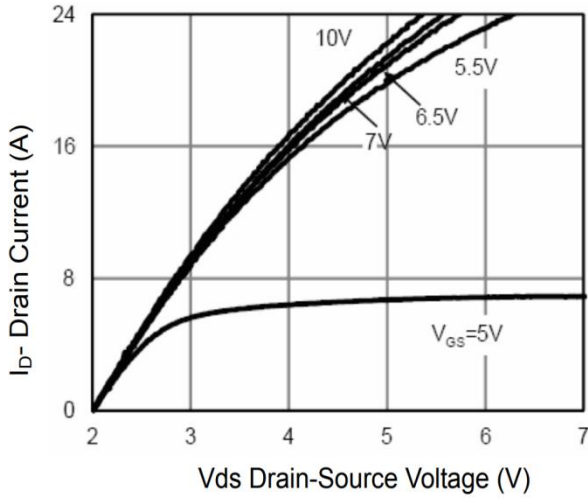

Figure 1 Output Characteristics

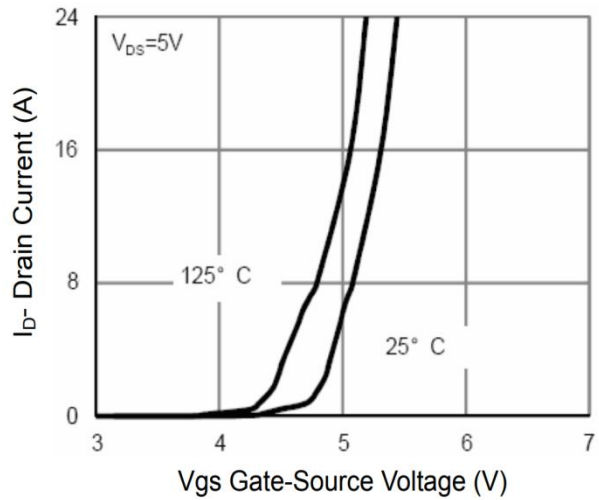

Figure 2 Transfer Characteristics

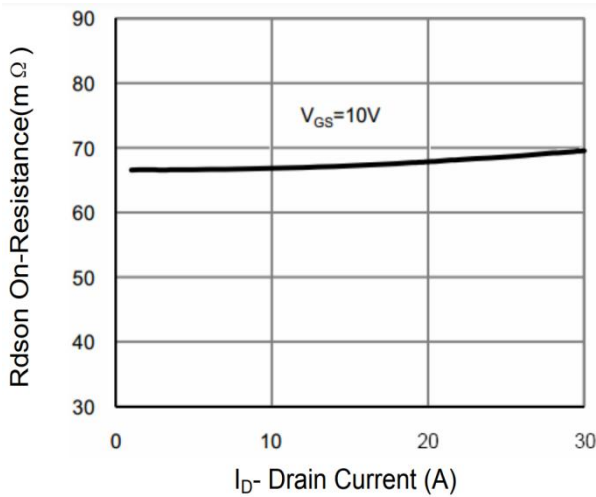

Figure 3 Rdson- Drain Current

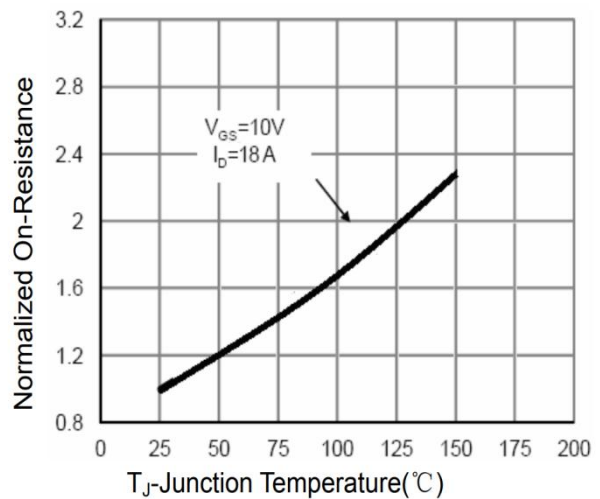

Figure 4 Rdson-Junction Temperature

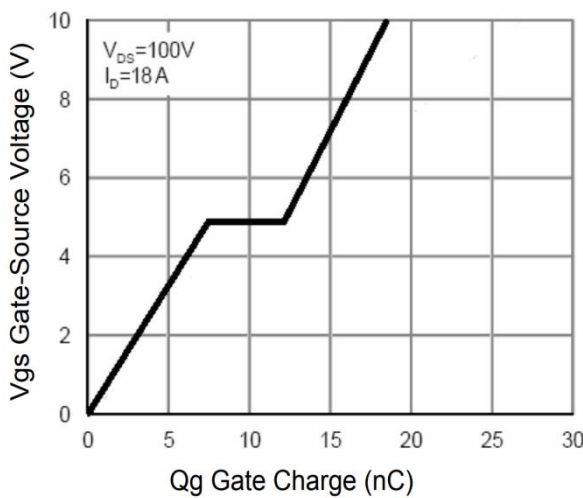

Figure 5 Gate Charge

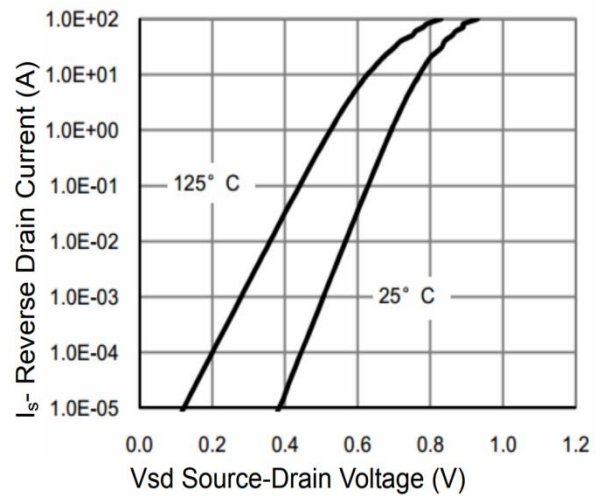

Figure 6 Source- Drain Diode Forward

Typical Characteristics

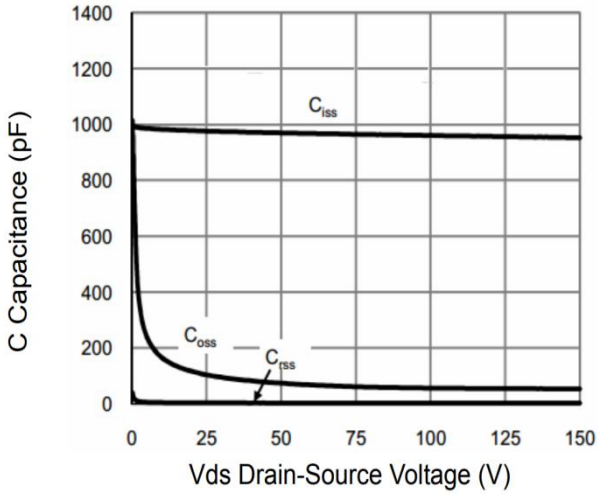

Figure 7 Capacitance vs Vds

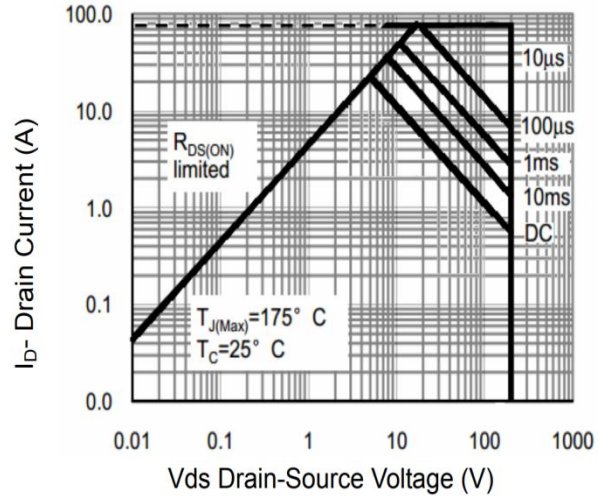

Figure 8 Safe Operation Area

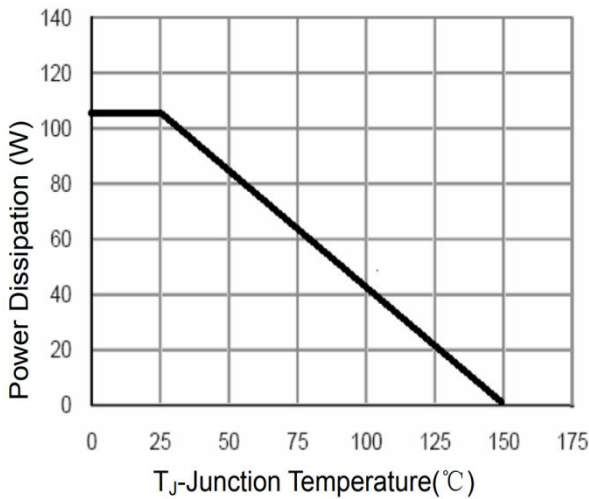

Figure 9 Power De-rating

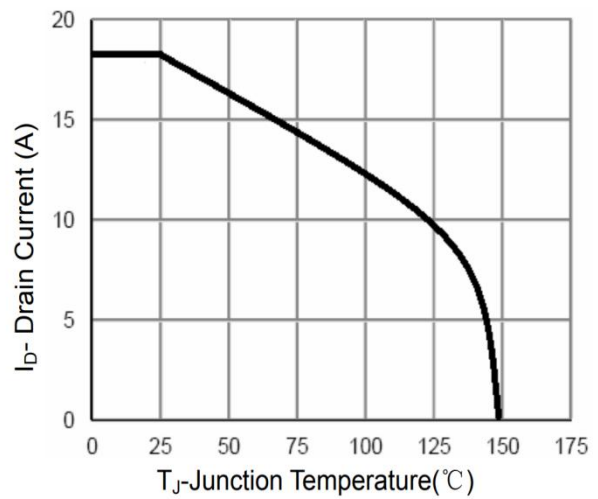

Figure 10 Current De-rating

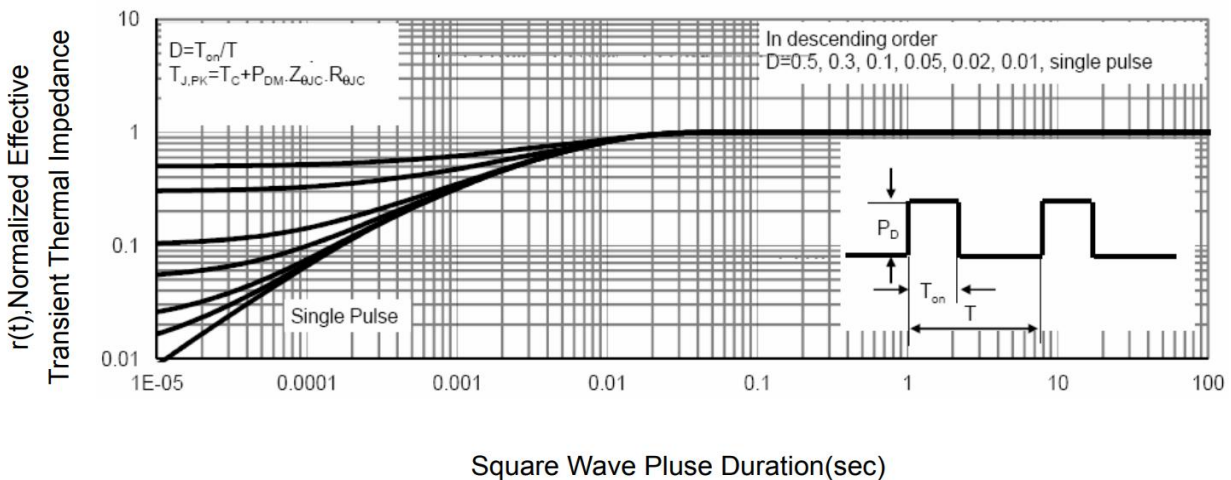
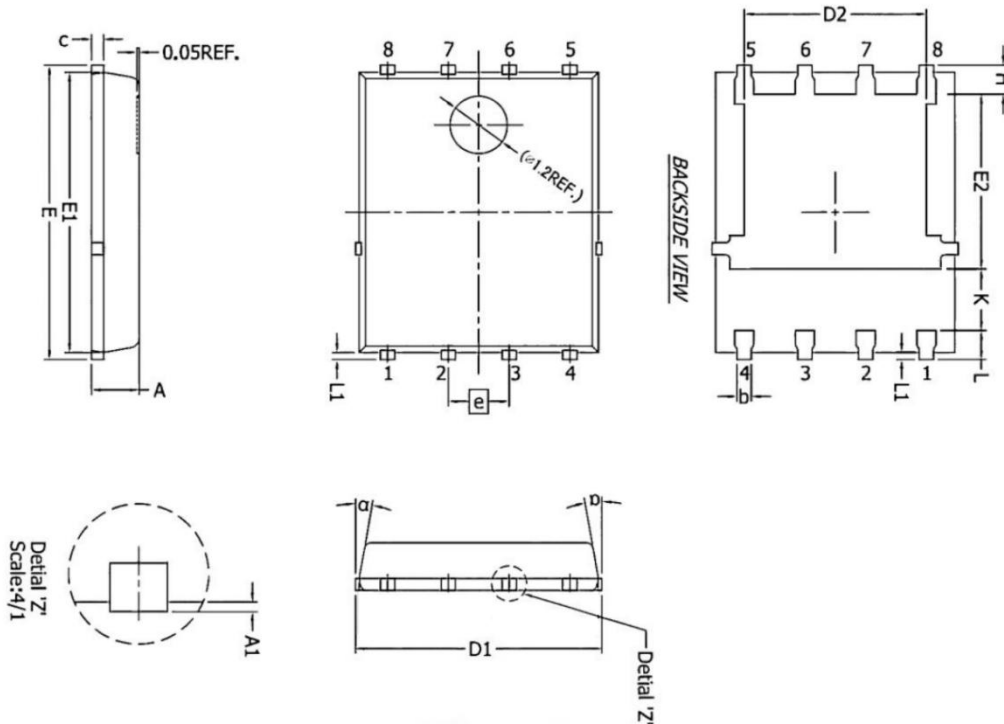

Figure 11 Normalized Maximum Transient Thermal Impedance

DFN5X6-8L Package Information



Symbol	Dimensions In Millimeters		Dimensions In Inches	
	Min.	Max.	Min.	Max.
A	0.900	1.100	0.035	0.043
A1	-	0.050	-	0.002
b	0.300	0.510	0.012	0.020
c	0.200	0.300	0.008	0.012
D1	4.900 BSC		0.193 BSC	
D2	3.610	3.960	0.142	0.156
E	6.000 BSC		0.236 BSC	
E1	5.700	5.800	0.224	0.228
E2	3.380	3.780	0.133	0.149
e	1.270 BSC		0.050 BSC	
H	0.410	0.610	0.016	0.024
K	1.100	-	0.043	-
L	0.510	0.710	0.020	0.028
L1	0.060	0.200	0.002	0.008
α	0°	12°	0°	12°