

Product Summary

$V_{(BR)DSS}$	$R_{DS(on)MAX}$	I_b
100V	5.0mΩ@10V	110A
	6.5mΩ@4.5V	

Feature

- Split gate trench MOSFET technology
- Excellent package for heat dissipation
- High density cell design for low $R_{ds(on)}$

Application

- Power switching application
- DC-DC converter
- Uninterruptible power supply

Package

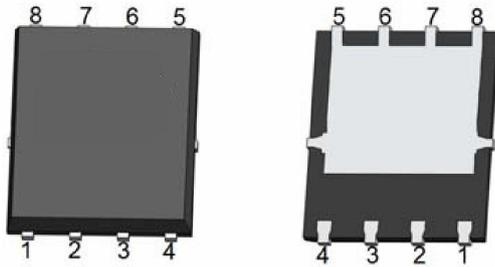

DFN5X6-8L

Circuit diagram

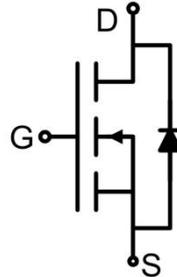

Marking

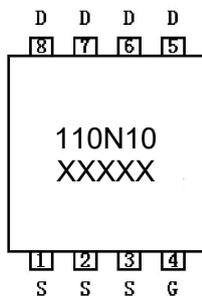

Absolute maximum ratings (T_A=25°C unless otherwise noted)

Parameter	Symbol	Value	Unit
Drain-Source Voltage	V _{DS}	100	V
Gate-Source Voltage	V _{GS}	±20	V
Continuous Drain Current	I _D	110	A
Drain Current-Continuous(T _C =100°C)	I _D (100°C)	70	A
Pulsed Drain Current ¹⁾	I _{DM}	440	A
Power Dissipation ²⁾	P _D	113	W
Thermal Resistance,Junction-to-Ambient ⁴⁾	R _{θJA}	53	°C/W
Thermal Resistance,Junction-to-Case	R _{θJC}	1.1	°C/W
Single pulse avalanche energy ³⁾	E _{AS}	400	mJ
Junction Temperature	T _J	150	°C
Storage Temperature	T _{STG}	-55 ~ +150	°C

Electrical characteristics (T_J=25°C unless otherwise noted)

Parameter	Symbol	Test Condition	Min.	Typ.	Max.	Unit
Static Characteristics						
Drain-source breakdown voltage	V _{(BR)DSS}	V _{GS} = 0V, I _D =250μA	100			V
Zero gate voltage drain current	I _{DSS}	V _{DS} =100V, V _{GS} = 0V			1	μA
Gate-body leakage current	I _{GSS}	V _{GS} =±20V, V _{DS} = 0V			±100	nA
Gate threshold voltage	V _{GS(th)}	V _{DS} =V _{GS} , I _D =250μA	1.0	1.7	2.5	V
Drain-source on-resistance	R _{DS(on)}	V _{GS} =10V, I _D =20A		3.8	5.0	mΩ
		V _{GS} =4.5V, I _D =20A		4.8	6.5	
Dynamic characteristics						
Input Capacitance	C _{iss}	V _{DS} =50V, V _{GS} =0V, f =1MHz		4300		pF
Output Capacitance	C _{oss}			1800		
Reverse Transfer Capacitance	C _{rss}			30		
Total Gate Charge	Q _g	V _{DS} =50V, V _{GS} =10V, I _D =55A		50		nC
Gate-Source Charge	Q _{gs}			4.5		
Gate-Drain Charge	Q _{gd}			7		
Turn-on delay time	t _{d(on)}	V _{DD} =50V, V _{GS} =10V, I _D =55A, R _{GEN} =2.2Ω		22		nS
Turn-on rise time	t _r			110		
Turn-off delay time	t _{d(off)}			38		
Turn-off fall time	t _f			8		
Source-Drain Diode characteristics						
Diode Forward Current	I _S				110	A
Diode Forward voltage	V _{DS}	V _{GS} =0V, I _S =55A			1.2	V
Reverse Recovery Time	t _{rr}	T _J = 25°C, I _F =55A		48		nS
Reverse Recovery Charge	Q _{rr}	di/dt = 100A/μs		150		nC

Notes:

- 1) Repetitive rating; pulse width limited by max. junction temperature.
- 2) P_d is based on max. junction temperature, using junction-case thermal resistance.
- 3) EAS condition : T_J=25°C, V_{DD}=50V, V_{GS}=10V, R_G=2.5Ω, L=2mH I_{AS}=20A
- 4) The value of R_{θJA} is measured with the device mounted on 1in2 FR-4 board with 2oz. Copper, in a still air environment with T_A=25°C.

Typical Characteristics

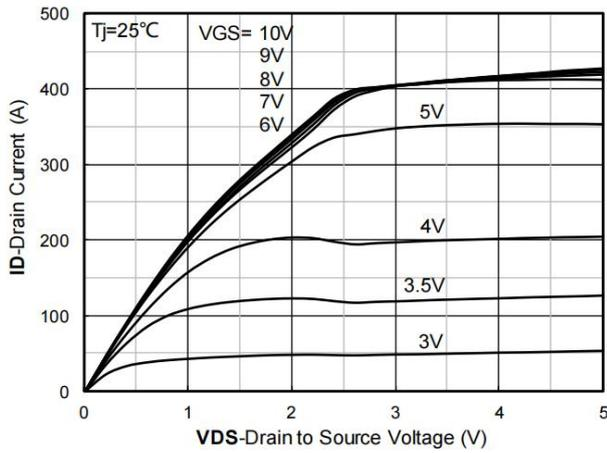

Figure 1. Output Characteristics

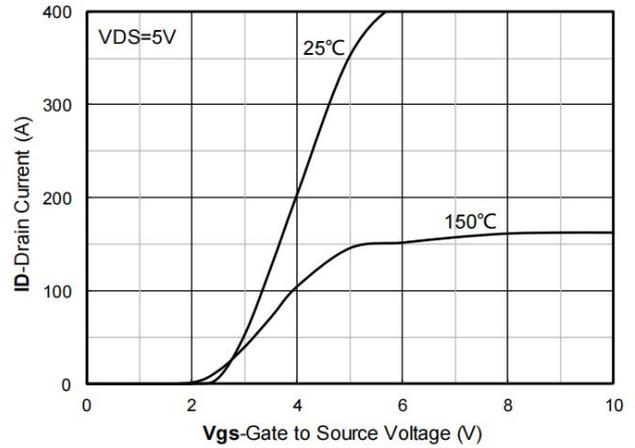

Figure 2. Transfer Characteristics

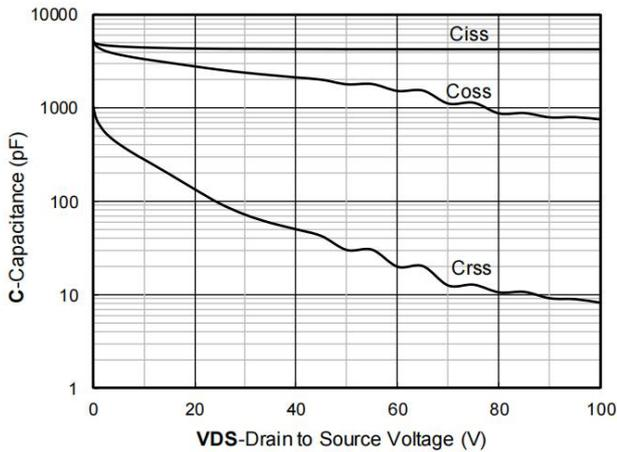

Figure 3. Capacitance Characteristics

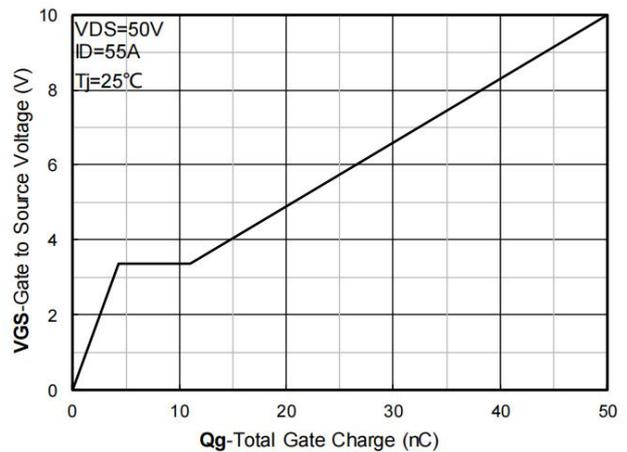

Figure 4. Gate Charge

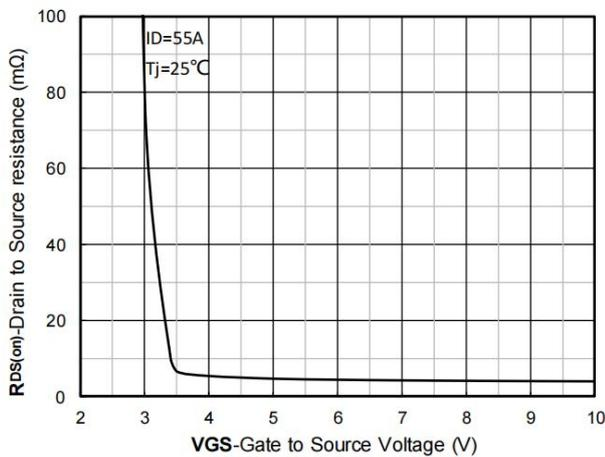

Figure 5. On-Resistance vs Gate to Source Voltage

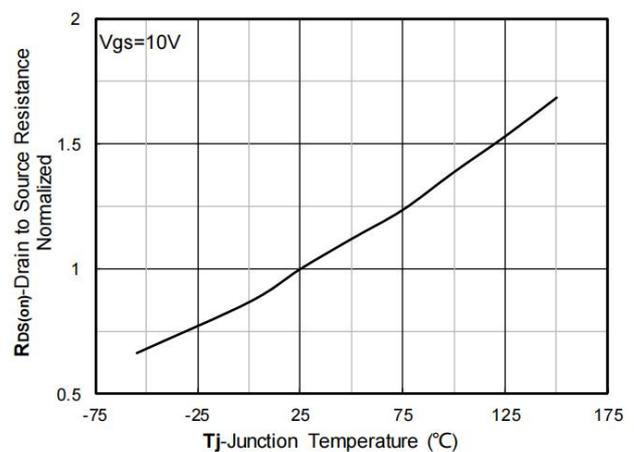

Figure 6. Normalized On-Resistance

Typical Characteristics

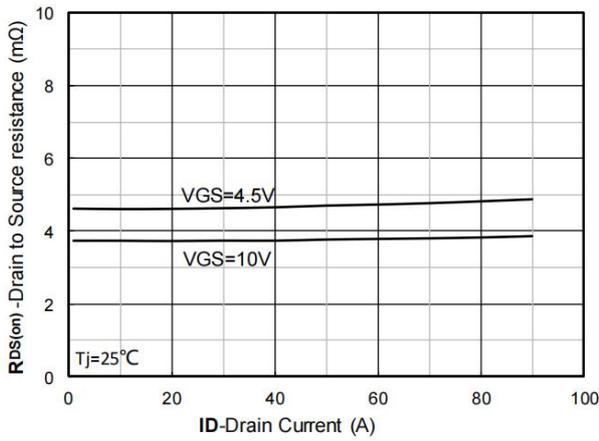

Figure 7. $R_{DS(on)}$ VS Drain Current

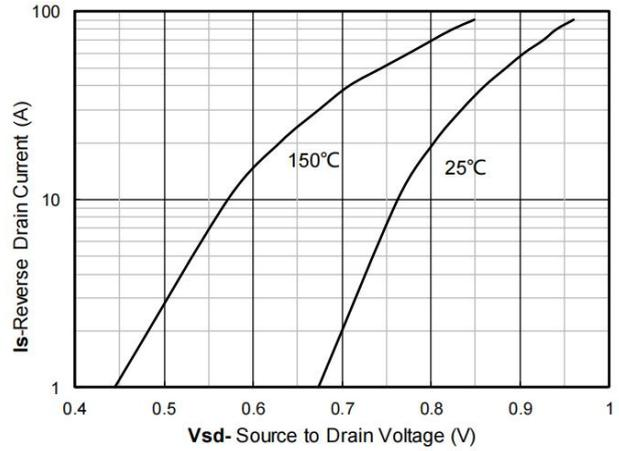

Figure 8. Forward characteristics of reverse diode

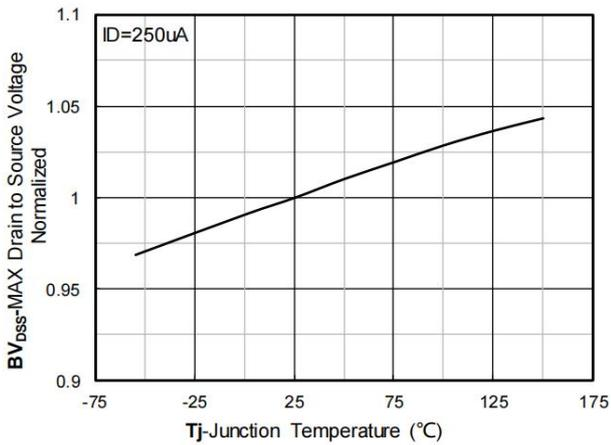

Figure 9. Normalized breakdown voltage

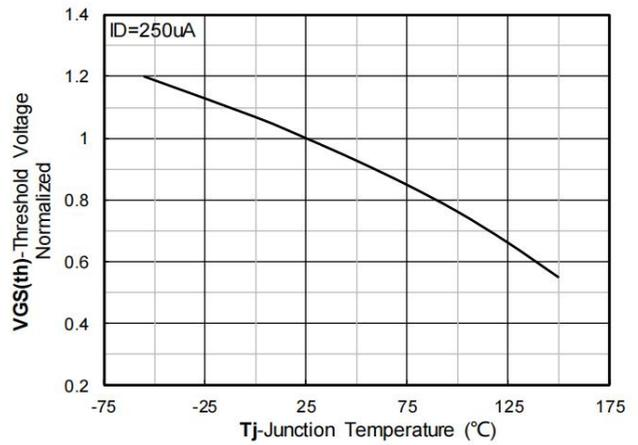

Figure 10. Normalized Threshold voltage

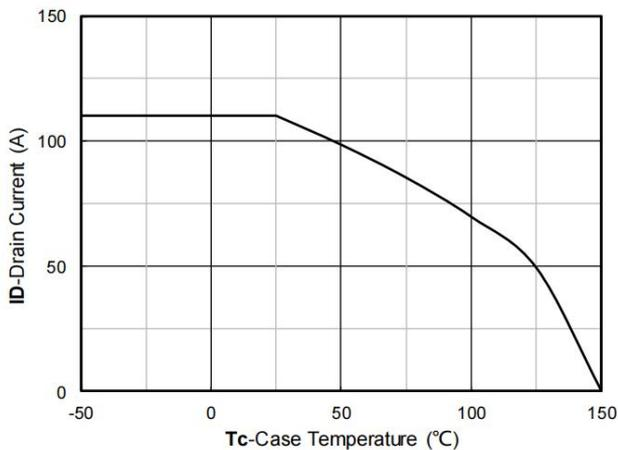

Figure 11. Current dissipation

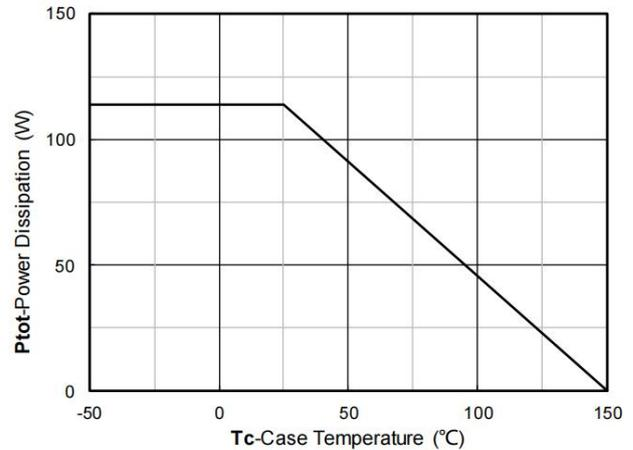

Figure 12. Power dissipation

Typical Characteristics

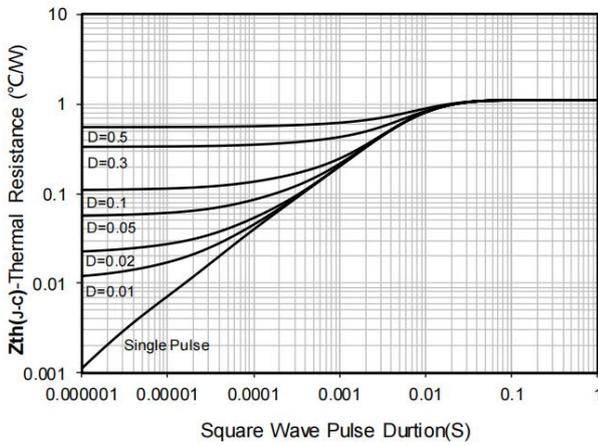

Figure 13. Maximum Transient Thermal Impedance

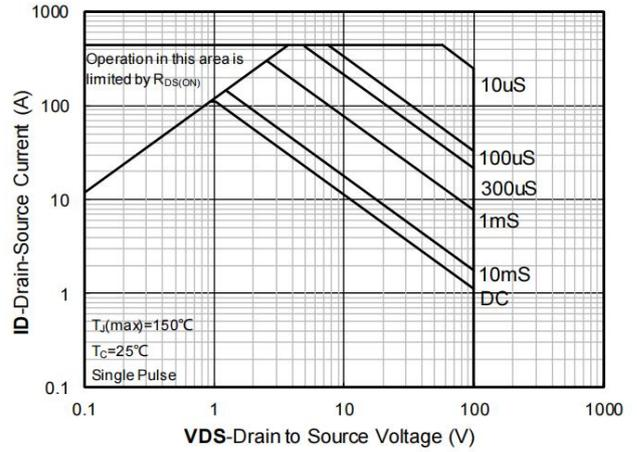
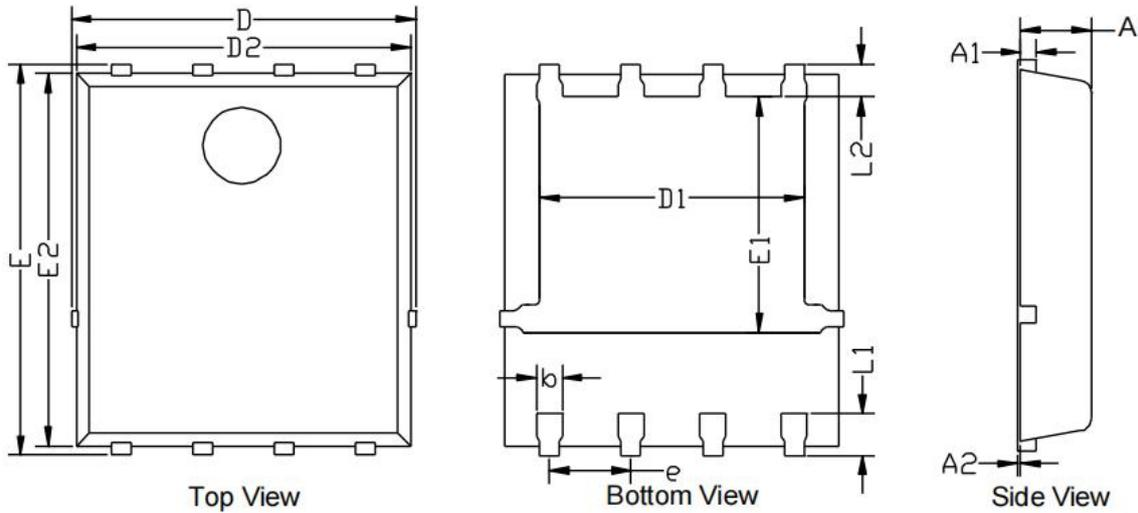

Figure 14. Safe Operation Area

DFN5X6-8L Package Information



Symbol	Dimensions In Millimeters		Dimensions In Inches	
	Min.	Max.	Min.	Max.
A	1.000	1.200	0.039	0.047
A1	0.254BSC.		0.010BSC.	
A2	0.000	0.100		0.004
D	5.150	5.550	0.202	0.219
E	5.950	6.350	0.234	0.250
D1	3.920	4.320	0.154	0.170
E1	3.520	3.920	0.139	0.154
D2	5.000	5.400	0.197	0.212
E2	5.660	6.060	0.223	0.239
b	0.310	0.510	0.012	0.020
e	1.270BSC.		0.050BSC	
L1	0.560	0.760	0.022	0.030
L2	0.500BSC.		0.020BSC	