

### Product Summary

$V_{(BR)DSS}$	$R_{DS(on)MAX}$	$I_D$
30V	5mΩ@10V	65A
	8mΩ@4.5V	

### Feature

- Trench Power LV MOSFET technology
- Excellent package for heat dissipation
- High density cell design for low  $R_{DS(ON)}$
- Epoxy Meets UL 94 V-0 Flammability Rating

### Application

- High current load applications
- Load switching
- Hard switched and high frequency circuits
- Uninterruptible power supply

### Package

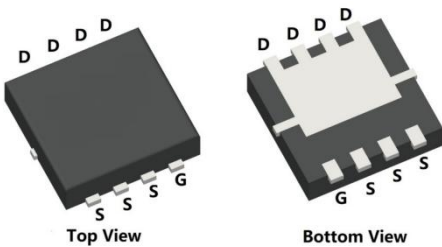

PDFN3.3X3.3-8L

### Circuit diagram

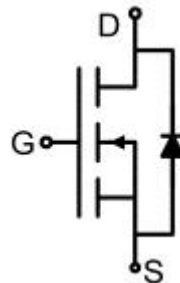

### Marking

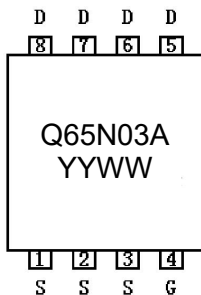

### Absolute maximum ratings (T<sub>A</sub>=25°C unless otherwise noted)

Parameter	Symbol	Value	Unit
Drain-Source Voltage	V <sub>DS</sub>	30	V
Gate-Source Voltage	V <sub>GS</sub>	±20	V
Continuous Drain Current(T <sub>C</sub> =25°C )	I <sub>D</sub>	65	A
Continuous Drain Current(T <sub>C</sub> =100°C )	I <sub>D</sub> (100 °C)	41	A
Pulsed Drain Current <sup>1)</sup>	I <sub>DM</sub>	200	A
Power Dissipation <sup>3)</sup>	P <sub>D</sub>	2	W
Single pulse avalanche energy <sup>2)</sup>	E <sub>AS</sub>	112	mJ
Thermal Resistance,Junction-to-Case	R <sub>θJC</sub>	2.5	°C/W
Junction Temperature	T <sub>J</sub>	150	°C
Storage Temperature	T <sub>STG</sub>	-55 ~ +150	°C

### Electrical characteristics (T<sub>J</sub>=25°C unless otherwise noted)

Parameter	Symbol	Test Condition	Min.	Typ.	Max.	Unit
<b>Static Characteristics</b>						
Drain-source breakdown voltage	V <sub>(BR)DSS</sub>	V <sub>GS</sub> = 0V, I <sub>D</sub> =250μA	30			V
Zero gate voltage drain current	I <sub>DSS</sub>	V <sub>DS</sub> =30V,V <sub>GS</sub> = 0V			1	μA
Gate-body leakage current	I <sub>GSS</sub>	V <sub>GS</sub> =±20V, V <sub>DS</sub> = 0V			±100	nA
Gate threshold voltage	V <sub>GS(th)</sub>	V <sub>DS</sub> =V <sub>GS</sub> , I <sub>D</sub> =250μA	1.0	1.5	2.5	V
Drain-source on-resistance	R <sub>DS(on)</sub>	V <sub>GS</sub> =10V, I <sub>D</sub> =32.5A		3.7	5	mΩ
		V <sub>GS</sub> =10V, I <sub>D</sub> =20A		3.7	5	
		V <sub>GS</sub> =4.5V, I <sub>D</sub> =15A		6	8	
<b>Dynamic characteristics<sup>4)</sup></b>						
Input Capacitance	C <sub>iss</sub>	V <sub>DS</sub> =15V,V <sub>GS</sub> =0V,f =1MHz		1790		pF
Output Capacitance	C <sub>oss</sub>			300		
Reverse Transfer Capacitance	C <sub>rss</sub>			280		
Total Gate Charge	Q <sub>g</sub>	V <sub>DS</sub> =15V,V <sub>GS</sub> =10V, I <sub>D</sub> =32.5A		38		nC
Gate-Source Charge	Q <sub>gs</sub>			7		
Gate-Drain Charge	Q <sub>gd</sub>			12		
Turn-on delay time	t <sub>d(on)</sub>	V <sub>DD</sub> =15V,V <sub>GS</sub> =10V, I <sub>D</sub> =32.5A,R <sub>GEN</sub> =2.2Ω		9		nS
Turn-on rise time	t <sub>r</sub>			242		
Turn-off delay time	t <sub>d(off)</sub>			24		
Turn-off fall time	t <sub>f</sub>			17		
<b>Source-Drain Diode characteristics</b>						
Diode Forward Current	I <sub>S</sub>				65	A
Diode Forward voltage	V <sub>SD</sub>	V <sub>GS</sub> =0V, I <sub>S</sub> =32.5A			1.2	V
Reverse Recovery Time	t <sub>rr</sub>	I <sub>F</sub> = 32.5A, di/dt = 120A/μs		16		nS
Reverse Recovery Charge	Q <sub>rr</sub>			7		nC

Notes:

- 1) Repetitive rating; pulse width limited by max. junction temperature.
- 2) T<sub>J</sub>=25°C, V<sub>DD</sub>=25V, V<sub>G</sub>=10V, R<sub>G</sub>=25Ω, L=1mH, I<sub>AS</sub>=15A.
- 3) P<sub>d</sub> is based on max. junction temperature, using junction-case thermal resistance.
- 4) Guaranteed by design, not subject to production.

## Typical Characteristics

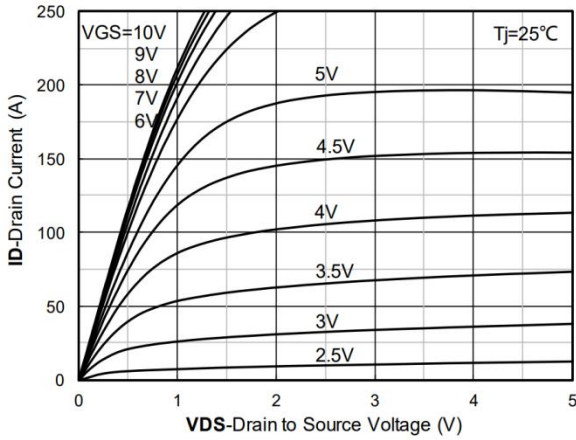

Figure 1. Output Characteristics

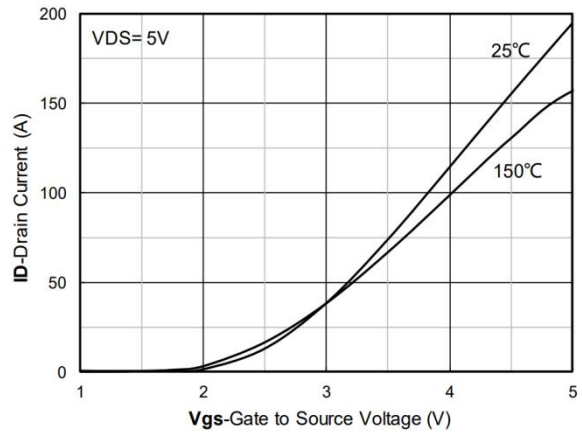

Figure 2. Transfer Characteristics

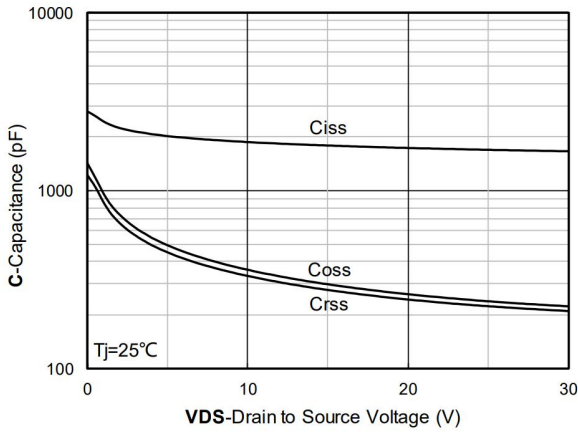

Figure 3. Capacitance Characteristics

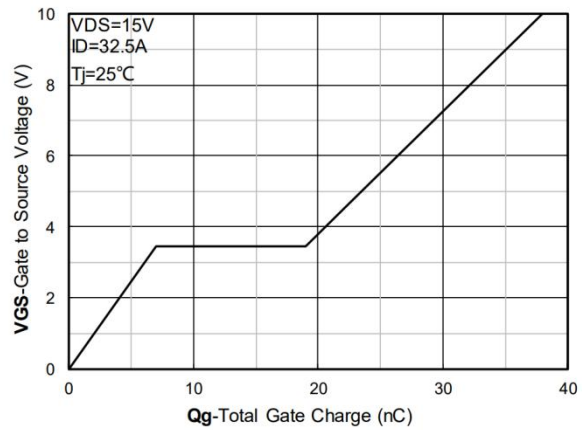

Figure 4. Gate Charge

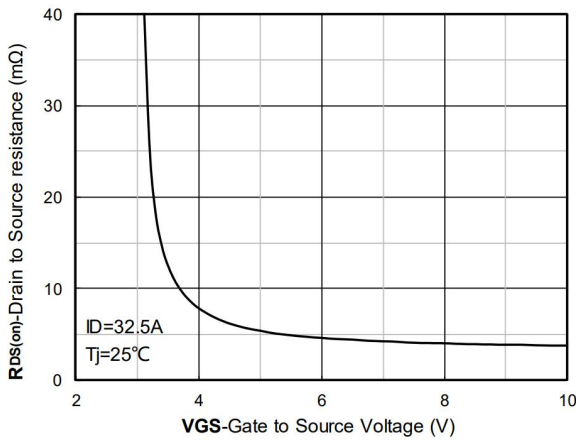

Figure 5. On-Resistance vs Gate to Source Voltage

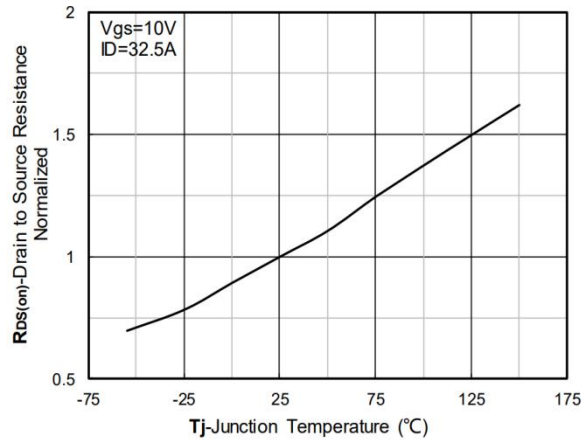

Figure 6. Normalized On-Resistance

## Typical Characteristics

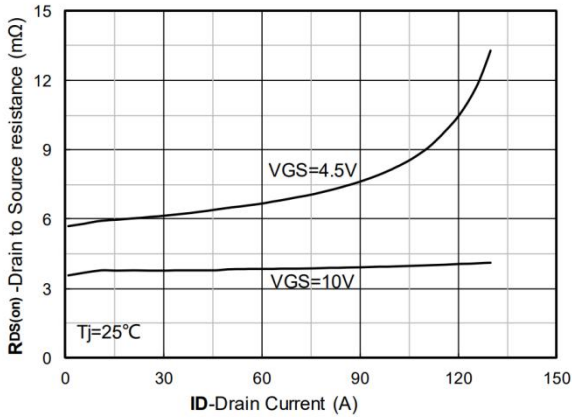

Figure 7. RDS(on) VS Drain Current

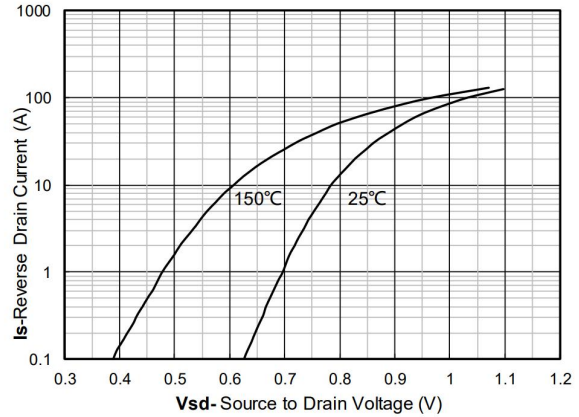

Figure 8. Forward characteristics of reverse diode

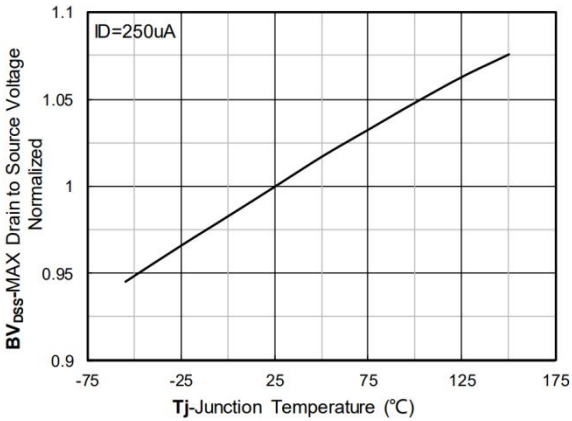

Figure 9. Normalized breakdown voltage

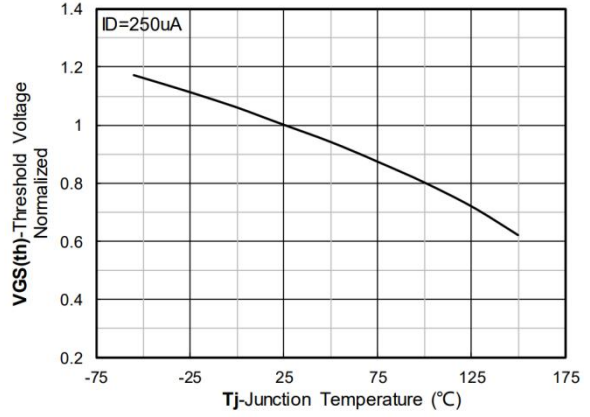

Figure 10. Normalized Threshold voltage

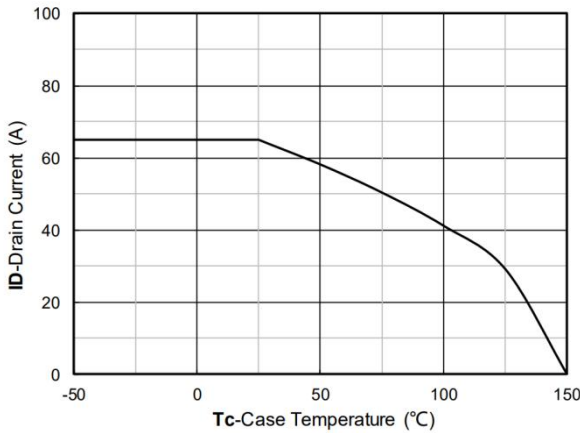

Figure 11. Current dissipation

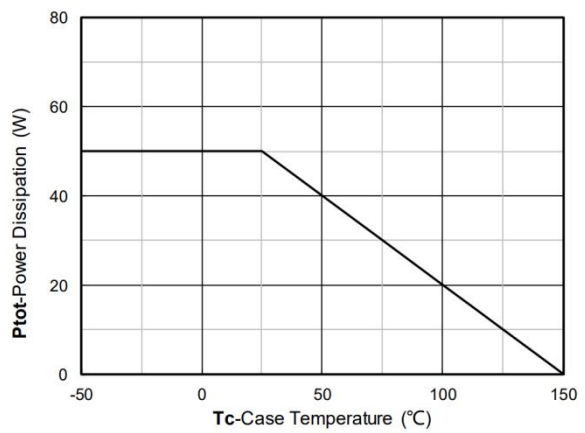

Figure 12. Power dissipation

## Typical Characteristics

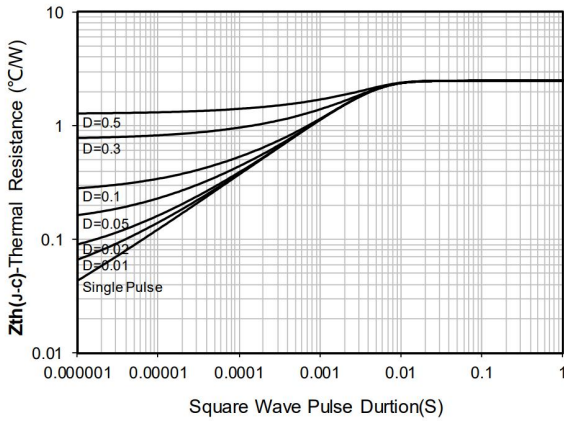

Figure 13. Maximum Transient Thermal Impedance

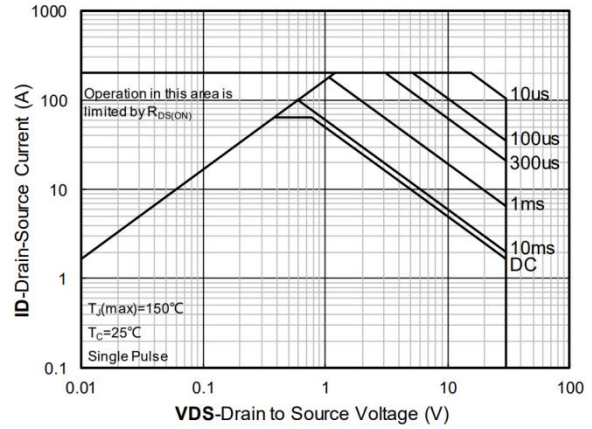
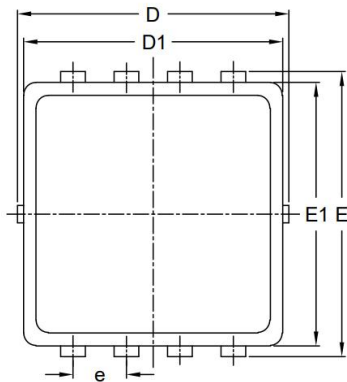
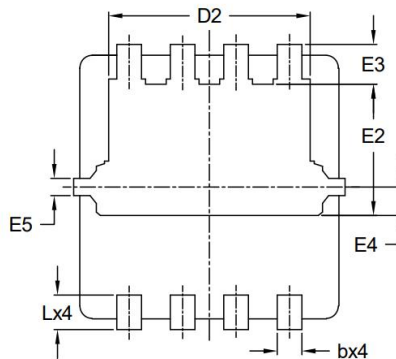

Figure 14. Safe Operation Area

### PDFN3.3X3.3-8L Package Information



TOP VIEW



BOTTOM VIEW

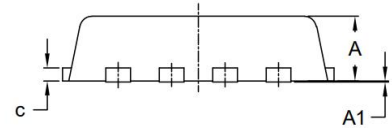

SIDE VIEW

Symbol	Dimensions In Millimeters		Dimensions In Inches	
	Min.	Max.	Min.	Max.
A	0.700	0.850	0.028	0.033
A1	0.000	0.050	0.000	0.002
b	0.200	0.400	0.008	0.016
c	0.100	0.250	0.004	0.010
D	3.150	3.450	0.124	0.136
D1	3.000	3.300	0.118	0.130
D2	2.250	2.650	0.089	0.104
E	3.150	3.450	0.124	0.136
E1	2.900	3.200	0.114	0.126
E2	1.320	1.720	0.052	0.068
E3	0.280	0.650	0.011	0.026
E4	0.330 REF		0.013 REF	
E5	0.200 REF		0.008 REF	
e	0.650 BSC		0.026 BSC	
L	0.300	0.500	0.012	0.020