

Product Summary

$V_{(BR)DSS}$	$R_{DS(on)MAX}$	I_D
100V	3.9mΩ@10V	135A

Feature

- Excellent gate charge x $R_{DS(on)}$ product(FOM)
- Very low on-resistance $R_{DS(on)}$
- Suffix“-Q1”for AEC-Q101

Application

- DC/DC Converter
- Ideal for high-frequency switching and synchronous rectification

Package



TO-263AB

Circuit diagram

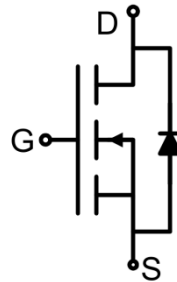

Marking

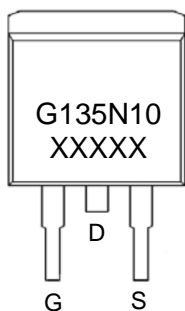

Absolute Maximum Ratings (T_c=25°C unless otherwise noted)

Parameter	Symbol	Value	Unit
Drain-Source Voltage	V _{DS}	100	V
Gate-Source Voltage	V _{GS}	±20	V
Continuous Drain Current	I _D	135	A
Continuous Drain Current(T _C =100°C)	I _D (100°C)	108	A
Pulsed Drain Current	I _{DM}	540	A
Power Dissipation	P _D	220	W
Thermal Resistance,Junction-to-Case	R _{θJC}	0.68	°C/W
Single pulse avalanche energy ¹⁾	E _{AS}	730	mJ
Junction Temperature	T _J	150	°C
Storage Temperature	T _{STG}	-55 ~ +150	°C

Electrical characteristics (T_c=25 °C unless otherwise noted)

Parameter	Symbol	Test Condition	Min.	Typ.	Max.	Unit
Static Characteristics						
Drain-source breakdown voltage	V _{(BR)DSS}	V _{GS} = 0V, I _D =250μA	100			V
Zero gate voltage drain current	I _{DSS}	V _{DS} =100V, V _{GS} = 0V			1	μA
Gate-body leakage current	I _{GSS}	V _{GS} =±20V, V _{DS} = 0V			±100	nA
Gate threshold voltage	V _{GS(th)}	V _{DS} =V _{GS} , I _D =250μA	2	3	4	V
Drain-source on-resistance	R _{DS(on)}	V _{GS} =10V, I _D =65A		3.5	3.9	mΩ
Dynamic characteristics²⁾						
Input Capacitance	C _{iss}	V _{DS} =50V, V _{GS} =0V, f =1MHz		9500		pF
Output Capacitance	C _{oss}			650		
Reverse Transfer Capacitance	C _{rss}			40		
Total Gate Charge	Q _g	V _{DS} =50V, V _{GS} =10V, I _D =65A		125		nC
Gate-Source Charge	Q _{gs}			40.5		
Gate-Drain Charge	Q _{gd}			33		
Turn-on delay time	t _{d(on)}	V _{DD} =50V, V _{GS} =10V, I _D =65A, R _G =1.6Ω		20		nS
Turn-on rise time	t _r			11.5		
Turn-off delay time	t _{d(off)}			48		
Turn-off fall time	t _f			10		
Source-Drain Diode characteristics						
Diode Forward Current	I _S				135	A
Diode Forward voltage	V _{SD}	V _{GS} =0V, I _S =65A			1.2	V
Reverse Recovery Time	t _{rr}	T _J = 25°C, I _F =I _S di/dt = 100A/μs		76		nS
Reverse Recovery Charge	Q _{rr}			150		nC

Notes:

1) EAS condition : T_J=25°C, V_{DD}=50V, V_G=10V, L=0.5mH, R_G=25Ω.

2) Guaranteed by design, not subject to production testing.

Typical Characteristics

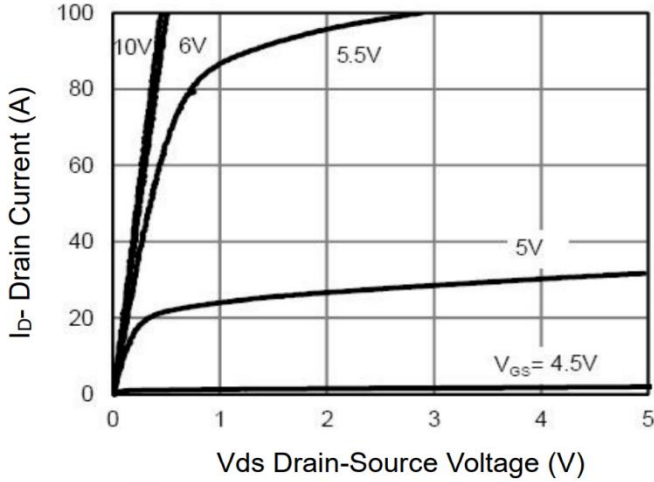

Figure 1 Output Characteristics

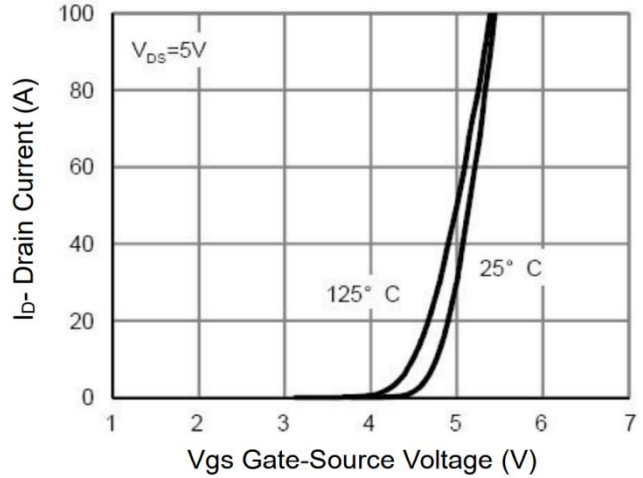

Figure 2 Transfer Characteristics

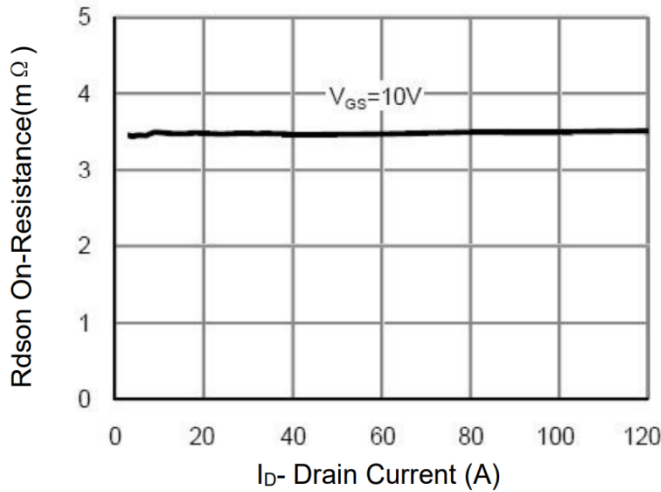

Figure 3 Rdson- Drain Current

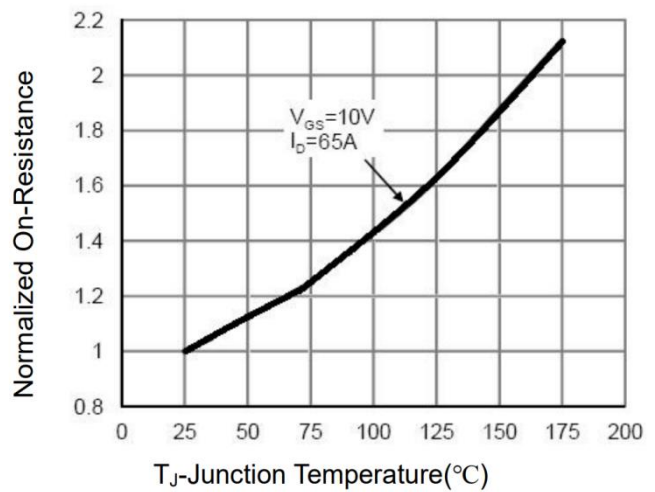

Figure 4 Rdson-Junction Temperature

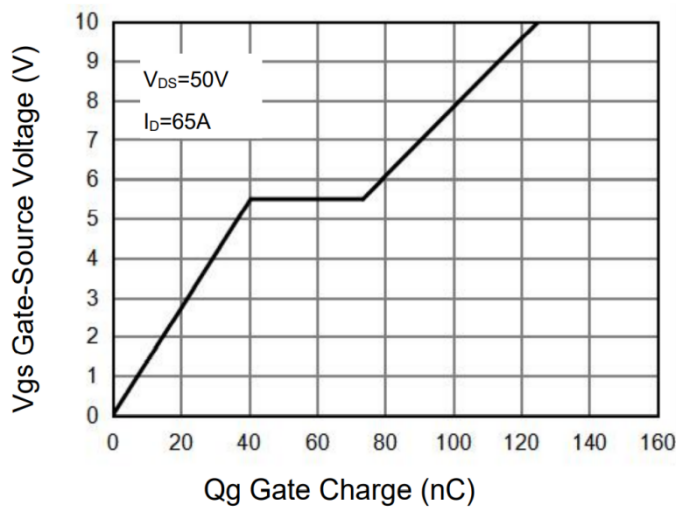

Figure 5 Gate Charge

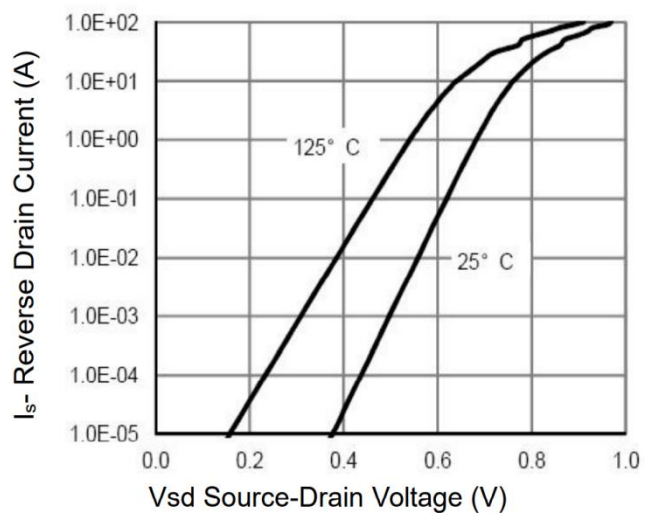

Figure 6 Source- Drain Diode Forward

Typical Characteristics

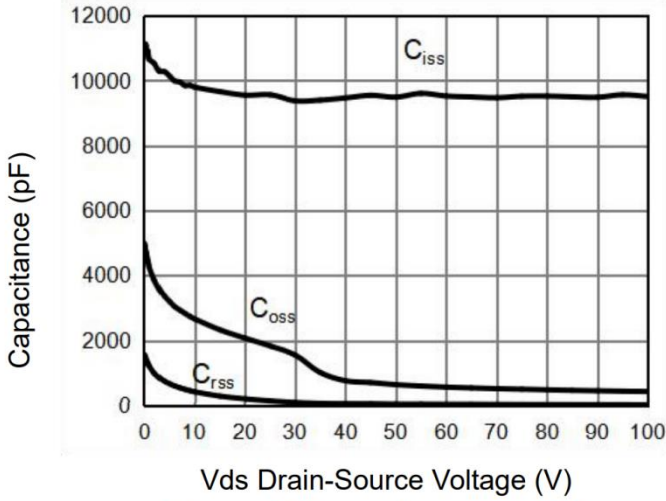

Figure 7 Capacitance vs Vds

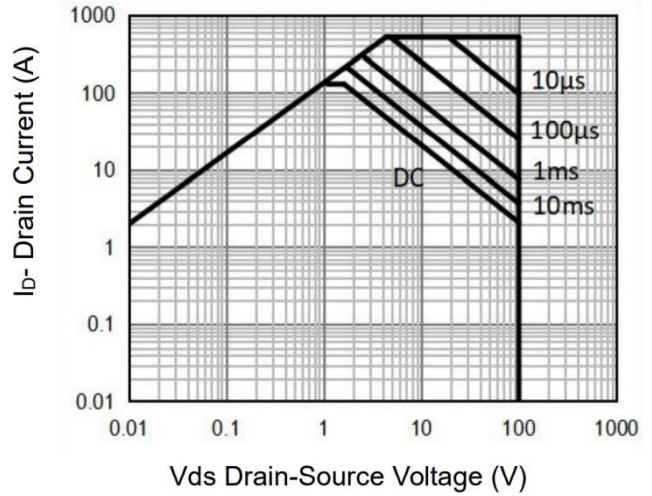

Figure 8 Safe Operation Area (Note 3)

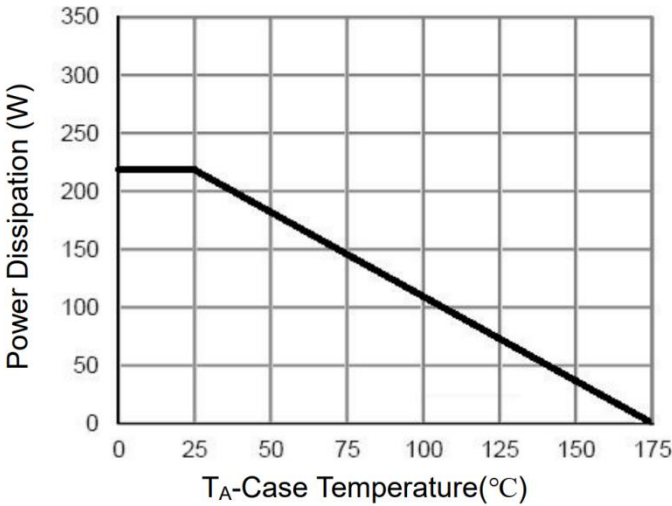

Figure 9 Power De-rating

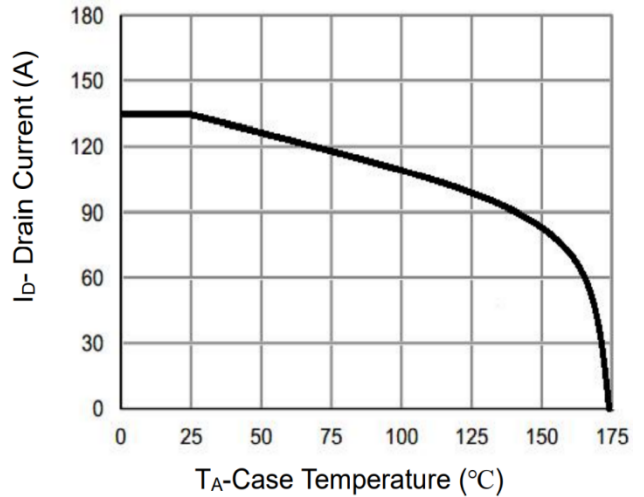

Figure 10 Current De-rating

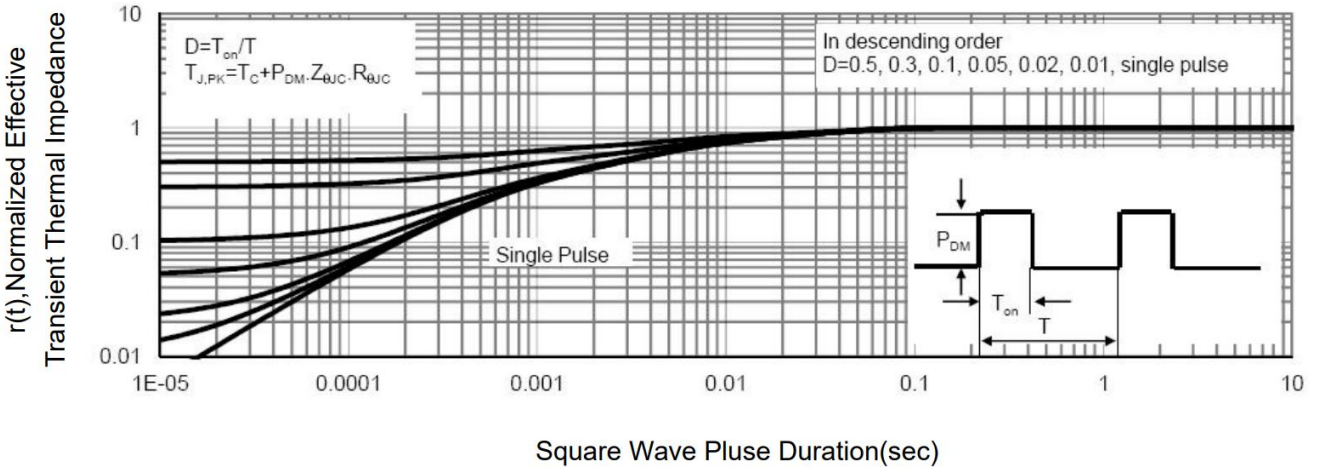
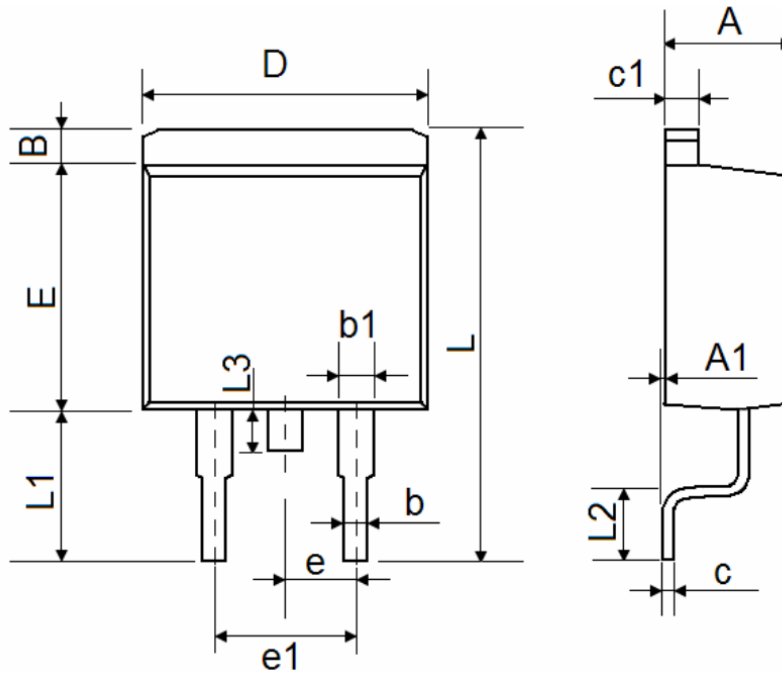

Figure 11 Normalized Maximum Transient Thermal Impedance

TO-263AB Package Information



Symbol	Dimensions In Millimeters		Dimensions In Inches	
	Min.	Max.	Min.	Max.
A	4.200	4.670	0.165	0.184
A1	0.000	0.250	0.000	0.010
B	1.360 REF.		0.054 REF.	
b	0.700	0.910	0.028	0.036
b1	1.170	1.750	0.046	0.069
c	0.310	0.600	0.012	0.024
c1	1.150	1.400	0.045	0.055
D	9.960	10.360	0.392	0.408
E	8.500	9.300	0.335	0.366
e	2.540 BSC.		0.100 BSC.	
e1	5.080 BSC.		0.200 BSC.	
L	14.610	15.880	0.575	0.625
L1	4.400	6.000	0.173	0.236
L2	1.780	2.790	0.070	0.110
L3	1.500 REF.		0.059 REF.	