

Product Summary

$V_{(BR)DSS}$	$R_{DS(on)MAX}$	I_D
200V	9.5mΩ@10V	108A

Feature

- LOW $R_{DS(on)}$
- High speed switch

Application

- Power tools
- LED lighting

Package

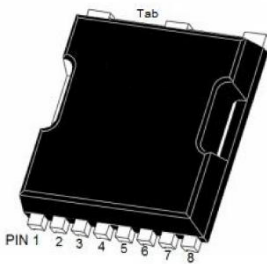

TOLL

Circuit diagram

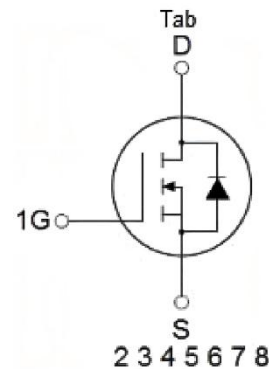

Marking

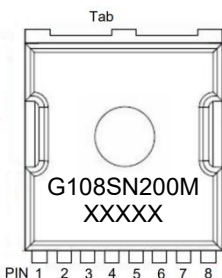

Absolute maximum ratings ($T_A=25^\circ\text{C}$ unless otherwise noted)

Parameter	Symbol	Value	Unit
Drain-Source Voltage	V_{DS}	200	V
Gate-Source Voltage	V_{GS}	± 20	V
Continuous Drain Current ($T_C=25^\circ\text{C}$)	I_D	108	A
Continuous Drain Current ($T_C=100^\circ\text{C}$)	$I_{D(100^\circ\text{C})}$	76	A
Pulsed Drain Current ¹⁾	I_{DM}	450	A
Single Pulse Avalanche Energy ²⁾	E_{AS}	1003.5	mJ
Power Dissipation ($T_C=25^\circ\text{C}$)	P_D	230	W
Thermal Resistance Junction to Case	$R_{\theta JC}$	0.65	$^\circ\text{C/W}$
Operating Junction Temperature	T_J	-55 ~ +175	$^\circ\text{C}$
Storage Temperature Range	T_{STG}	-55 ~ +175	$^\circ\text{C}$

Electrical characteristics ($T_A=25^\circ\text{C}$ unless otherwise noted)

Parameter	Symbol	Test Condition	Min.	Typ.	Max.	Unit
Static Characteristics						
Drain-source breakdown voltage	$V_{(BR)DSS}$	$V_{GS} = 0V, I_D = 250\mu\text{A}$	200			V
Zero gate voltage drain current	I_{DSS}	$V_{DS} = 160V, V_{GS} = 0V$			1	μA
Gate-body leakage current	I_{GSS}	$V_{DS} = 0V, V_{GS} = \pm 16V$			± 100	nA
Gate threshold voltage	$V_{GS(th)}$	$V_{DS} = V_{GS}, I_D = 250\mu\text{A}$	2	2.9	4	V
Drain-source on-resistance	$R_{DS(on)}$	$V_{GS} = 10V, I_D = 20A$		6.5	9.5	m Ω
Dynamic characteristics³⁾						
Input Capacitance	C_{iss}	$V_{DS} = 100V, V_{GS} = 0V, f = 1\text{MHz}$		9294		pF
Output Capacitance	C_{oss}			488		
Reverse Transfer Capacitance	C_{rss}			26		
Total Gate Charge	Q_g	$V_{DS} = 100V, V_{GS} = 10V, I_D = 20A$		148		nC
Gate-Source Charge	Q_{gs}			43		
Gate-Drain Charge	Q_{gd}			35		
Turn-on delay time	$t_{d(on)}$	$V_{DS} = 100V, V_{GS} = 10V, I_D = 20A$ $R_G = 3.3\Omega$		53		nS
Turn-on rise time	t_r			40		
Turn-off delay time	$t_{d(off)}$			46		
Turn-off fall time	t_f			17		
Source-Drain Diode characteristics						
Diode Forward Current	I_S				108	A
Diode Forward voltage	V_{SD}	$V_{GS} = 0V, I_S = 1A$			1.2	V
Reverse Recovery Time	T_{rr}	$I_F = 20A, di/dt = -200A/\mu\text{s}$		112		nS
Reverse Recovery Charge	Q_{rr}			900		nC

Notes:

1) Pulse Test: Pulse Width $\leq 100\mu\text{s}$, Duty Cycle $\leq 2\%$, Repetitive rating, pulse width limited by junction temperature $T_{J(MAX)} = 175^\circ\text{C}$.

2) Limited by $T_{J(MAX)}$, starting $T_J = 25^\circ\text{C}$, $L = 0.1\text{mH}$, $R_G = 25\Omega$, $I_{AS} = 44.8A$, $V_{GS} = 10V$.

3) Guaranteed by design, not subject to production.

Typical Characteristics

Fig. 1 Typical Output Characteristics

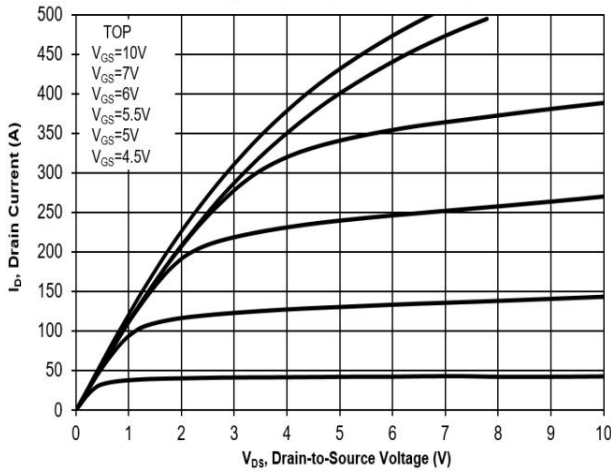

Fig. 2 Typical Transfer Characteristics

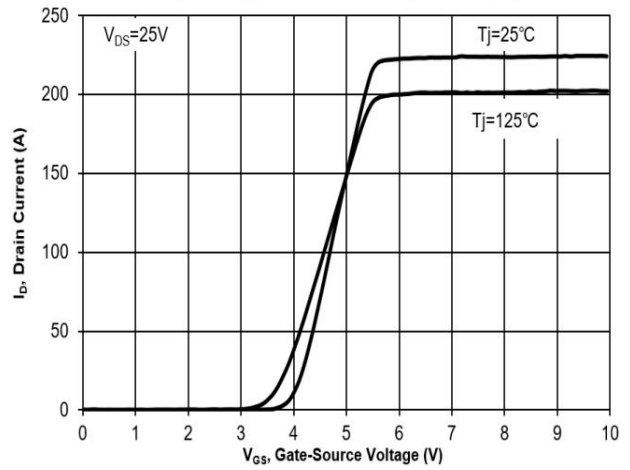

Fig. 3 On-Resistance vs. Drain Current

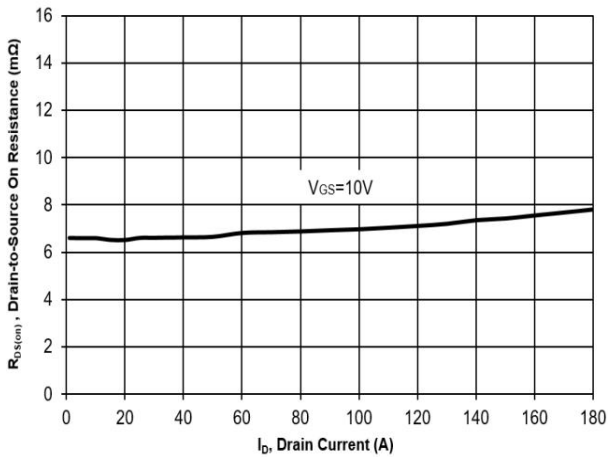

Fig. 4 On-Resistance vs. Gate to Source Voltage

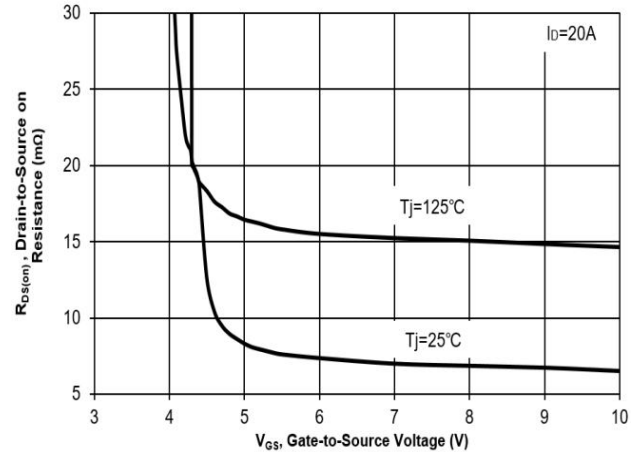

Fig. 5 On-Resistance vs. T_J

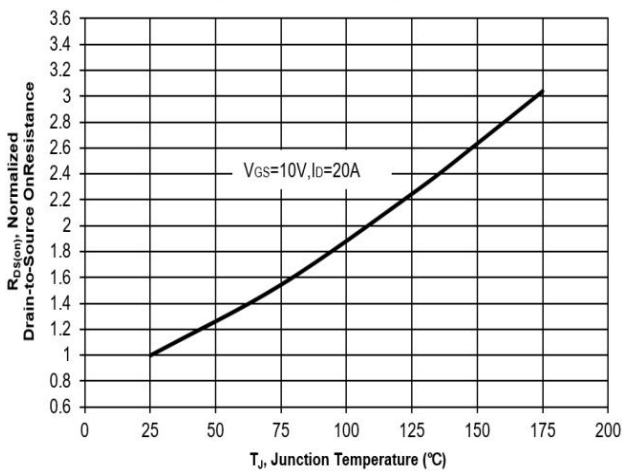
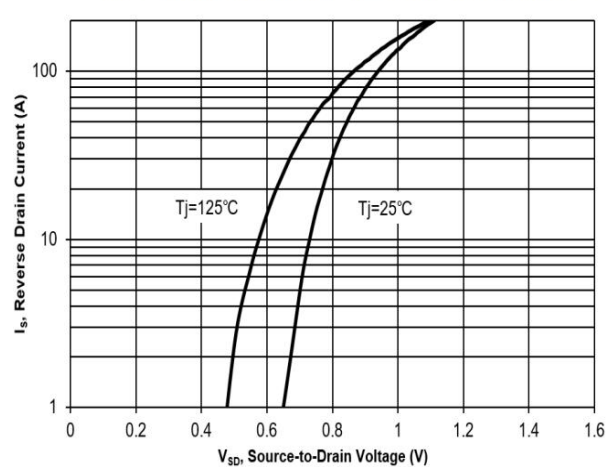

Fig. 6 Typical Body Diode Forward Characteristics



Typical Characteristics

Fig. 7 Typical Junction Capacitance

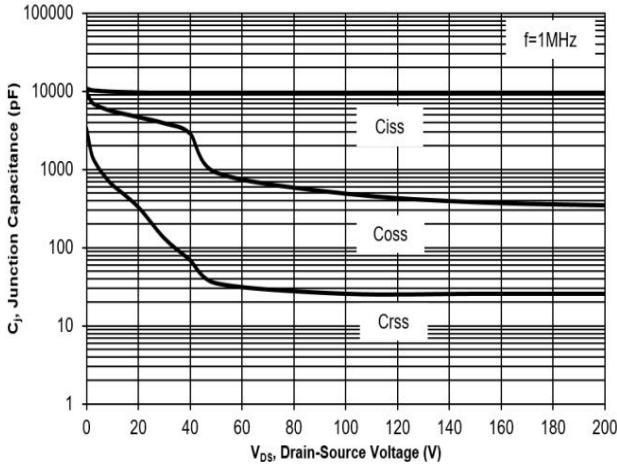

Fig. 8 Drain-Source Leakage Current vs. T_j

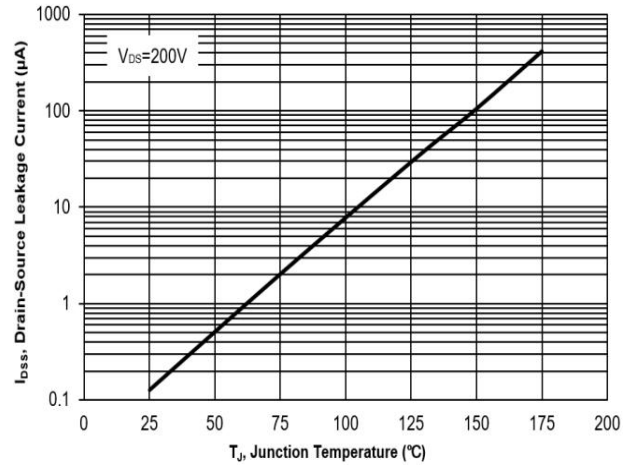

Fig. 9 $V_{(BR)DSS}$ vs. Junction Temperature

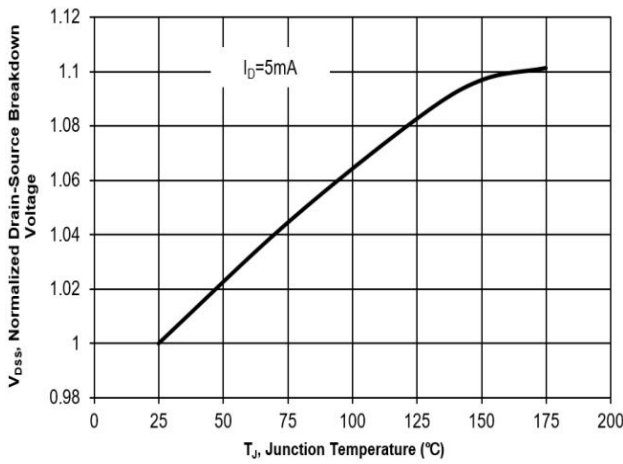

Fig. 10 Gate Threshold Variation vs. T_j

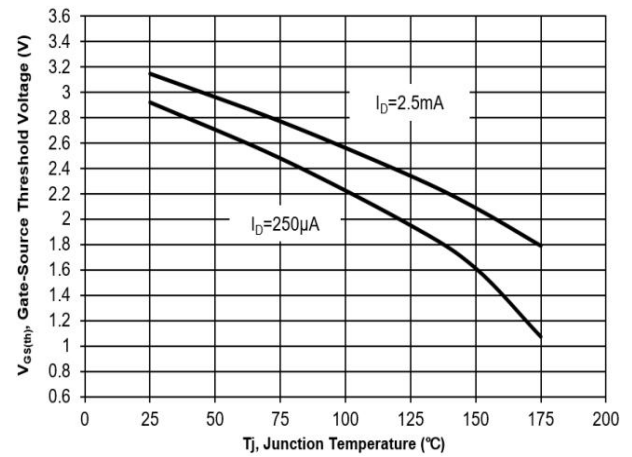

Fig. 11 Gate Charge

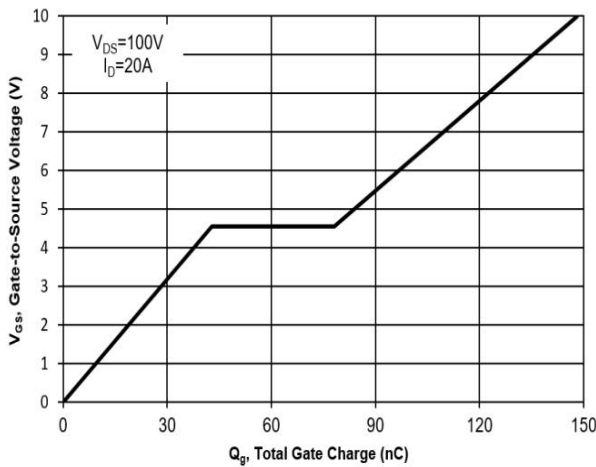
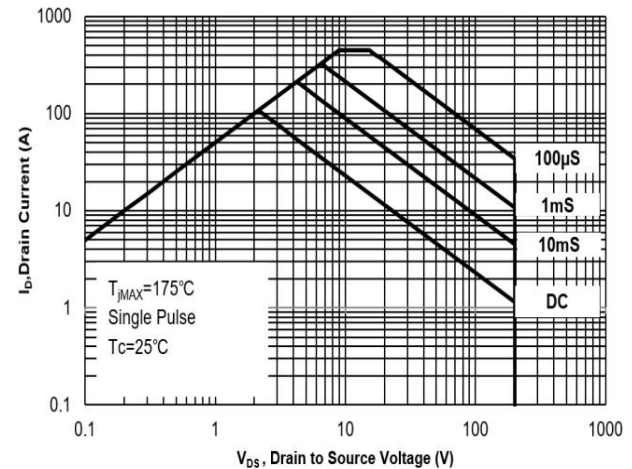

Fig. 12 Safe Operation Area



Typical Characteristics

Fig. 13 Normalized Maximum Transient Thermal Impedance($Z_{\theta JC}$)

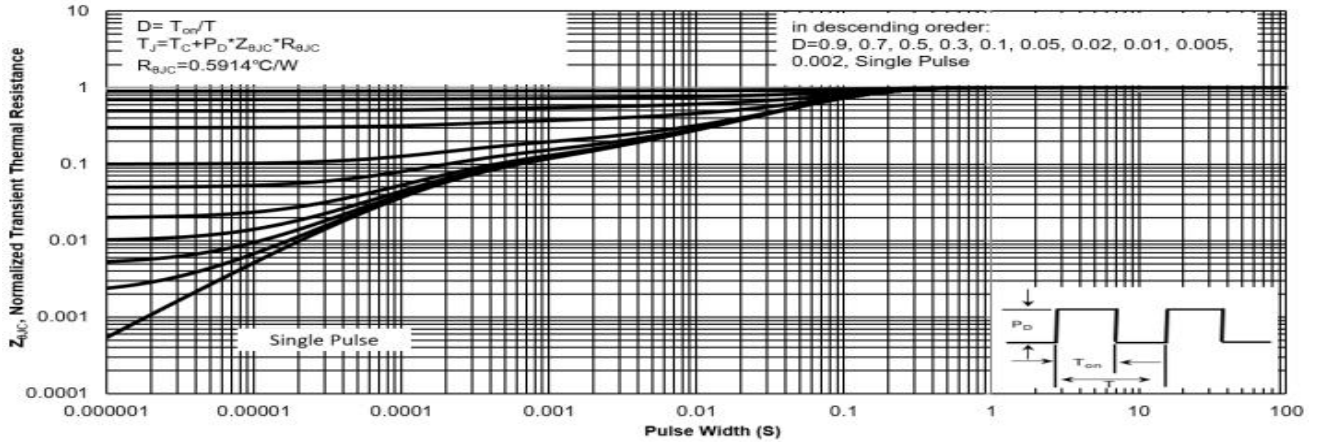
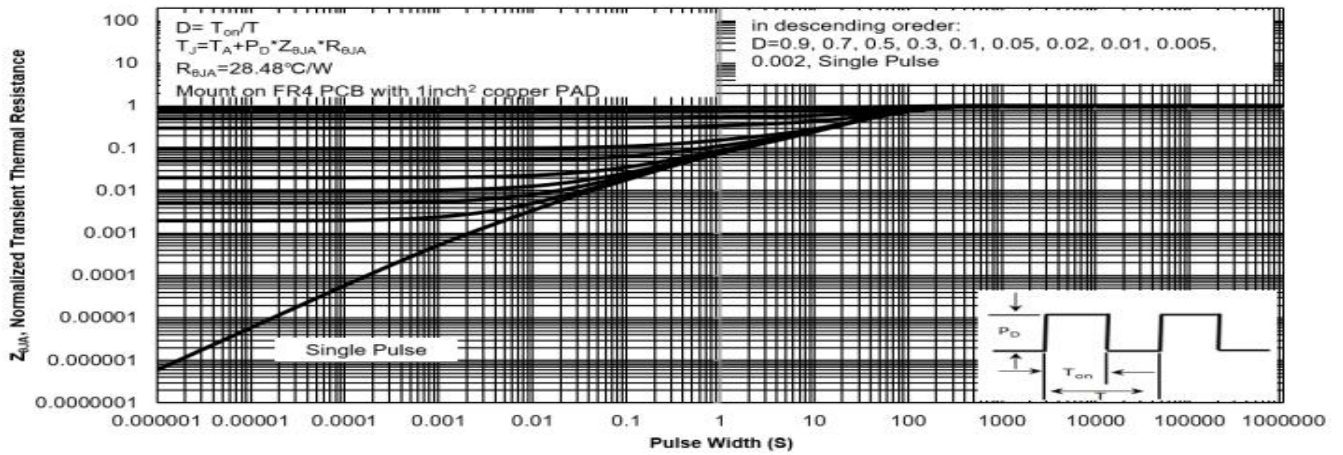
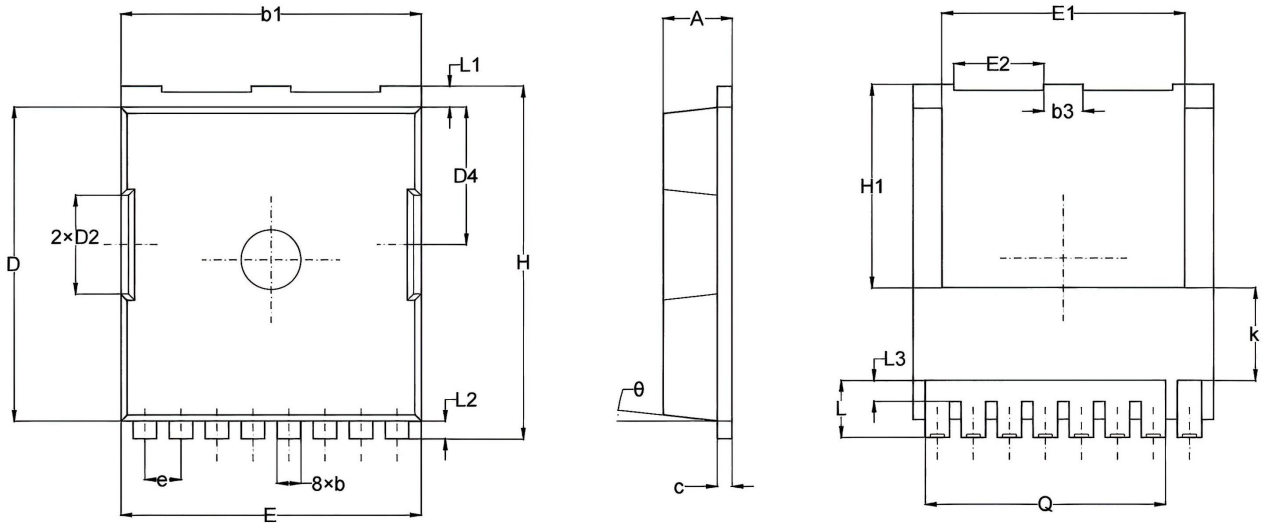

Fig. 14 Normalized Maximum Transient Thermal Impedance($Z_{\theta JA}$)



TOLL Package Information



Symbol	Dimensions In Millimeters		Dimensions In Inches	
	Min.	Max.	Min.	Max.
A	2.200	2.400	0.087	0.094
b	0.650	0.900	0.026	0.035
b1	9.700	9.900	0.382	0.390
b3	1.150	1.350	0.045	0.053
c	0.400	0.600	0.016	0.024
D	10.280	10.480	0.405	0.413
D2	3.200	3.400	0.126	0.134
D4	4.450	4.650	0.175	0.183
E	9.800	10.000	0.386	0.394
E1	7.900	8.300	0.311	0.327
e	1.200 BSC.		0.047 BSC.	
H	11.480	11.880	0.452	0.468
H1	6.950 REF.		0.274 REF.	
k	3.000 REF.		0.118 REF.	
L	1.350	1.750	0.053	0.069
L1	0.500	0.900	0.020	0.035
L2	0.500	0.700	0.020	0.028
L3	0.250	0.650	0.010	0.026
Q	8.000 REF.		0.315 REF.	
E2	2.800	3.200	0.110	0.126
θ	10° REF.		10° REF.	