

Product Summary

$V_{(BR)DSS}$	$R_{DS(on)MAX}$	I_b
60V	6.3mΩ@10V	60A

Feature

- Excellent package for heat dissipation
- High density cell design for low $R_{DS(on)}$
- Suffix "-Q1" for AEC-Q101

Application

- Power switching application
- Uninterruptible power supply
- DC-DC convertor

Package

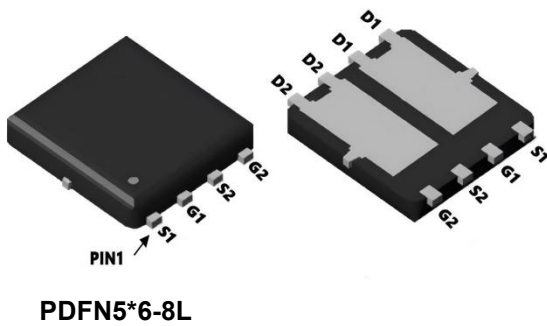

Circuit diagram

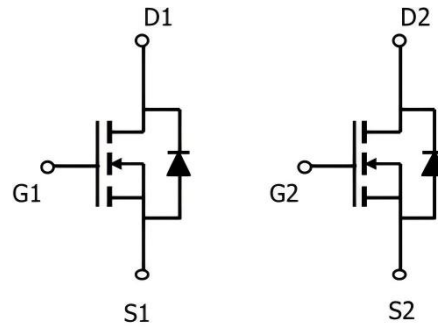

Marking

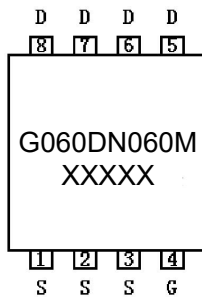

Absolute maximum ratings (T_C=25°C unless otherwise noted)

Parameter	Symbol	Value	Unit
Drain-Source Voltage	V _{DS}	60	V
Gate-Source Voltage	V _{GS}	±20	V
Continuous Drain Current ^{1,3)} (V _{GS} =10V, Chip limitation)	I _D	60	A
Continuous Drain Current ^{1,3)} (V _{GS} =10V, T _C =100°C)	I _D (100°C)	42	A
Pulsed Drain Current (t _p ≤10us)	I _{DM}	240	A
Single Pulse Avalanche Energy ²⁾	E _{AS}	121	mJ
Power Dissipation ^{1,3)}	P _D	93.7	W
Thermal Resistance Junction to Case	R _{θJC}	1.6	°C/W
Operating Junction Temperature	T _J	-55 ~ +175	°C
Storage Temperature Range	T _{STG}	-55 ~ +175	°C

Electrical characteristics (T_J=25 °C, unless otherwise noted)

Parameter	Symbol	Test Condition	Min.	Typ.	Max.	Unit
Static Characteristics						
Drain-source breakdown voltage	V _{(BR)DSS}	V _{GS} =0V, I _D =250μA	60			V
Zero gate voltage drain current	I _{DSS}	V _{DS} =48V, V _{GS} =0V			1	μA
Gate-body leakage current	I _{GSS}	V _{DS} =0V, V _{GS} =±20V			±100	nA
Gate threshold voltage	V _{GS(th)}	V _{DS} =V _{GS} , I _D =250μA	2	3	4	V
Drain-source on-resistance	R _{DS(on)}	V _{GS} =10V, I _D =40A		4.8	6.3	mΩ
Dynamic characteristics⁴⁾						
Input Capacitance	C _{iss}	V _{DS} =30V, V _{GS} =0V, f =1MHz		1529		pF
Output Capacitance	C _{oss}			460		
Reverse Transfer Capacitance	C _{rss}			16		
Total Gate Charge	Q _g	V _{DS} =30V, V _{GS} =10V I _D =37.5A		25.5		nC
Gate-Source Charge	Q _{gs}			6		
Gate-Drain Charge	Q _{gd}			14		
Turn-on delay time	t _{d(on)}	V _{DS} =30V, V _{GS} =10V I _D =37.5A, R _G =2.2Ω		13		nS
Turn-on rise time	t _r			50		
Turn-off delay time	t _{d(off)}			21.8		
Turn-off fall time	t _f			8.6		
Source-Drain Diode characteristics						
Diode Forward Current	I _S	T _C =25°C			60	A
Diode Forward voltage	V _{SD}	V _{GS} =0V, I _S =40A			1.2	V
Reverse Recovery Time	T _{rr}	V _{GS} =0V, V _R =20V, I _F =37.5A		28		nS
Reverse Recovery Charge	Q _{rr}	di/dt =-270A/μs		40		nC

Notes:

- 1) The entire application environment impacts the thermal resistance values shown, they are not constants and are only valid for the particular conditions noted.
- 2) The test condition is T_J =25°C, V_G =10V, L=0.5mH, R_G =25Ω, I_{AS} =22A .
- 3) Thermal resistance from junction to soldering point (on the exposed drain pad).
- 4) Guaranteed by design, not subject to production.

Typical Characteristics

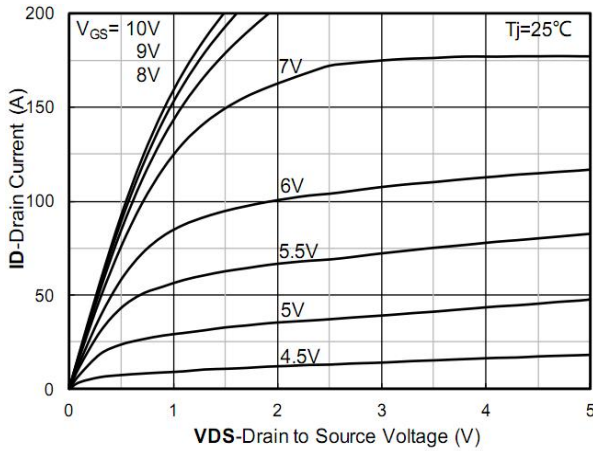

Figure 1. Output Characteristics; typical values

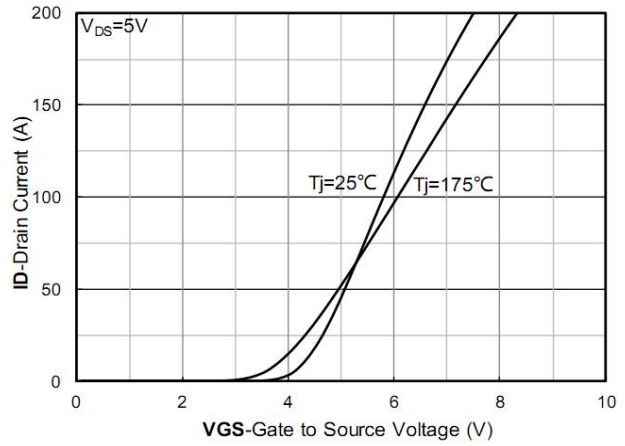

Figure 2. Transfer Characteristics; typical values

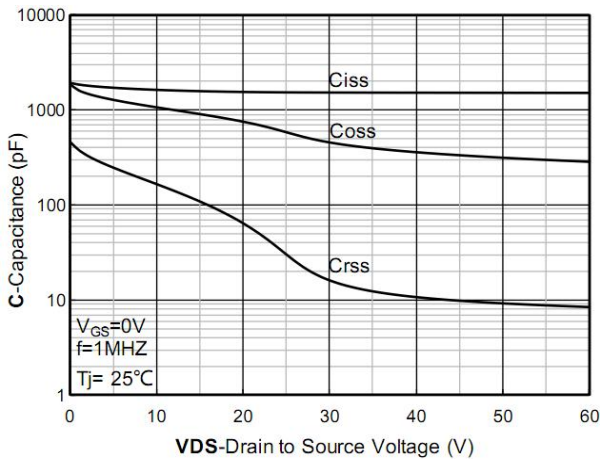

Figure 3. Capacitance Characteristics; typical values

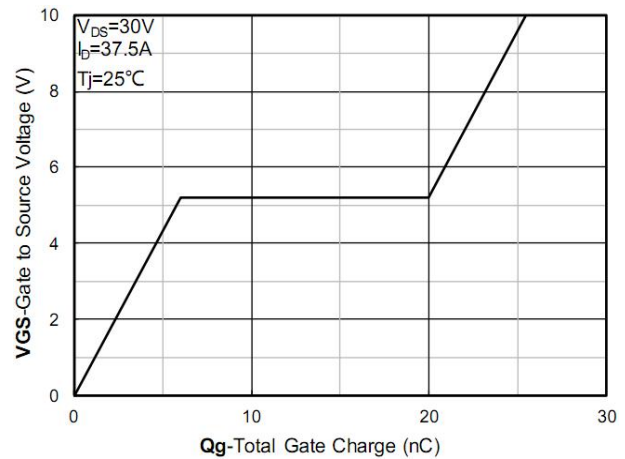

Figure 4. Gate Charge; typical values

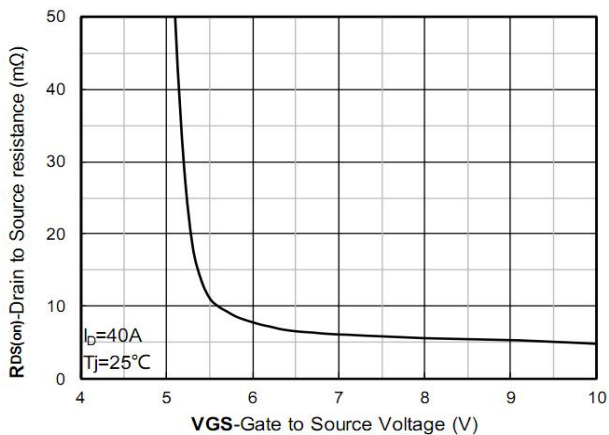

Figure 5. On-Resistance vs. Gate to Source Voltage; typical values

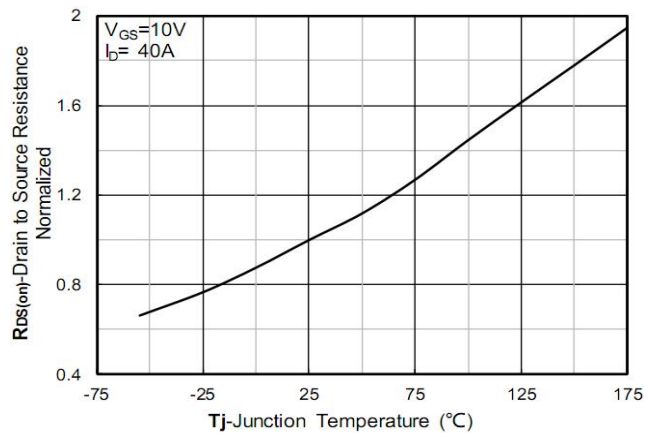

Figure 6. Normalized On-Resistance

Typical Characteristics

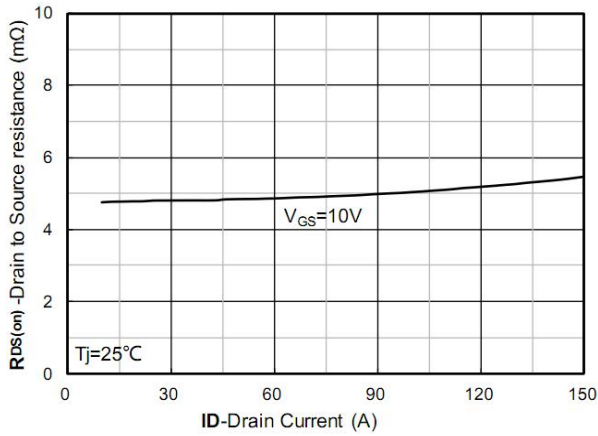

Figure 7. RDS(on) vs. Drain Current; typical values

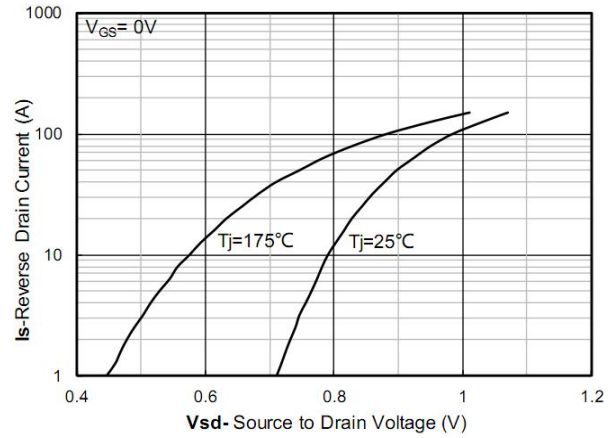

Figure 8. Forward characteristics of reverse diode; typical values

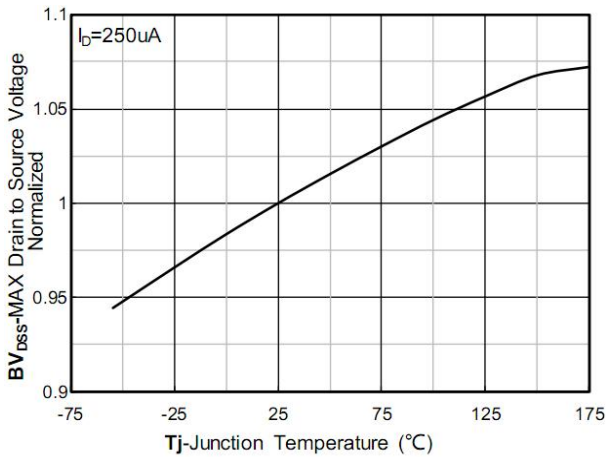

Figure 9. Normalized breakdown voltage

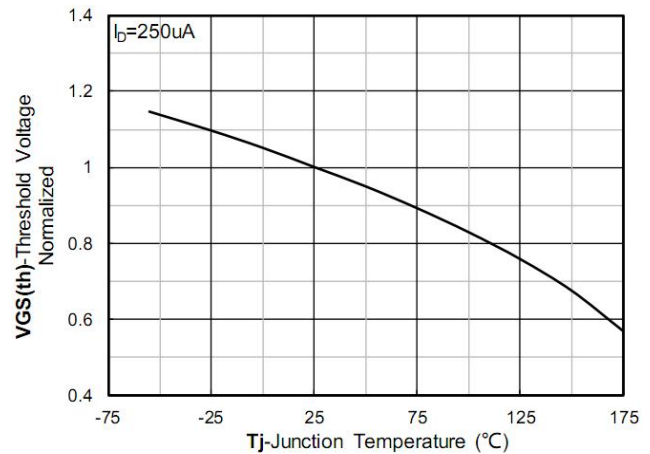

Figure 10. Normalized Threshold voltage

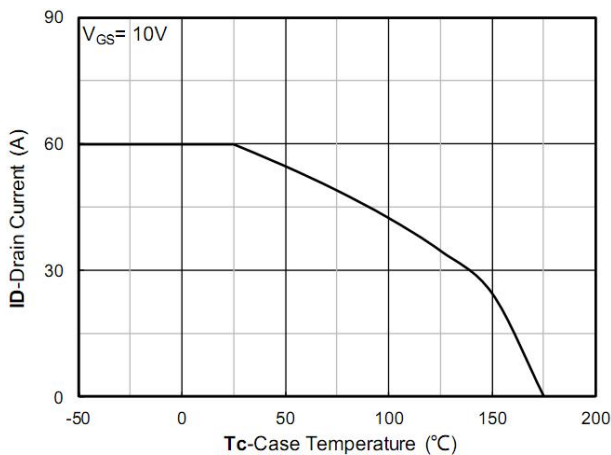

Figure 11. Current dissipation

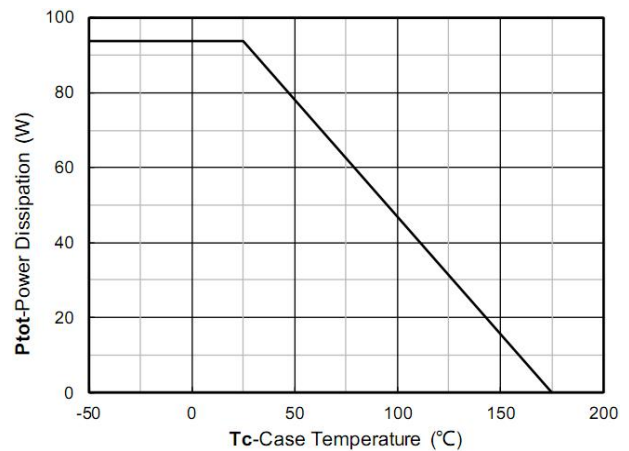

Figure 12. Power dissipation

Typical Characteristics

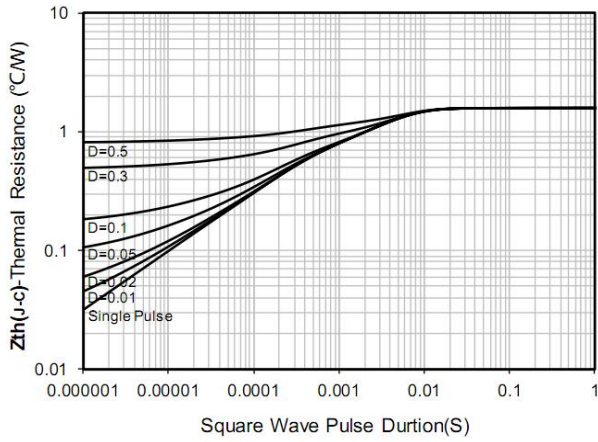

Figure 13. Maximum Transient Thermal Impedance

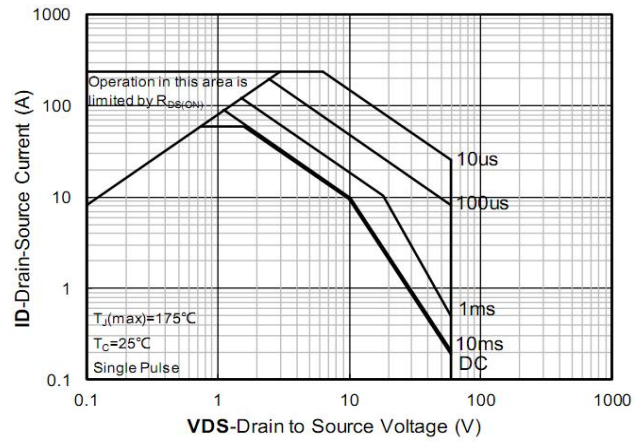
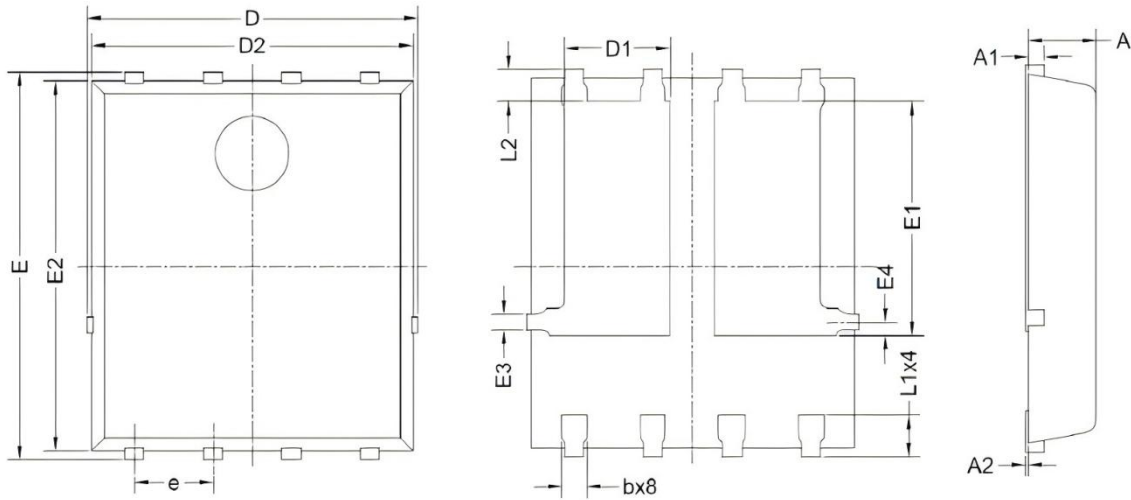

Figure 14. Safe Operation Area

PDFN5*6-8L Package Information



Symbol	Dimensions In Millimeters		Dimensions In Inches	
	Min.	Max.	Min.	Max.
D	5.150	5.550	0.203	0.219
E	5.950	6.350	0.234	0.250
A	1.000	1.200	0.039	0.047
A1	0.254 BSC.		0.010 BSC.	
A2	0.000	0.100	0.000	0.004
D1	1.500	1.900	0.059	0.075
E1	3.520	3.920	0.139	0.154
D2	5.000	5.400	0.197	0.213
E2	5.660	6.060	0.223	0.239
E3	0.254 REF.		0.010 REF.	
E4	0.210 REF.		0.008 REF.	
L1	0.560	0.760	0.022	0.030
L2	0.500 BSC.		0.020 BSC.	
b	0.310	0.510	0.012	0.020
e	1.270 BSC.		0.050 BSC.	