

### Product Summary

$V_{(BR)DSS}$	$R_{DS(on)MAX}$	$I_D$	$V_{(BR)DSS}$	$R_{DS(on)MAX}$	$I_D$
60V	20mΩ@10V	16A	-60V	40mΩ@-10V	-11A
	25mΩ@4.5V			60mΩ@-4.5V	

### Feature

- Extremely low on-resistance
- High current capacity
- Fast switching speed
- Suffix "-Q1" for AEC-Q101

### Application

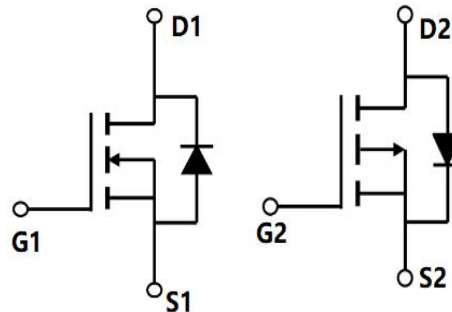
- Synchronous rectification
- Motor control
- Portable equipment application

### Package



SOP-8

### Circuit diagram



### Marking



### Absolute maximum ratings ( $T_A=25^\circ\text{C}$ unless otherwise noted)

Parameter	Symbol	N-Channel	P-Channel	Unit
Drain-Source Voltage	$V_{DS}$	60	-60	V
Gate-Source Voltage	$V_{GS}$	$\pm 20$	$\pm 20$	V
Continuous Drain Current ( $T_C=25^\circ\text{C}$ )	$I_D$	16	-11	A
Continuous Drain Current <sup>1)</sup>	$I_D$	10	-7	A
Continuous Drain Current <sup>1)</sup> ( $T_A=100^\circ\text{C}$ )	$I_{D(100^\circ\text{C})}$	6.3	-4.4	A
Pulsed Drain Current ( $t_p=10\mu\text{s}$ )	$I_{DM}$	60	-50	A
Single Pulse Avalanche Energy <sup>2)</sup>	$E_{AS}$	35	45	mJ
Power Dissipation <sup>1)</sup>	$P_D$	3.1	3.1	W
Thermal Resistance Junction to Ambient <sup>1)</sup>	$R_{\theta JA}$	40	40	$^\circ\text{C}/\text{W}$
Operating Junction Temperature	$T_J$	-55 ~ +150	-55 ~ +150	$^\circ\text{C}$
Storage Temperature	$T_{STG}$	-55 ~ +150	-55 ~ +150	$^\circ\text{C}$

### N-CH Electrical characteristics ( $T_A=25^\circ\text{C}$ , unless otherwise noted)

Parameter	Symbol	Test Condition	Min.	Typ.	Max.	Unit
<b>Static Characteristics</b>						
Drain-source breakdown voltage	$V_{(BR)DSS}$	$V_{GS}=0\text{V}, I_D=250\mu\text{A}$	60			V
Zero gate voltage drain current	$I_{DSS}$	$V_{DS}=60\text{V}, V_{GS}=0\text{V}$			1	$\mu\text{A}$
Gate-body leakage current	$I_{GSS}$	$V_{DS}=0\text{V}, V_{GS}=\pm 20\text{V}$			$\pm 100$	nA
Gate threshold voltage	$V_{GS(th)}$	$V_{DS}=V_{GS}, I_D=250\mu\text{A}$	1	1.8	2.5	V
Drain-source on-resistance <sup>3)</sup>	$R_{DS(on)}$	$V_{GS}=10\text{V}, I_D=10\text{A}$		15	20	m $\Omega$
		$V_{GS}=4.5\text{V}, I_D=10\text{A}$		20	25	
<b>Dynamic characteristics<sup>4)</sup></b>						
Input Capacitance	$C_{iss}$	$V_{DS}=30\text{V}, V_{GS}=0\text{V}, f=1\text{MHz}$		677		pF
Output Capacitance	$C_{oss}$			160		
Reverse Transfer Capacitance	$C_{rss}$			7		
Total Gate Charge	$Q_g$	$V_{DS}=30\text{V}, V_{GS}=10\text{V}, I_D=10\text{A}$		12.7		nC
Gate-Source Charge	$Q_{gs}$			1.8		
Gate-Drain Charge	$Q_{gd}$			3.2		
Turn-on delay time	$t_{d(on)}$	$V_{DS}=30\text{V}, V_{GS}=15\text{V}, I_D=10\text{A}$ $R_G=3.3\Omega$		7		nS
Turn-on rise time	$t_r$			35		
Turn-off delay time	$t_{d(off)}$			22		
Turn-off fall time	$t_f$			24		
<b>Source-Drain Diode characteristics</b>						
Diode Forward Current	$I_S$				16	A
Diode Forward voltage <sup>3)</sup>	$V_{SD}$	$V_{GS}=0\text{V}, I_S=10\text{A}$			1.2	V
Reverse recover time	$T_{rr}$	$V_{GS}=0\text{V}, I_F=10\text{A}$		26		nS
Reverse recovery charge	$Q_{rr}$	$di/dt=-100\text{A}/\mu\text{s}$		15		nC

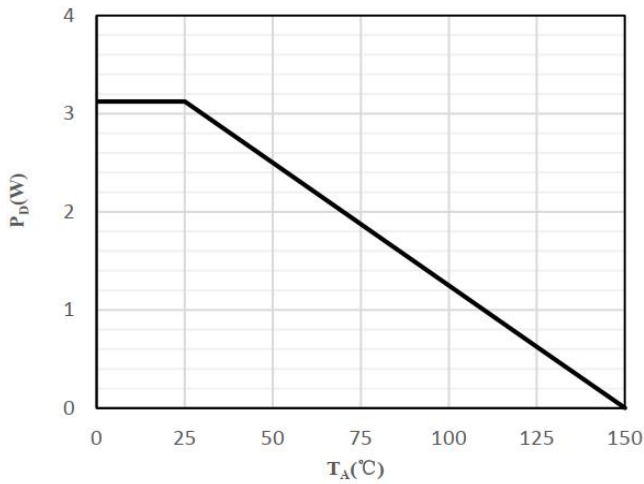
### P-CH Electrical characteristics (T<sub>A</sub>=25 °C, unless otherwise noted)

Parameter	Symbol	Test Condition	Min.	Typ.	Max.	Unit
<b>Static Characteristics</b>						
Drain-source breakdown voltage	V <sub>(BR)DSS</sub>	V <sub>GS</sub> = 0V, I <sub>D</sub> = -250μA	-60			V
Zero gate voltage drain current	I <sub>DSS</sub>	V <sub>DS</sub> = -60V, V <sub>GS</sub> = 0V			-1	μA
Gate-body leakage current	I <sub>GSS</sub>	V <sub>DS</sub> = 0V, V <sub>GS</sub> = ±20V			±100	nA
Gate threshold voltage	V <sub>GS(th)</sub>	V <sub>DS</sub> = V <sub>GS</sub> , I <sub>D</sub> = -250μA	-1	-1.5	-2.5	V
Drain-source on-resistance <sup>3)</sup>	R <sub>DS(on)</sub>	V <sub>GS</sub> = -10V, I <sub>D</sub> = -5A		32	40	mΩ
		V <sub>GS</sub> = -4.5V, I <sub>D</sub> = -4A		40	60	
<b>Dynamic characteristics<sup>4)</sup></b>						
Input Capacitance	C <sub>iss</sub>	V <sub>DS</sub> = -30V, V <sub>GS</sub> = 0V, f = 1MHz		1902		pF
Output Capacitance	C <sub>oss</sub>			104		
Reverse Transfer Capacitance	C <sub>rss</sub>			83		
Total Gate Charge	Q <sub>g</sub>	V <sub>DS</sub> = -30V, V <sub>GS</sub> = -10V I <sub>D</sub> = -5A		37		nC
Gate-Source Charge	Q <sub>gs</sub>			5.5		
Gate-Drain Charge	Q <sub>gd</sub>			6		
Turn-on delay time	t <sub>d(on)</sub>	V <sub>DS</sub> = -30V, V <sub>GS</sub> = -10V I <sub>D</sub> = -5A, R <sub>G</sub> = 3Ω		4.3		nS
Turn-on rise time	t <sub>r</sub>			6.3		
Turn-off delay time	t <sub>d(off)</sub>			46.7		
Turn-off fall time	t <sub>f</sub>			25.3		
<b>Source-Drain Diode characteristics</b>						
Diode Forward Current	I <sub>S</sub>				-11	A
Diode Forward voltage <sup>3)</sup>	V <sub>SD</sub>	V <sub>GS</sub> = 0V, I <sub>S</sub> = -5A			-1.2	V
Reverse recover time	T <sub>rr</sub>	V <sub>GS</sub> = 0V, I <sub>F</sub> = -5A di/dt = -100A/us		28		nS
Reverse recovery charge	Q <sub>rr</sub>			17		nC

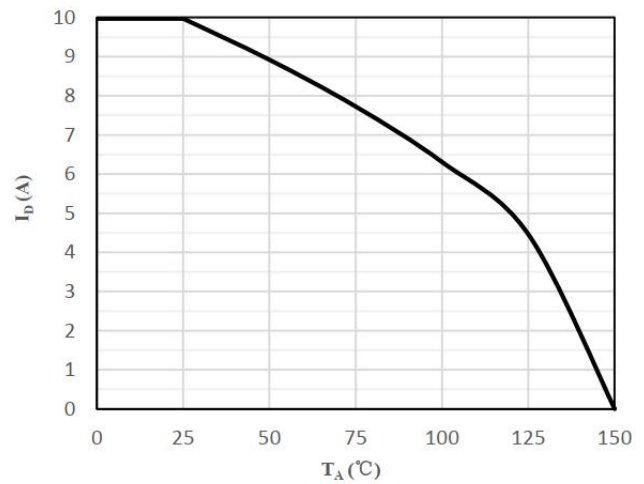
Notes:

- 1) The data tested by surface mounted on a 1 inch2 FR-4 board with 2OZ copper.
- 2) The EAS data shows Max. rating. The test condition is N-Channel: V<sub>DD</sub> = 30V, V<sub>GS</sub> = 10V, L = 0.5mH; P-Channel: V<sub>DD</sub> = -30V, V<sub>GS</sub> = -10V, L = 0.5mH.
- 3) The data tested by pulsed, pulse width ≤300us, duty cycle ≤2%.
- 4) Guaranteed by design, not subject to production testing.

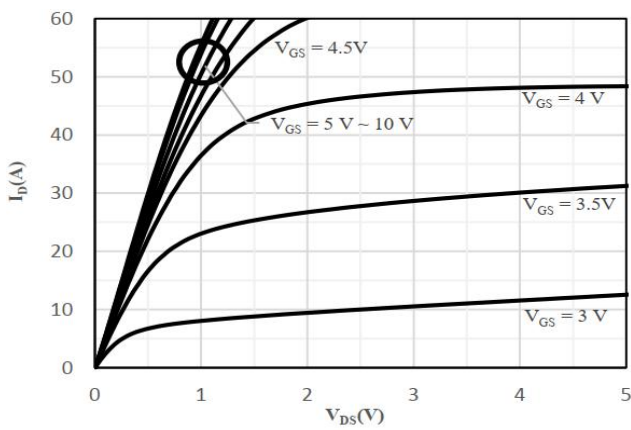
## N-Channel Typical Characteristics



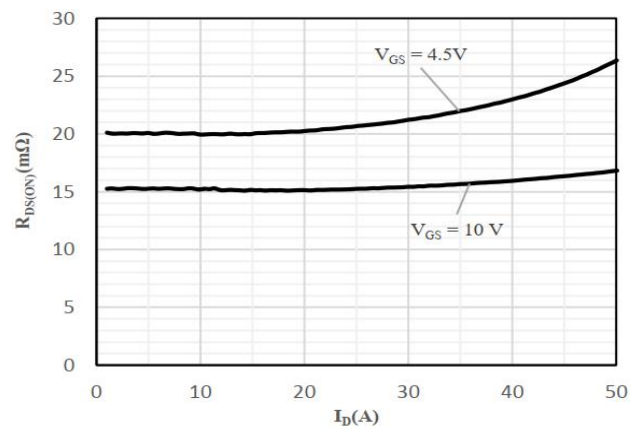
**Fig 1 Power Dissipation**



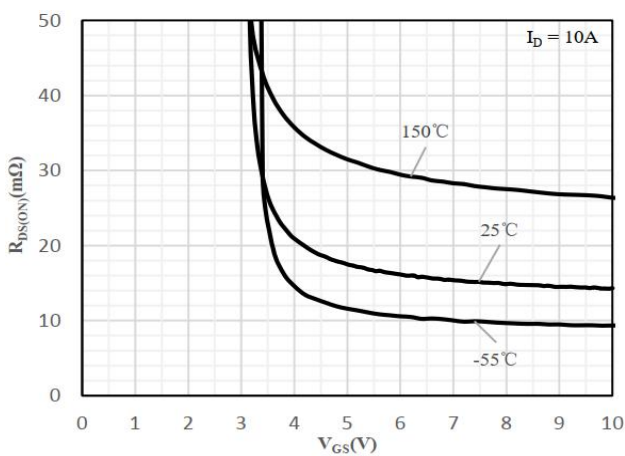
**Fig 2 Drain Current**



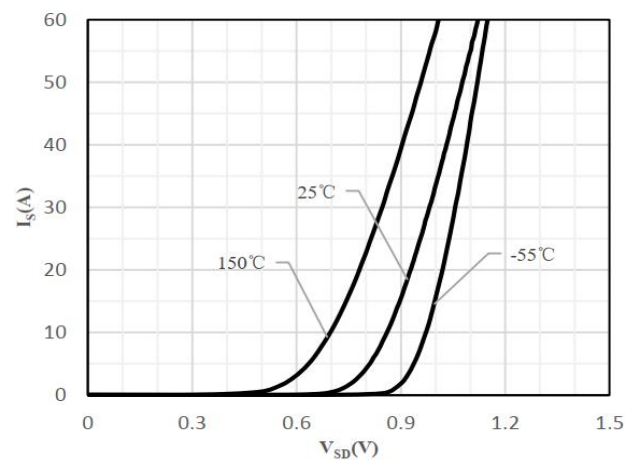
**Fig 3 Typical Output Characteristics**



**Fig 4 On-Resistance vs. Drain Current and Gate Voltage**

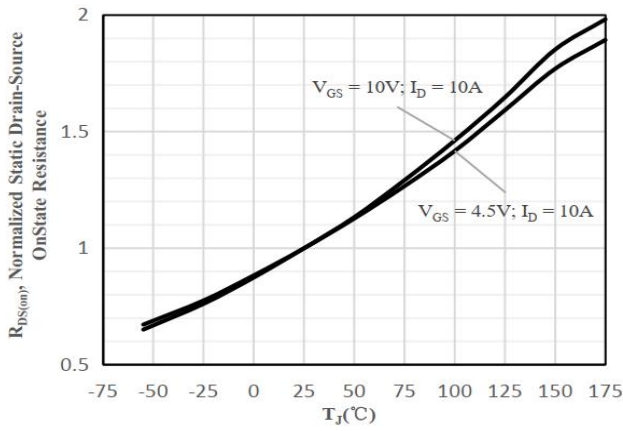


**Fig 5 On-Resistance vs. Gate-Source Voltage**

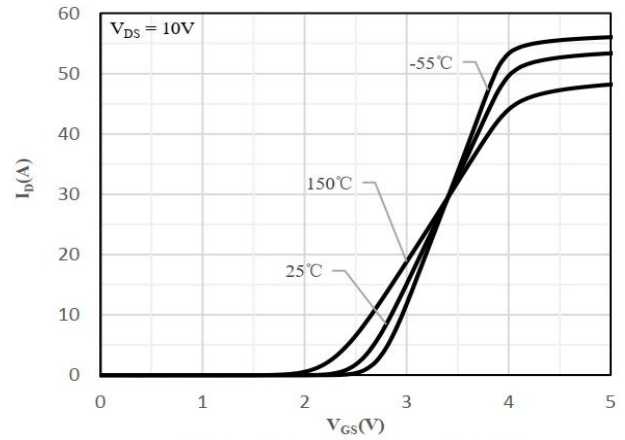


**Fig 6 Body-Diode Characteristics**

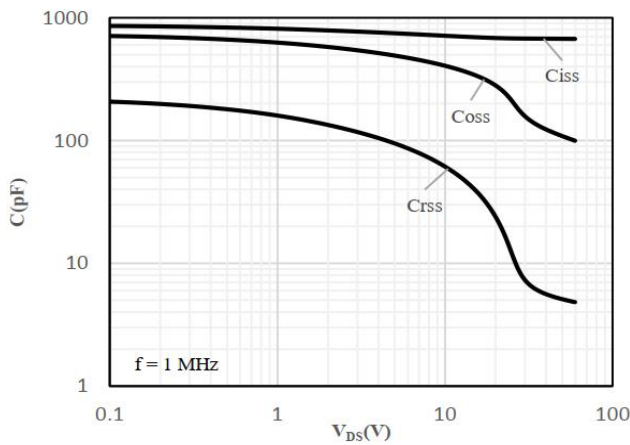
## N-Channel Typical Characteristics



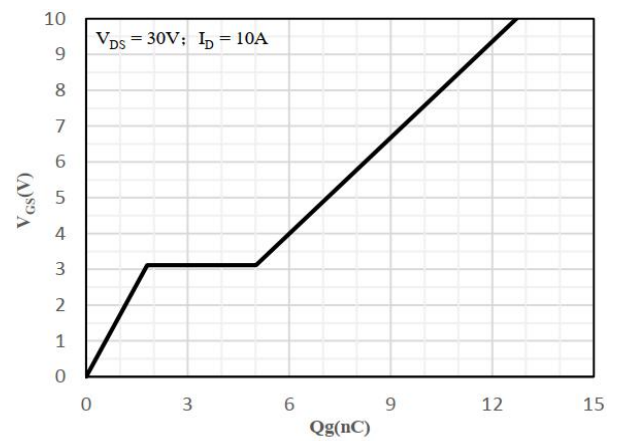
**Fig 7 Normalized On-Resistance vs. Junction Temperature**



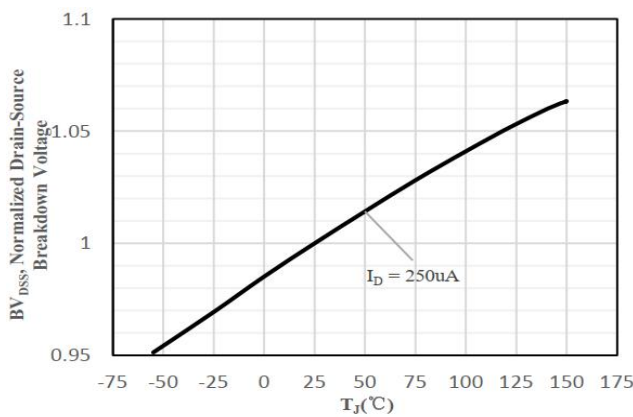
**Fig 8 Transfer Characteristics**



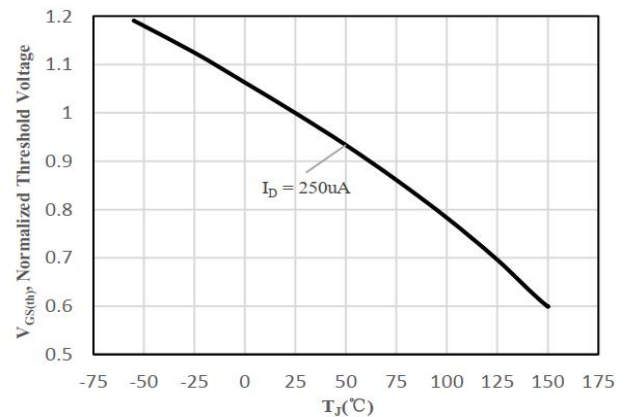
**Fig 9 Capacitance Characteristics**



**Fig 10 Gate-Charge Characteristics**

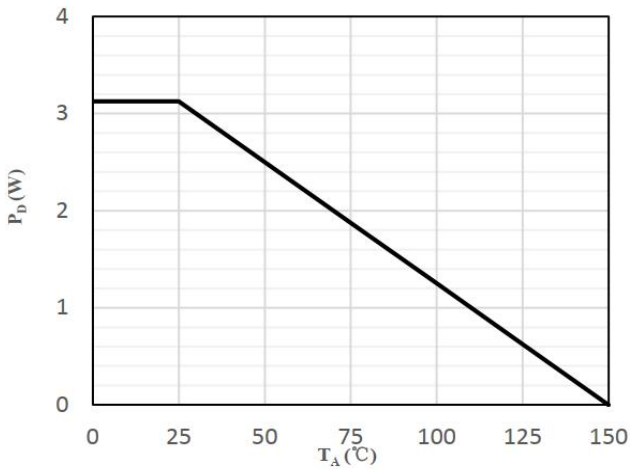


**Fig 11 Normalized Breakdown Voltage vs. Junction Temperature**

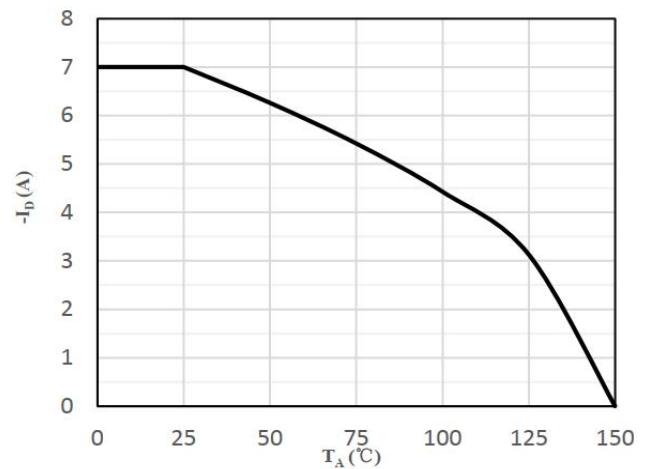


**Fig 12 Normalized  $V_{GS(th)}$  vs. Junction Temperature**

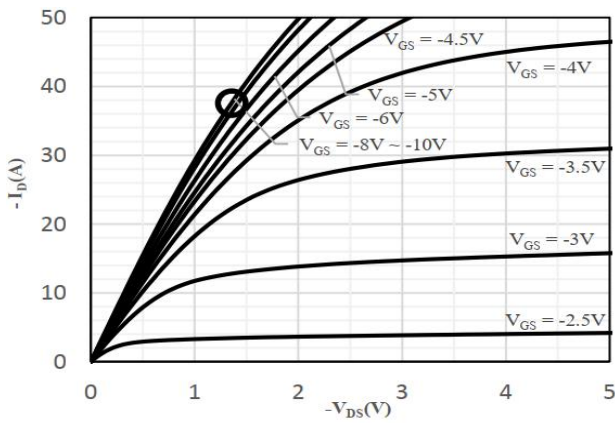
## P-Channel Typical Characteristics



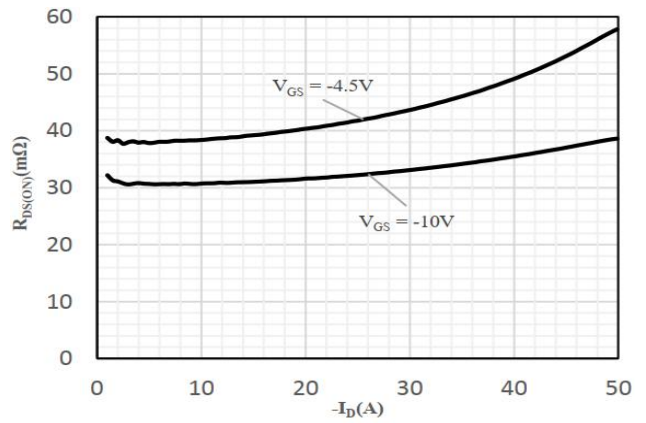
**Fig 1 Power Dissipation**



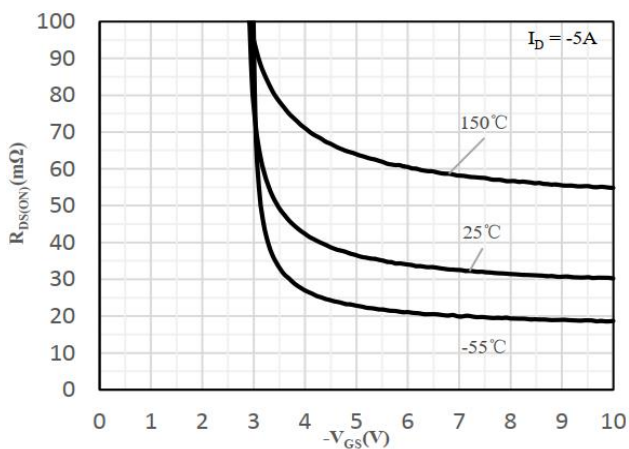
**Fig 2 Drain Current**



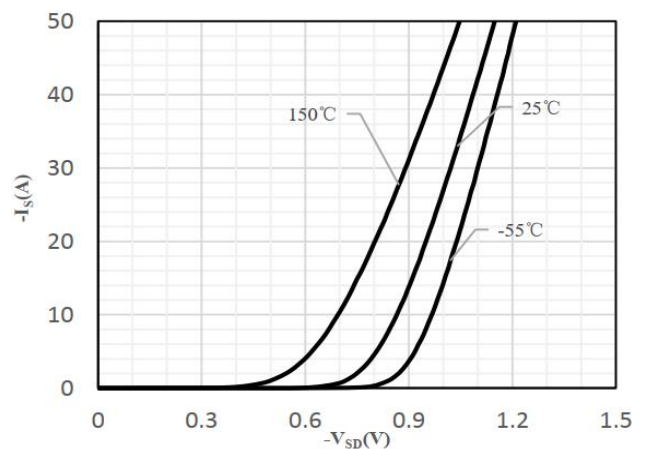
**Fig 3 Typical Output Characteristics**



**Fig 4 On-Resistance vs. Drain Current and Gate Voltage**

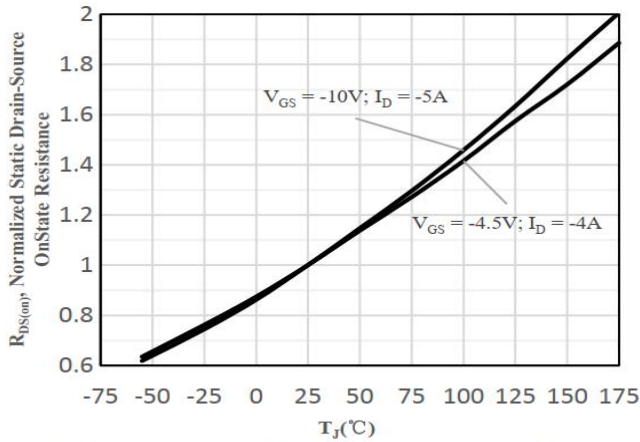


**Fig 5 On-Resistance vs. Gate-Source Voltage**

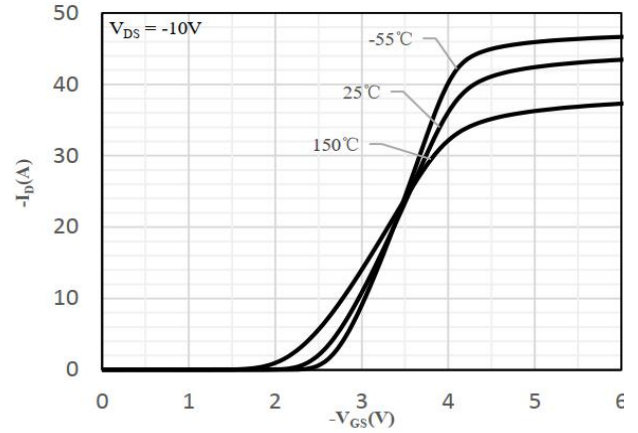


**Fig 6 Body-Diode Characteristics**

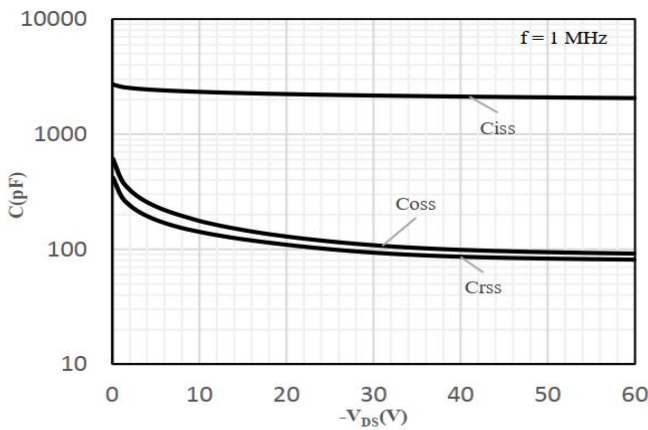
## P-Channel Typical Characteristics



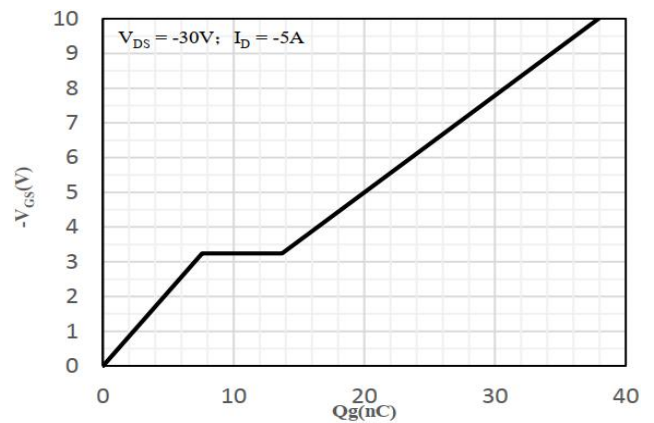
**Fig 7 Normalized On-Resistance vs. Junction Temperature**



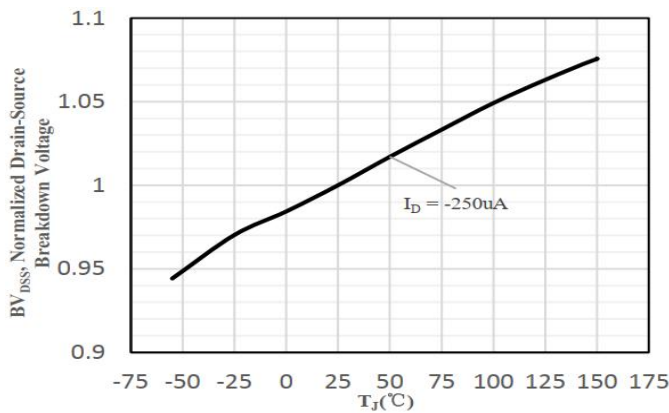
**Fig 8 Transfer Characteristics**



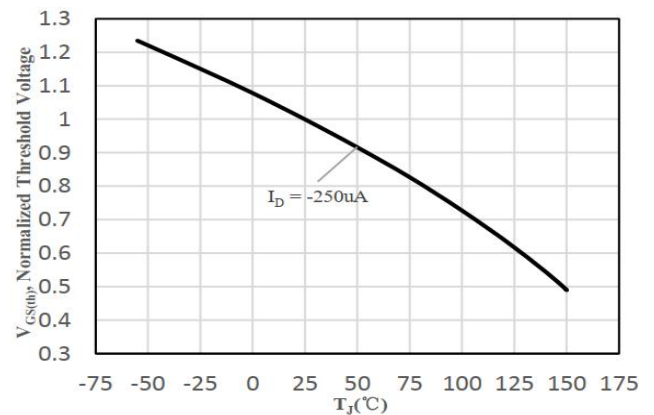
**Fig 9 Capacitance Characteristics**



**Fig 10 Gate-Charge Characteristics**

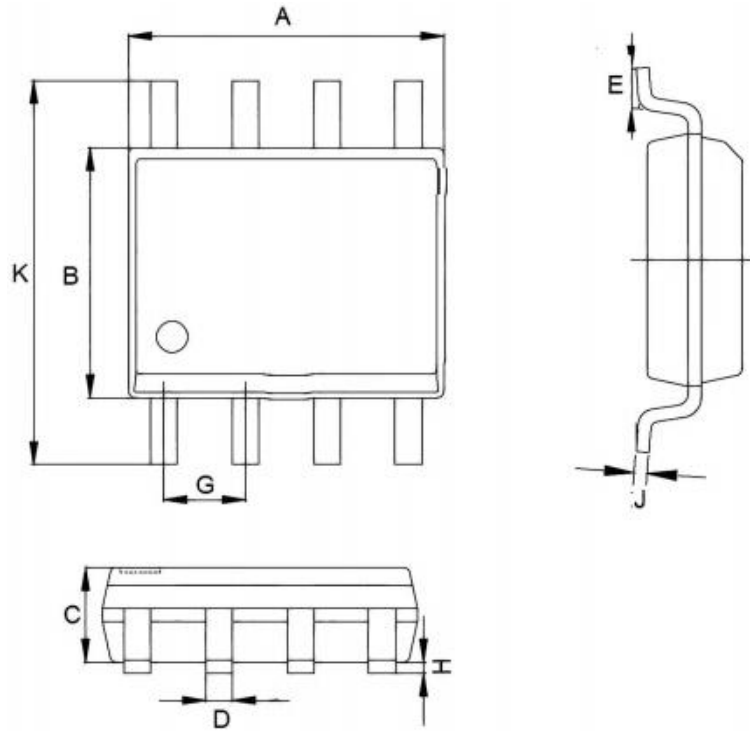


**Fig 11 Normalized Breakdown Voltage vs. Junction Temperature**



**Fig 12 Normalized  $V_{GS(th)}$  vs. Junction Temperature**

## SOP-8 Package Information



Symbol	Dimensions In Millimeters		Dimensions In Inches	
	Min.	Max.	Min.	Max.
A	4.800	5.200	0.189	0.205
B	3.800	4.200	0.150	0.165
C	1.300	1.500	0.051	0.059
D	0.300	0.500	0.012	0.020
E	0.400	1.000	0.016	0.039
G	1.170	1.370	0.046	0.054
H	0.100	0.300	0.004	0.012
J	0.100	0.300	0.004	0.012
K	5.800	6.200	0.228	0.244