

Product Summary

$V_{(BR)DSS}$	$R_{DS(on)MAX}$	I_D
60V	11mΩ@10V	10A
	15mΩ@4.5V	

Feature

- Split gate trench MOSFET technology
- Low $R_{DS(on)}$ & FOM
- Extremely low switching loss
- Excellent stability and uniformity

Application

- Uninterruptible power supply
- DC-DC convertor
- Power switching application

Package



Circuit diagram

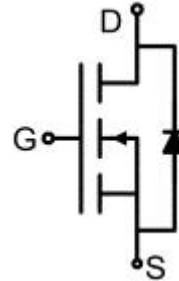

Marking

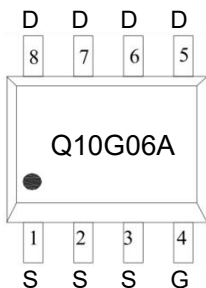

Absolute maximum ratings ($T_A=25^\circ\text{C}$ unless otherwise noted)

Parameter	Symbol	Value	Unit
Drain-Source Voltage	V_{DS}	60	V
Gate-Source Voltage	V_{GS}	± 20	V
Continuous Drain Current	I_D	10	A
Continuous Drain Current ($T_A=100^\circ\text{C}$)	$I_{D(100^\circ\text{C})}$	6	A
Pulsed Drain Current ¹⁾	I_{DM}	100	A
Single Pulse Avalanche Energy ²⁾	E_{AS}	84	mJ
Power Dissipation ³⁾	P_D	2.5	W
Thermal Resistance Junction to Ambient ⁴⁾	$R_{\theta JA}$	50	$^\circ\text{C}/\text{W}$
Operating Junction Temperature	T_J	-55 ~ +150	$^\circ\text{C}$
Storage Temperature	T_{STG}	-55 ~ +150	$^\circ\text{C}$

Electrical characteristics ($T_J=25^\circ\text{C}$, unless otherwise noted)

Parameter	Symbol	Test Condition	Min.	Typ.	Max.	Unit
Static Characteristics						
Drain-source breakdown voltage	$V_{(BR)DSS}$	$V_{GS} = 0\text{V}, I_D = 250\mu\text{A}$	60			V
Zero gate voltage drain current	I_{DSS}	$V_{DS} = 60\text{V}, V_{GS} = 0\text{V}$			1	μA
Gate-body leakage current	I_{GSS}	$V_{DS} = 0\text{V}, V_{GS} = \pm 20\text{V}$			± 100	nA
Gate threshold voltage	$V_{GS(th)}$	$V_{DS} = V_{GS}, I_D = 250\mu\text{A}$	1	1.85	3	V
Drain-source on-resistance	$R_{DS(on)}$	$V_{GS} = 10\text{V}, I_D = 10\text{A}$		8.5	11	m Ω
		$V_{GS} = 4.5\text{V}, I_D = 8\text{A}$		11	15	
Dynamic characteristics⁵⁾						
Input Capacitance	C_{iss}	$V_{DS} = 30\text{V}, V_{GS} = 0\text{V}, f = 1\text{MHz}$		1390		pF
Output Capacitance	C_{oss}			315		
Reverse Transfer Capacitance	C_{rss}			25		
Total Gate Charge	Q_g	$V_{DS} = 30\text{V}, V_{GS} = 10\text{V}, I_D = 5\text{A}$		26		nC
Gate-Source Charge	Q_{gs}			6		
Gate-Drain Charge	Q_{gd}			5		
Turn-on delay time	$t_{d(on)}$	$V_{DS} = 30\text{V}, V_{GS} = 10\text{V}, I_D = 5\text{A}$ $R_G = 3\Omega$		11		nS
Turn-on rise time	t_r			24		
Turn-off delay time	$t_{d(off)}$			28		
Turn-off fall time	t_f			25		
Source-Drain Diode characteristics						
Diode Forward Current	I_S				10	A
Diode Forward voltage	V_{SD}	$V_{GS} = 0\text{V}, I_S = 10\text{A}$			1.2	V
Reverse recover time	T_{rr}	$I_F = 5\text{A}, di/dt = -100\text{A}/\mu\text{s}$		30		nS
Reverse recovery charge	Q_{rr}			22		nC

Notes:

- 1) Repetitive rating; pulse width limited by max. junction temperature.
- 2) $T_J=25^\circ\text{C}$, $V_{DD}=50\text{V}$, $V_G=10\text{V}$, $R_G=25\Omega$, $L=1\text{mH}$, $I_{AS}=13\text{A}$.
- 3) P_D is based on max. junction temperature, using junction-case thermal resistance.
- 4) The value of $R_{\theta JA}$ is measured with the device mounted on 1 in² FR-4 board with 2oz. Copper, in the still air environment with $T_A = 25^\circ\text{C}$. The maximum allowed junction temperature of 150°C . The value in any given application depends on the user's specific board design.
- 5) Guaranteed by design, not subject to production testing.

Typical Characteristics

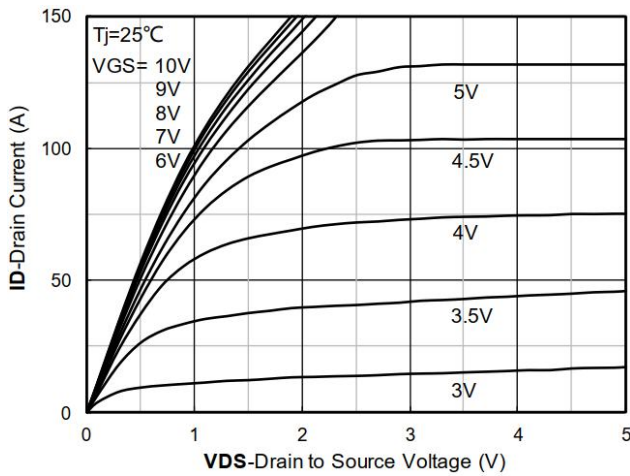

Figure 1. Output Characteristics

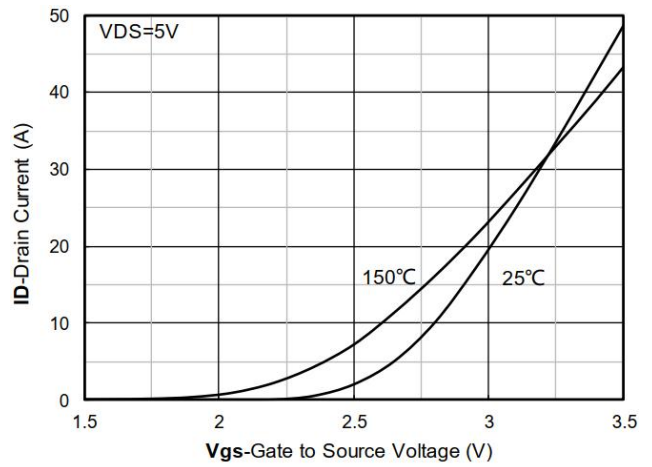

Figure 2. Transfer Characteristics

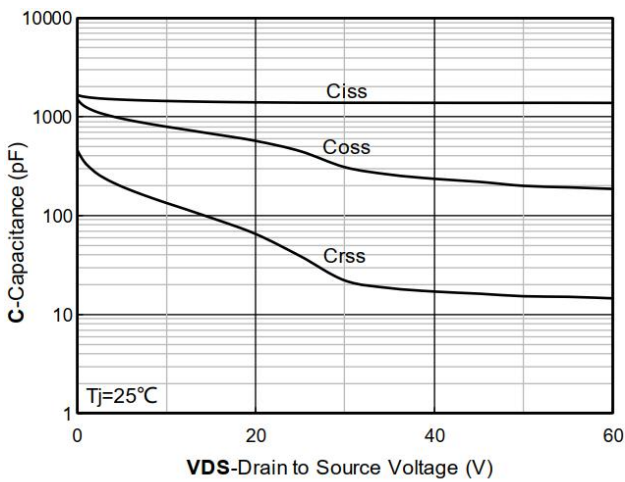

Figure 3. Capacitance Characteristics

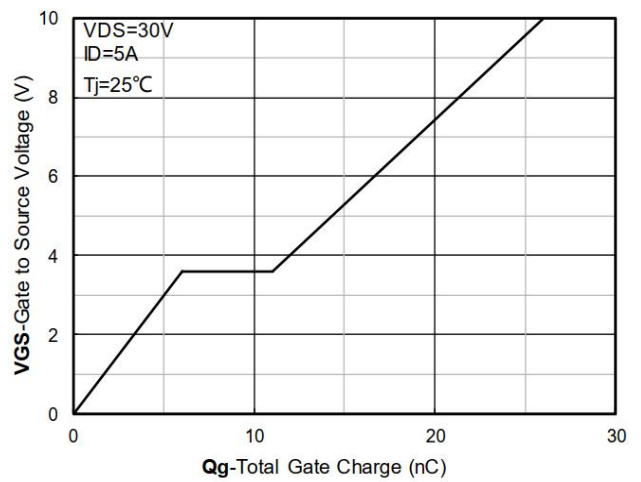

Figure 4. Gate Charge

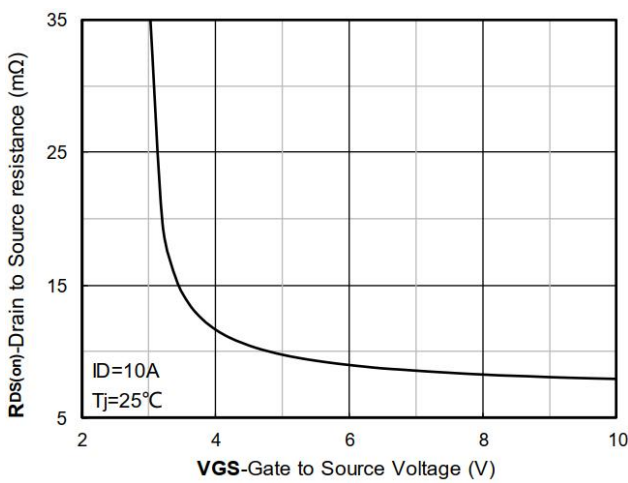

Figure 5. On-Resistance vs Gate to Source Voltage

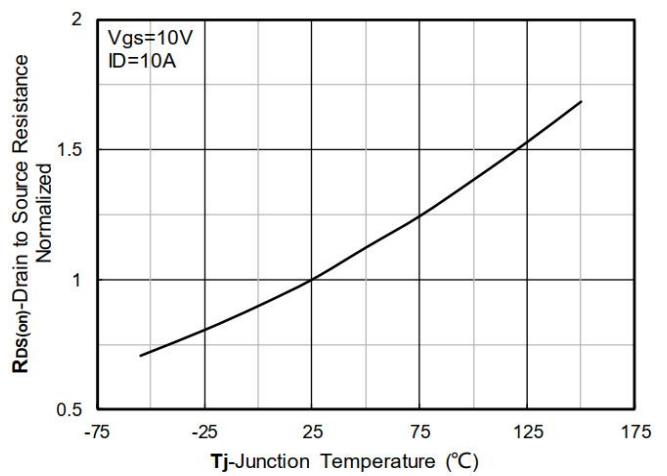

Figure 6. Normalized On-Resistance

Typical Characteristics

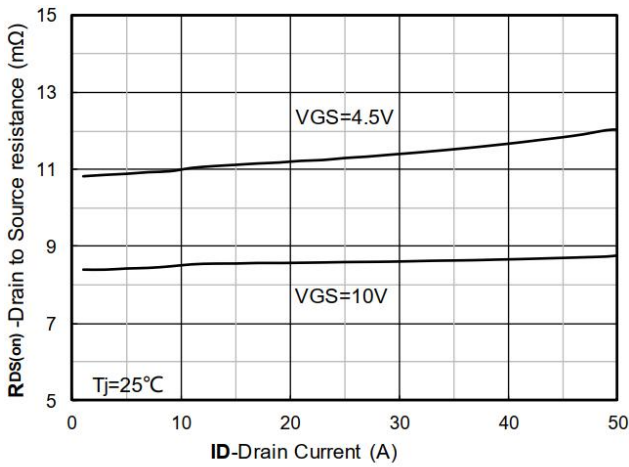

Figure 7. $R_{DS(on)}$ VS Drain Current

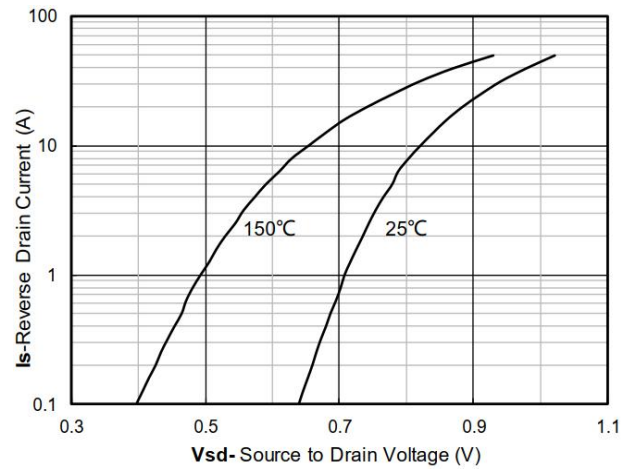

Figure 8. Forward characteristics of reverse diode

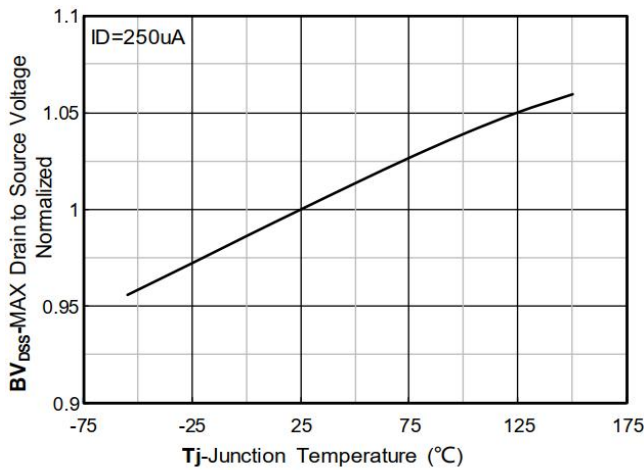

Figure 9. Normalized breakdown voltage

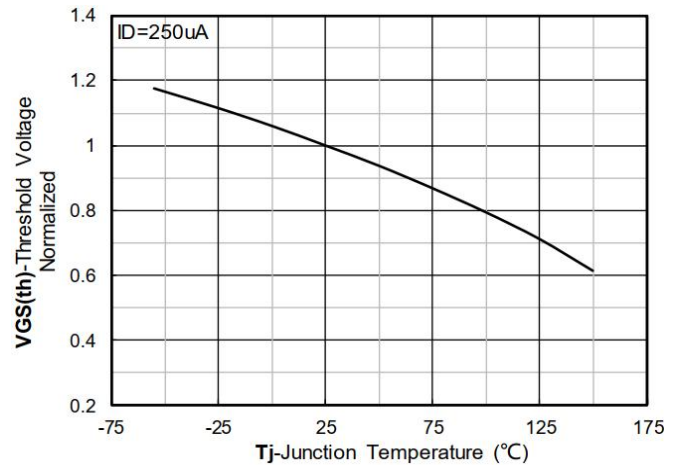

Figure 10. Normalized Threshold voltage

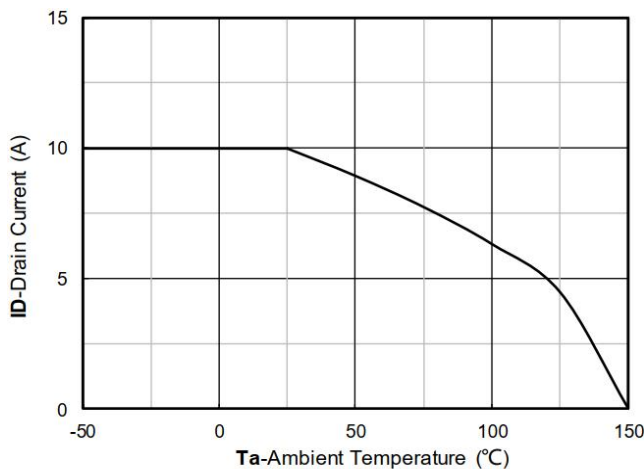

Figure 11. Current dissipation

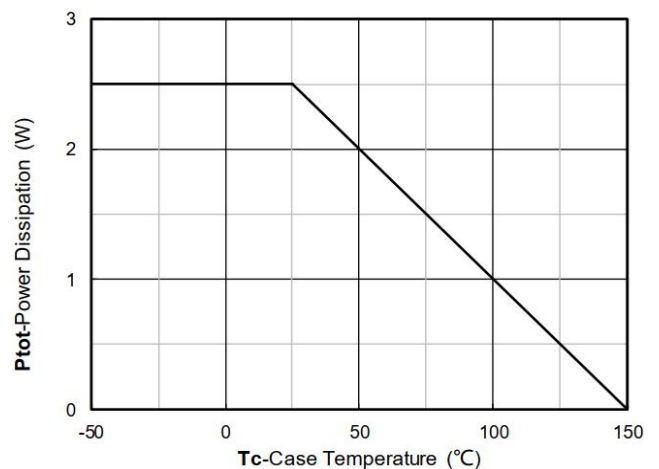

Figure 12. Power dissipation

Typical Characteristics

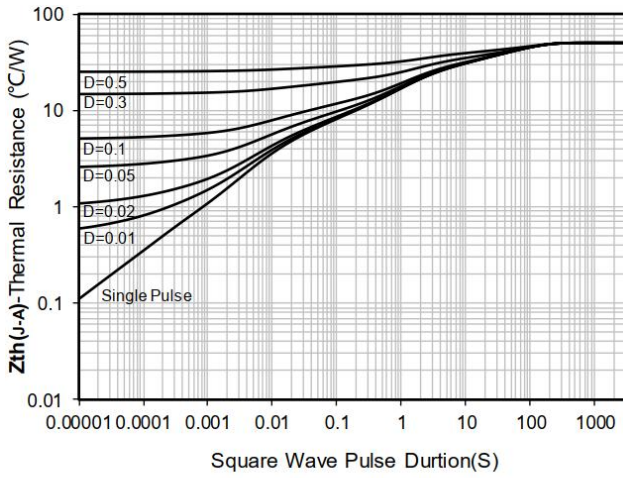

Figure 13. Maximum Transient Thermal Impedance

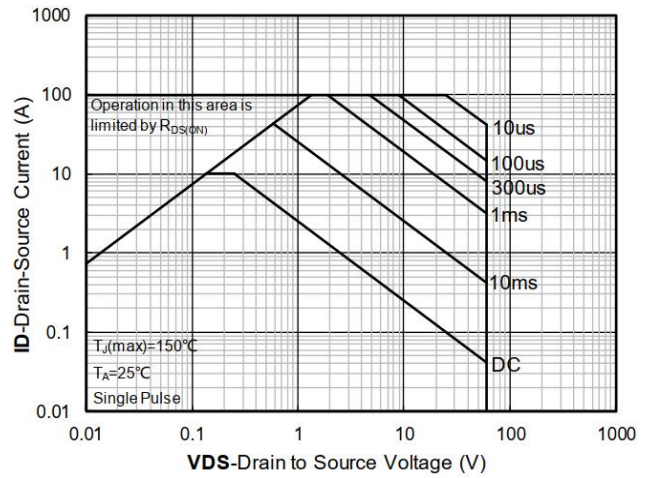
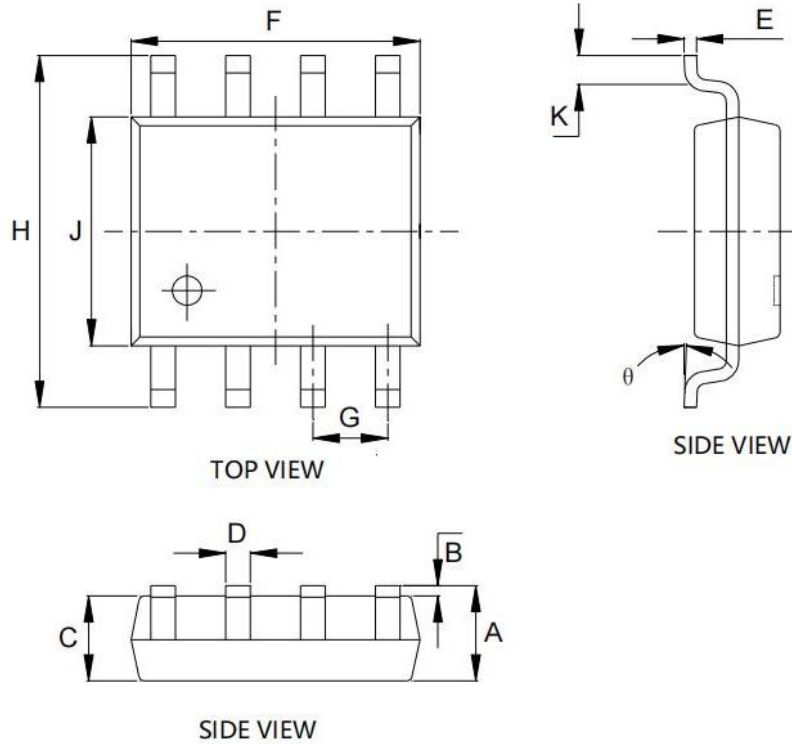

Figure 14. Safe Operation Area

SOP-8 Package Information



Symbol	Dimensions In Millimeters		Dimensions In Inches	
	Min.	Max.	Min.	Max.
A	1.350	1.750	0.053	0.069
B	0.100	0.250	0.004	0.010
C	1.350	1.550	0.053	0.061
D	0.330	0.510	0.013	0.020
E	0.170	0.250	0.007	0.010
F	4.800	5.000	0.189	0.197
G	1.270 BSC.		0.050 BSC.	
H	5.800	6.200	0.228	0.244
J	3.800	4.000	0.150	0.157
K	0.400	1.270	0.016	0.050
θ	0°	8°	0°	8°