

### Product Summary

$V_{(BR)DSS}$	$R_{DS(on)MAX}$	$I_D$
200V	80mΩ@10V	24A

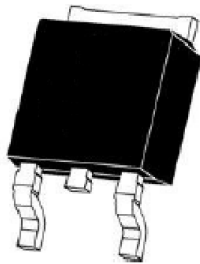
### Feature

- High density cell design for ultra low Rdson
- Fully characterized avalanche voltage and current
- Good stability and uniformity with high  $E_{AS}$
- Excellent package for good heat dissipation

### Application

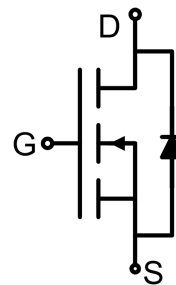
- Power switching application
- Hard switched and high frequency circuits
- Uninterruptible power supply

### Package



TO-252AB

### Circuit diagram



### Marking



### Absolute maximum ratings (Ta=25°C unless otherwise noted)

Parameter	Symbol	Value	Unit
Drain-Source Voltage	$V_{DS}$	200	V
Gate-Source Voltage	$V_{GS}$	±20	V
Continuous Drain Current	$I_D$	24	A
Pulsed Drain Current	$I_{DM}$	100	A
Power Dissipation	$P_D$	150	W
Thermal Resistance, Junction-to-Case	$R_{\theta JC}$	1	°C/W
Single pulse avalanche energy	$E_{AS}$	250	mJ
Junction Temperature	$T_J$	150	°C
Storage Temperature	$T_{STG}$	-55 ~ +150	°C

### Electrical characteristics (T<sub>A</sub>=25 °C, unless otherwise noted)

Parameter	Symbol	Test Condition	Min.	Typ.	Max.	Unit
<b>Static Characteristics</b>						
Drain-source breakdown voltage	$V_{(BR)DSS}$	$V_{GS} = 0V, I_D = 250\mu A$	200			V
Zero gate voltage drain current	$I_{DSS}$	$V_{DS} = 200V, V_{GS} = 0V$			1	μA
Gate-body leakage current	$I_{GSS}$	$V_{GS} = \pm 20V, V_{DS} = 0V$			±100	nA
Gate threshold voltage	$V_{GS(th)}$	$V_{DS} = V_{GS}, I_D = 250\mu A$	2.5		4.0	V
Drain-source on-resistance <sup>1)</sup>	$R_{DS(on)}$	$V_{GS} = 10V, I_D = 15A$			80	mΩ
Forward transconductance <sup>1)</sup>	$g_{FS}$	$V_{DS} = 50V, I_D = 15A$	30			S
<b>Dynamic characteristics<sup>2)</sup></b>						
Input Capacitance	$C_{iss}$	$V_{DS} = 25V, V_{GS} = 0V, f = 1MHz$		4200		pF
Output Capacitance	$C_{oss}$			163		
Reverse Transfer Capacitance	$C_{rss}$			75		
Total Gate Charge	$Q_g$	$V_{DS} = 100V, V_{GS} = 10V, I_D = 15A$		60		nC
Gate-Source Charge	$Q_{gs}$			19		
Gate-Drain Charge	$Q_{gd}$			17		
Turn-on delay time	$t_{d(on)}$	$V_{DD} = 100V, V_{GS} = 10V, I_D = 15A, R_{GEN} = 2.5\Omega$		10		nS
Turn-on rise time	$t_r$			18		
Turn-off delay time	$t_{d(off)}$			22		
Turn-off fall time	$t_f$			5		
<b>Source-Drain Diode characteristics</b>						
Diode Forward Current <sup>1)</sup>	$I_S$				24	A
Diode Forward voltage	$V_{DS}$	$V_{GS} = 0V, I_S = 11A$			1.2	V
Reverse Recovery Time	$t_{rr}$	$T_J = 25^\circ C, I_F = 15A, di/dt = 100A/\mu s$ <sup>1)</sup>		90		nS
Reverse Recovery Charge	$Q_{rr}$			300		nC

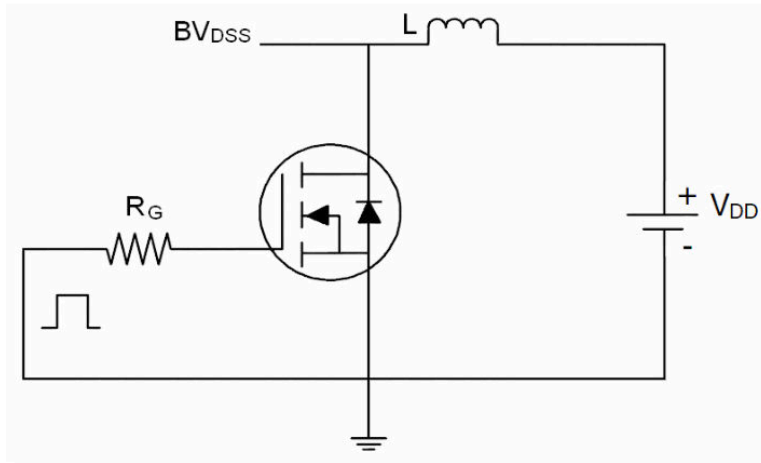
Notes:

1) Pulse Test: Pulse Width < 300μs, Duty Cycle ≤2%.

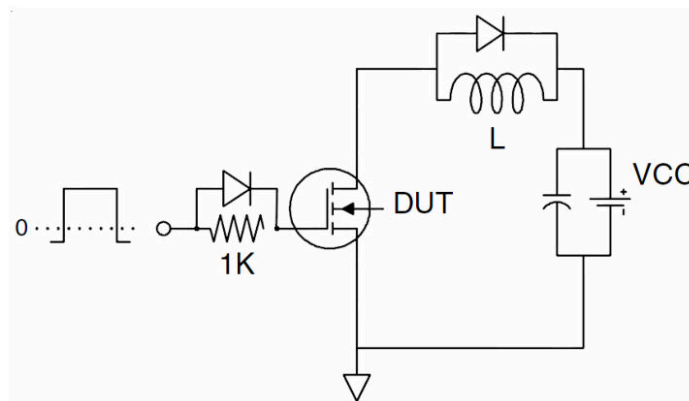
2) Guaranteed by design, not subject to production testing.

## Test Circuit

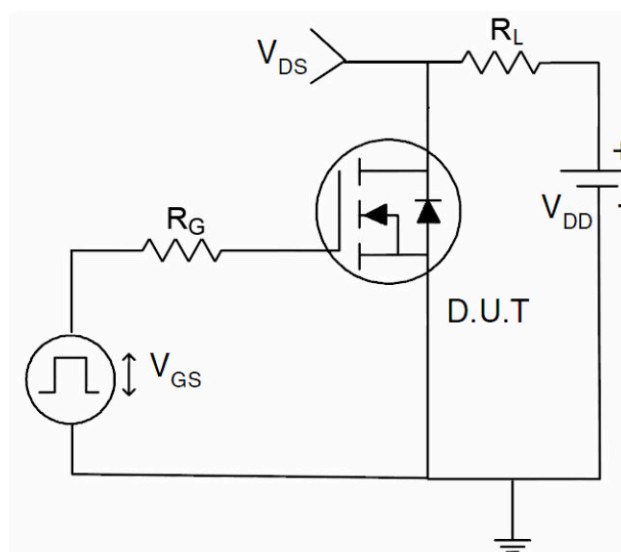
### 1) $E_{AS}$ test Circuit



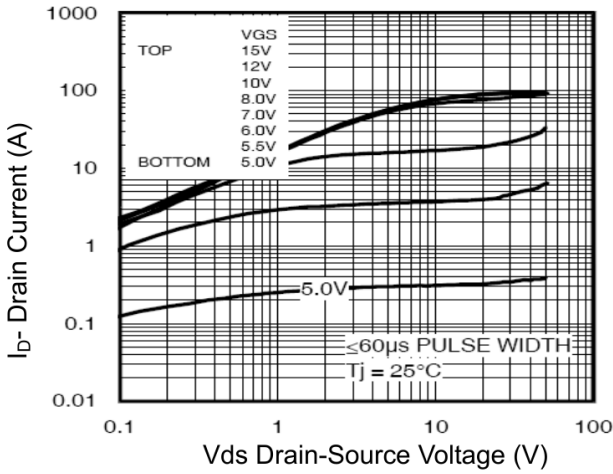
### 2) Gate charge test Circuit



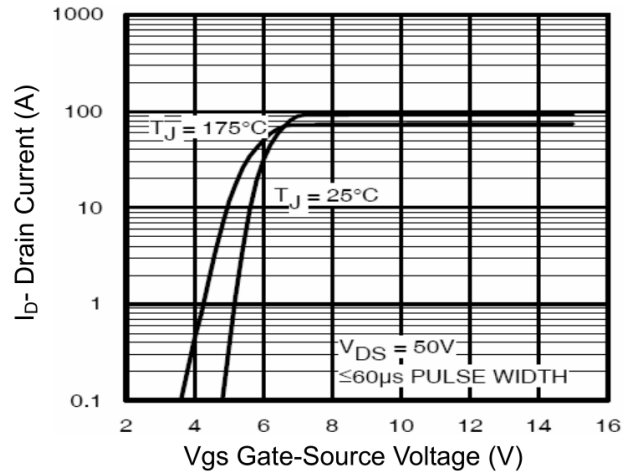
### 3) Switch Time Test Circuit



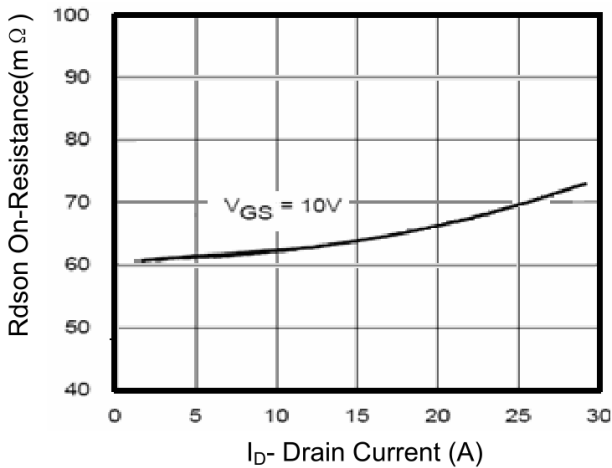
## Typical Characteristics



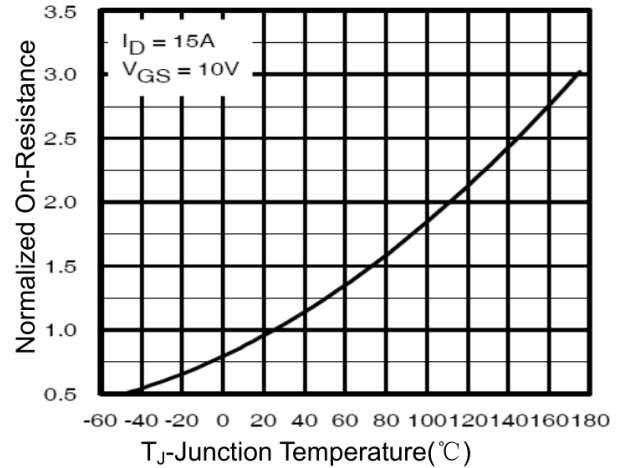
**Figure 1 Output Characteristics**



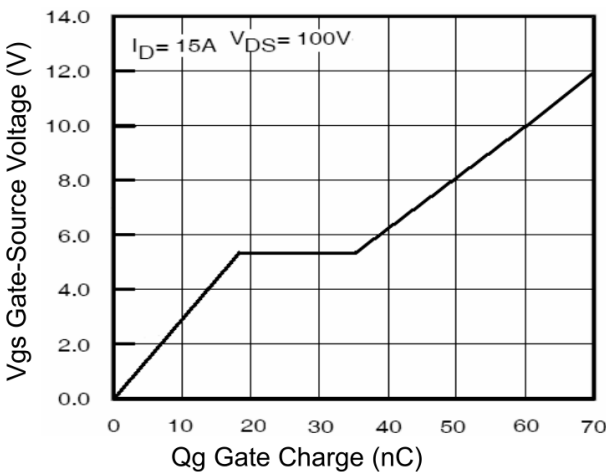
**Figure 2 Transfer Characteristics**



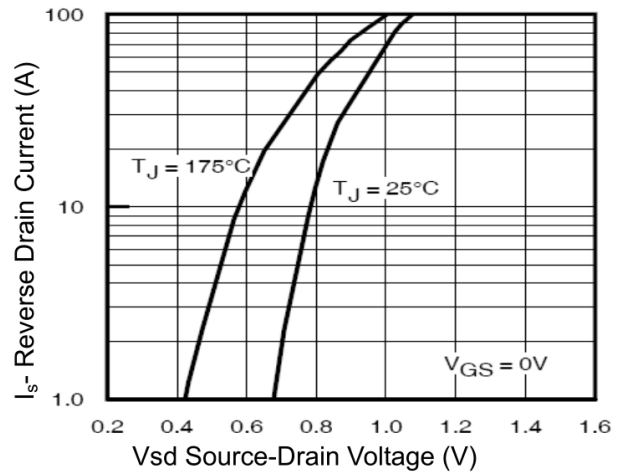
**Figure 3 Rdson- Drain Current**



**Figure 4 Rdson-Junction Temperature**

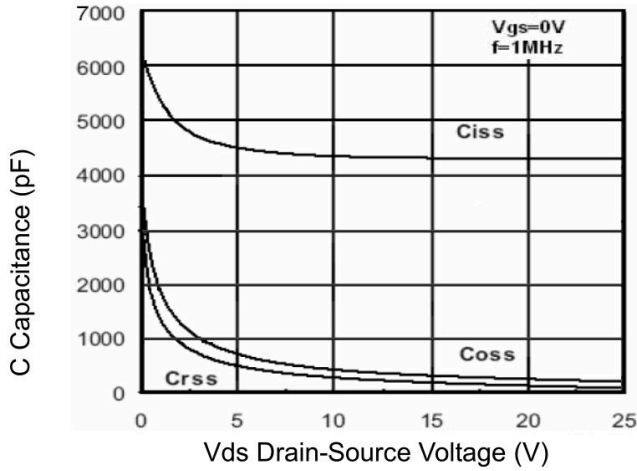


**Figure 5 Gate Charge**

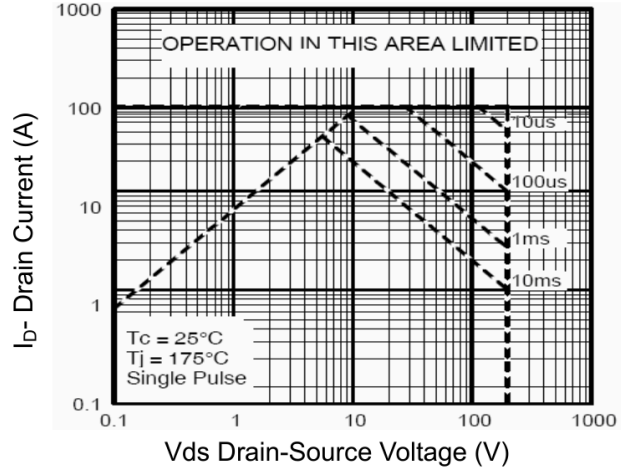


**Figure 6 Source- Drain Diode Forward**

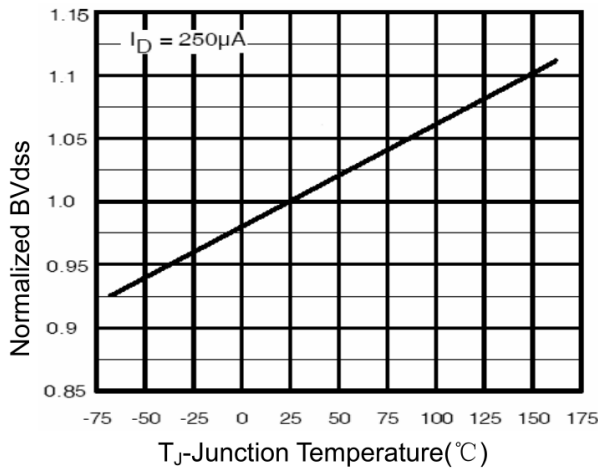
## Typical Characteristics



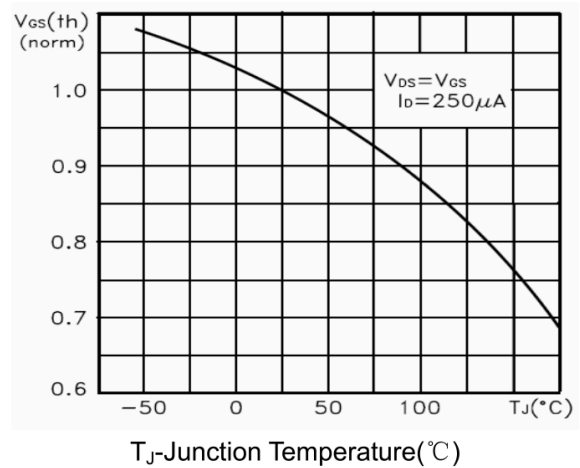
**Figure 7 Capacitance vs Vds**



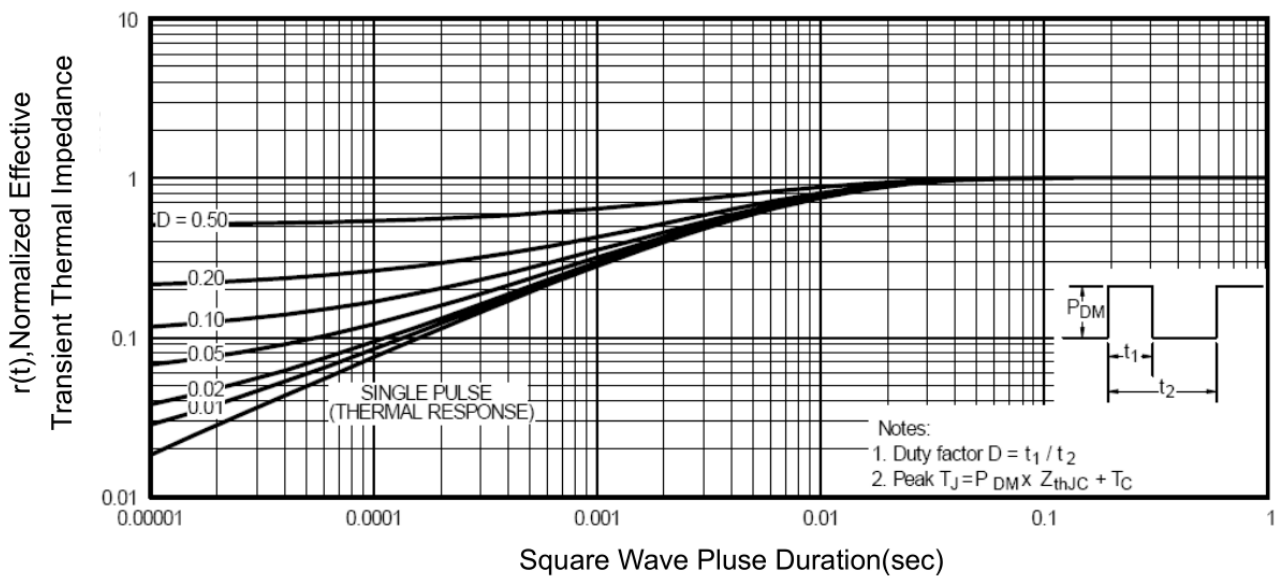
**Figure 8 Safe Operation Area**



**Figure 9 BV<sub>DSS</sub> vs Junction Temperature**

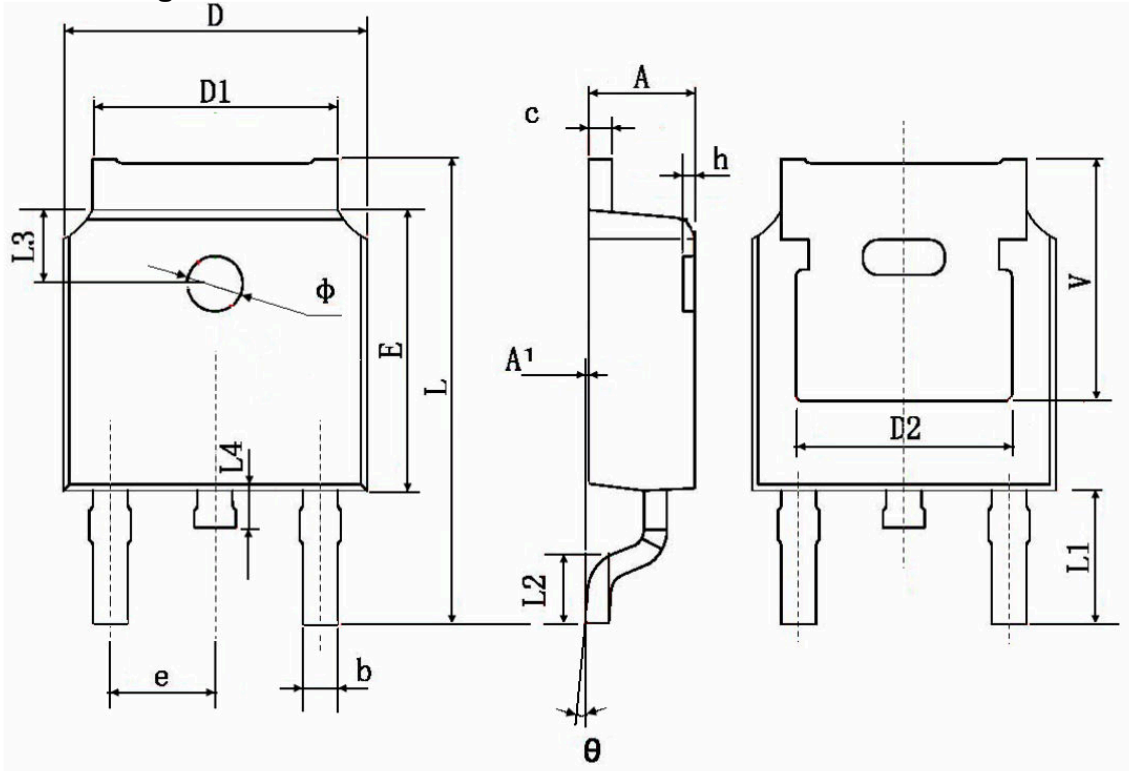


**Figure 10 V<sub>GS(th)</sub> vs Junction Temperature**



**Figure 11 Normalized Maximum Transient Thermal Impedance**

### TO-252AB Package Information



Symbol	Dimensions In Millimeters		Dimensions In Inches	
	Min.	Max.	Min.	Max.
A	2.200	2.400	0.087	0.094
A1	0.000	0.127	0.000	0.005
b	0.660	0.860	0.026	0.034
c	0.460	0.580	0.018	0.023
D	6.500	6.700	0.256	0.264
D1	5.100	5.460	0.201	0.215
D2	4.830 TYP.		0.190 TYP.	
E	6.000	6.200	0.236	0.244
e	2.186	2.386	0.086	0.094
L	9.800	10.400	0.386	0.409
L1	2.900 TYP.		0.114 TYP.	
L2	1.400	1.700	0.055	0.067
L3	1.600 TYP.		0.063 TYP.	
L4	0.600	1.000	0.024	0.039
Φ	1.100	1.300	0.043	0.051
θ	0°	8°	0°	8°
h	0.000	0.300	0.000	0.012
V	5.350 TYP.		0.211 TYP.	