

## Product Summary

$V_{(BR)DSS}$	$R_{DS(on)MAX}$	$I_b$
60V	4mΩ@10V	120A
	5mΩ@4.5V	

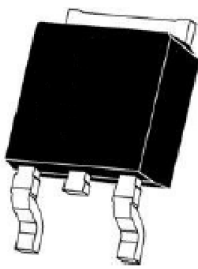
## Feature

- Excellent gate charge x  $R_{DS(on)}$  product
- Very low on-resistance  $R_{DS(on)}$
- Pb-free lead plating
- Suffix "-Q1" for AEC-Q101

## Application

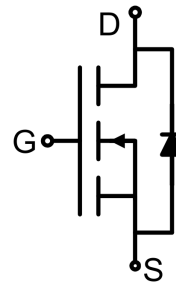
- DC/DC Converter
- Ideal for high-frequency switching and synchronous rectification

## Package

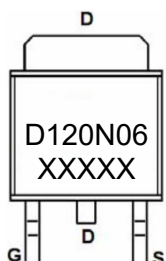


TO-252AB

## Circuit diagram



## Marking



### Absolute maximum ratings (Ta=25°C unless otherwise noted)

Parameter	Symbol	Value	Unit
Drain-Source Voltage	V <sub>DS</sub>	60	V
Gate-Source Voltage	V <sub>GS</sub>	±20	V
Continuous Drain Current	I <sub>D</sub>	120	A
Drain Current-Continuous(T <sub>C</sub> =100 °C )	I <sub>D</sub> (100 °C)	100	A
Pulsed Drain Current	I <sub>DM</sub>	480	A
Power Dissipation	P <sub>D</sub>	180	W
Thermal Resistance,Junction-to-Case	R <sub>θJC</sub>	0.83	°C/W
Single pulse avalanche energy	E <sub>AS</sub>	500	mJ
Junction Temperature	T <sub>J</sub>	150	°C
Storage Temperature	T <sub>STG</sub>	-55 ~ +150	°C

### Electrical characteristics (T<sub>A</sub>=25 °C, unless otherwise noted)

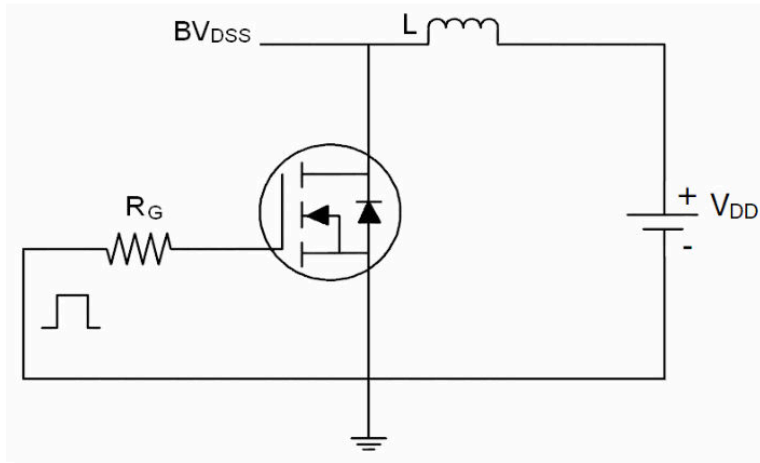
Parameter	Symbol	Test Condition	Min.	Typ.	Max.	Unit
<b>Static Characteristics</b>						
Drain-source breakdown voltage	V <sub>(BR)DSS</sub>	V <sub>GS</sub> = 0V, I <sub>D</sub> =250μA	60			V
Zero gate voltage drain current	I <sub>DSS</sub>	V <sub>DS</sub> =60V, V <sub>GS</sub> = 0V			1	μA
Gate-body leakage current	I <sub>GSS</sub>	V <sub>GS</sub> =±20V, V <sub>DS</sub> = 0V			±100	nA
Gate threshold voltage	V <sub>GS(th)</sub>	V <sub>DS</sub> =V <sub>GS</sub> , I <sub>D</sub> =250μA	1.0		2.4	V
Drain-source on-resistance <sup>1)</sup>	R <sub>DS(on)</sub>	V <sub>GS</sub> =10V, I <sub>D</sub> =60A		3.5	4.0	mΩ
		V <sub>GS</sub> =4.5V, I <sub>D</sub> =60A		4.0	5.0	
Forward transconductance <sup>1)</sup>	g <sub>FS</sub>	V <sub>DS</sub> =10V, I <sub>D</sub> =60A	40			S
<b>Dynamic characteristics<sup>2)</sup></b>						
Input Capacitance	C <sub>iss</sub>	V <sub>DS</sub> =30V, V <sub>GS</sub> =0V, f =1MHz		4000		pF
Output Capacitance	C <sub>oss</sub>			680		
Reverse Transfer Capacitance	C <sub>rss</sub>			23		
Total Gate Charge	Q <sub>g</sub>	V <sub>DS</sub> =30V, V <sub>GS</sub> =10V, I <sub>D</sub> =60A		67		nC
Gate-Source Charge	Q <sub>gs</sub>			12		
Gate-Drain Charge	Q <sub>gd</sub>			8.5		
Turn-on delay time	t <sub>d(on)</sub>	V <sub>DD</sub> =30V, V <sub>GS</sub> =10V, I <sub>D</sub> =60A, R <sub>GEN</sub> =4.7Ω		11		nS
Turn-on rise time	t <sub>r</sub>			5		
Turn-off delay time	t <sub>d(off)</sub>			56		
Turn-off fall time	t <sub>f</sub>			12		
<b>Source-Drain Diode characteristics</b>						
Diode Forward Current <sup>1)</sup>	I <sub>S</sub>				120	A
Diode Forward voltage	V <sub>DS</sub>	V <sub>GS</sub> =0V, I <sub>S</sub> =120A			1.2	V
Reverse Recovery Time	t <sub>rr</sub>	T <sub>J</sub> = 25°C, I <sub>F</sub> = I <sub>S</sub> di/dt = 100A/μs <sup>1)</sup>		48		nS
Reverse Recovery Charge	Q <sub>rr</sub>			60		nC

Notes:

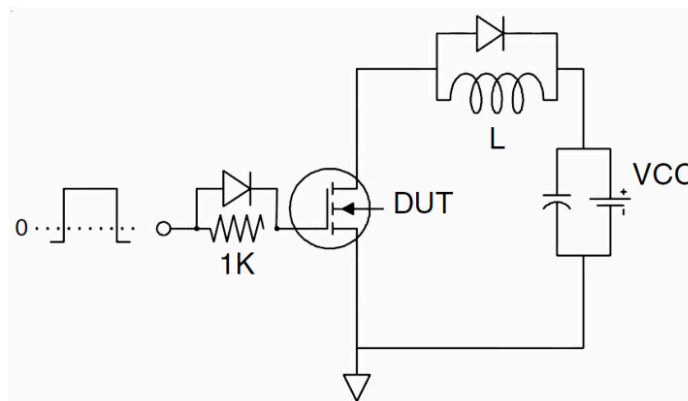
- 1) Pulse Test: Pulse Width < 300μs, Duty Cycle ≤2%.
- 2) Guaranteed by design, not subject to production testing.

## Test Circuit

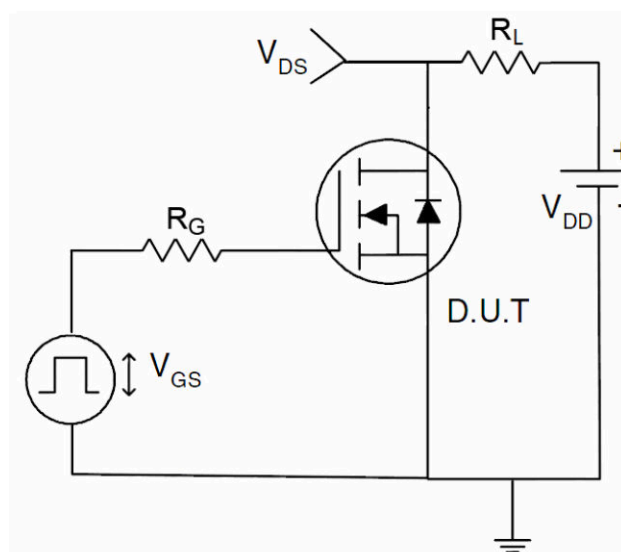
### 1) $E_{AS}$ test Circuit



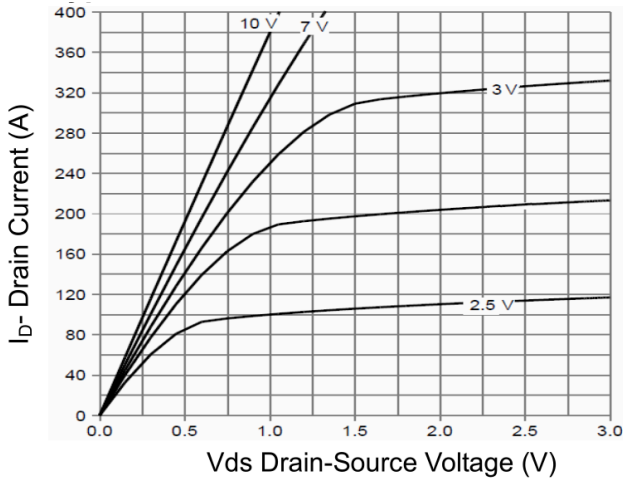
### 2) Gate charge test Circuit



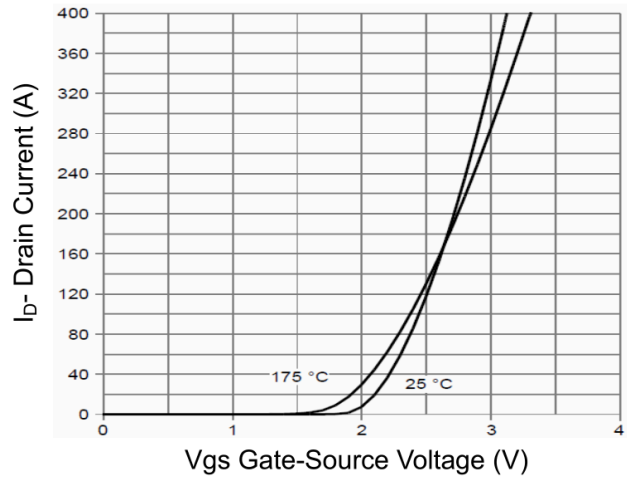
### 3) Switch Time Test Circuit



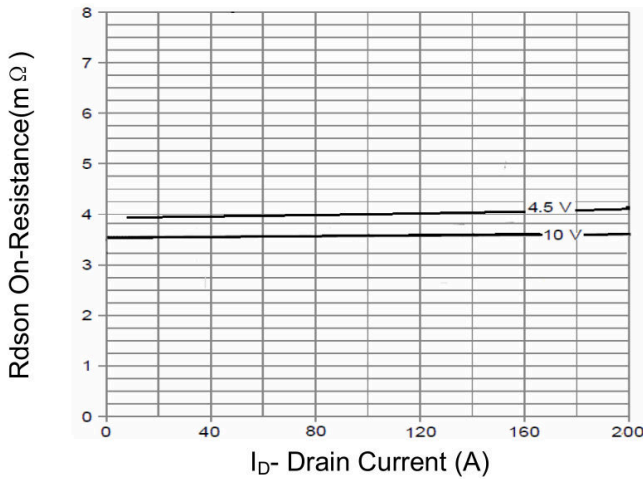
## Typical Characteristics



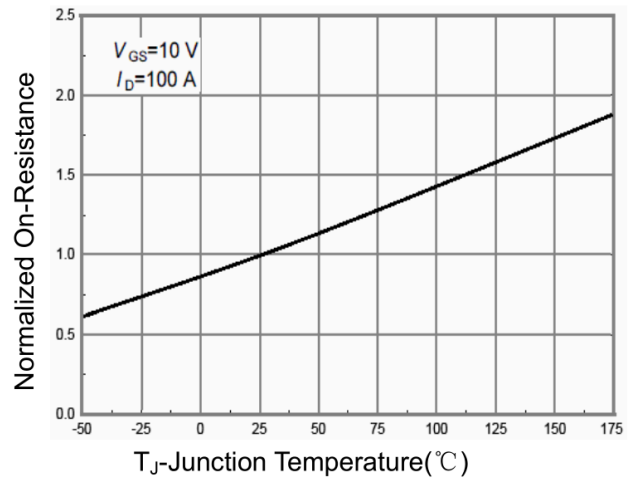
**Figure 1 Output Characteristics**



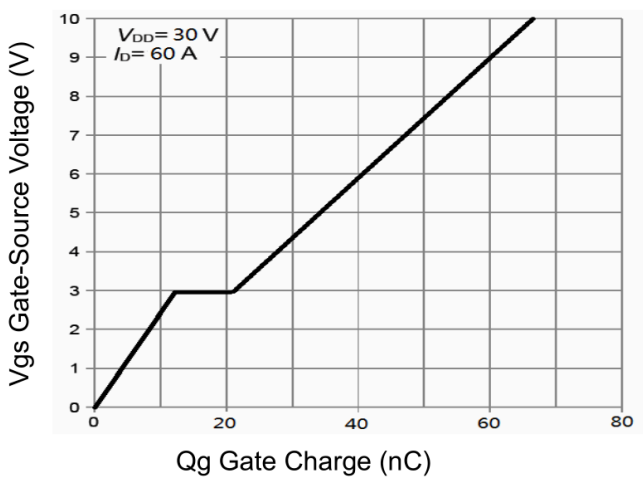
**Figure 2 Transfer Characteristics**



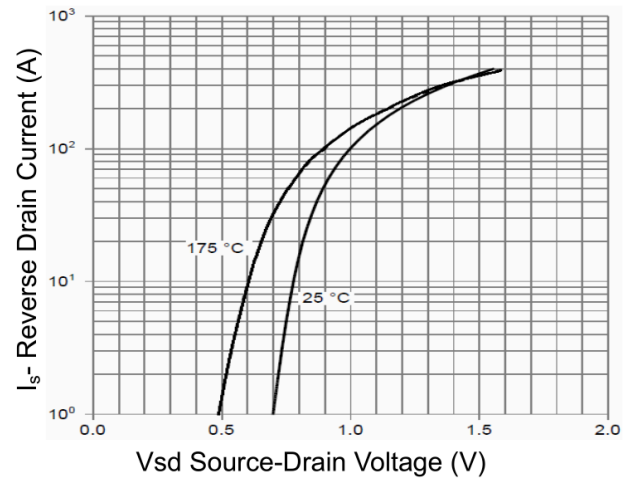
**Figure 3 Rdson- Drain Current**



**Figure 4 Rdson-Junction Temperature**

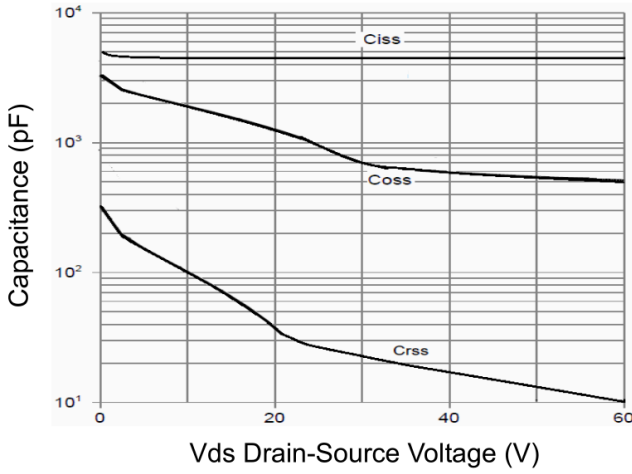


**Figure 5 Gate Charge**

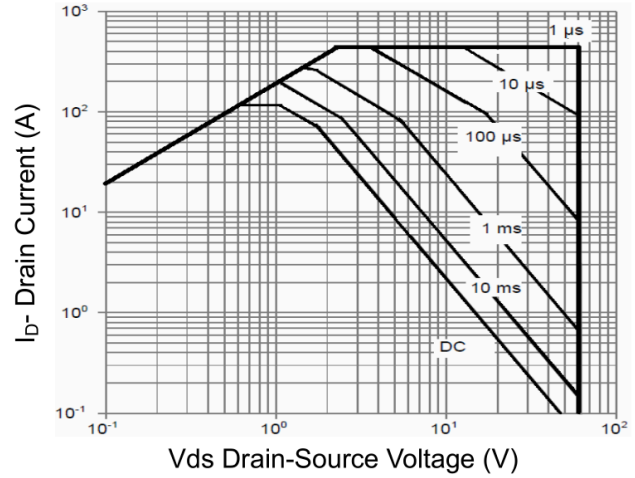


**Figure 6 Source- Drain Diode Forward**

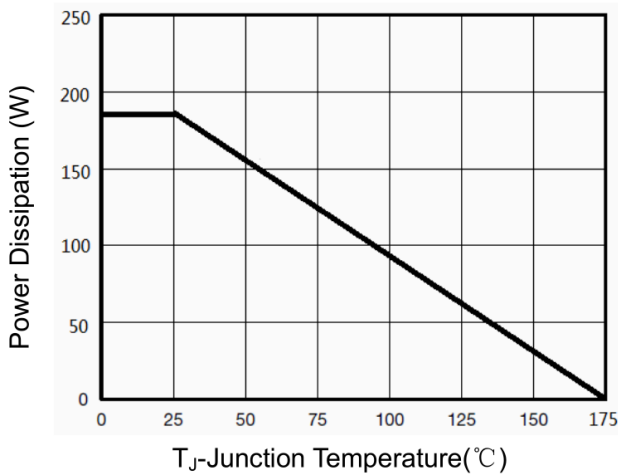
## Typical Characteristics



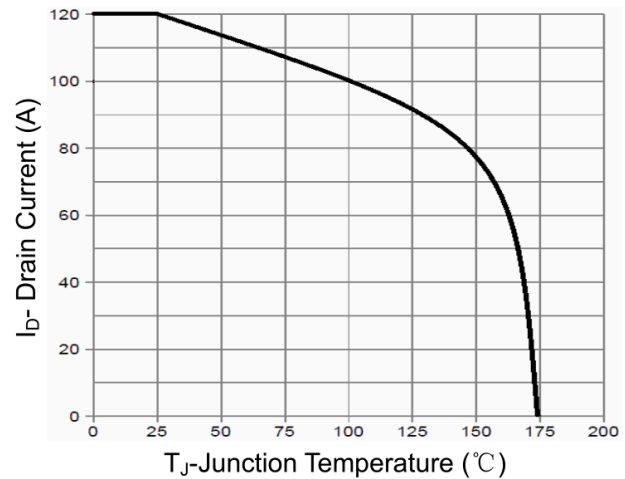
**Figure 7 Capacitance vs Vds**



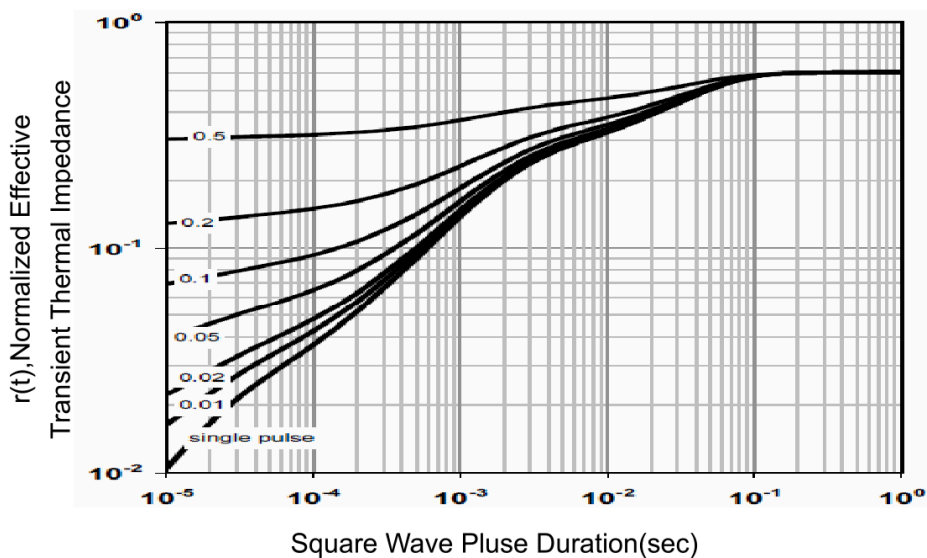
**Figure 8 Safe Operation Area**



**Figure 9 Power De-rating**

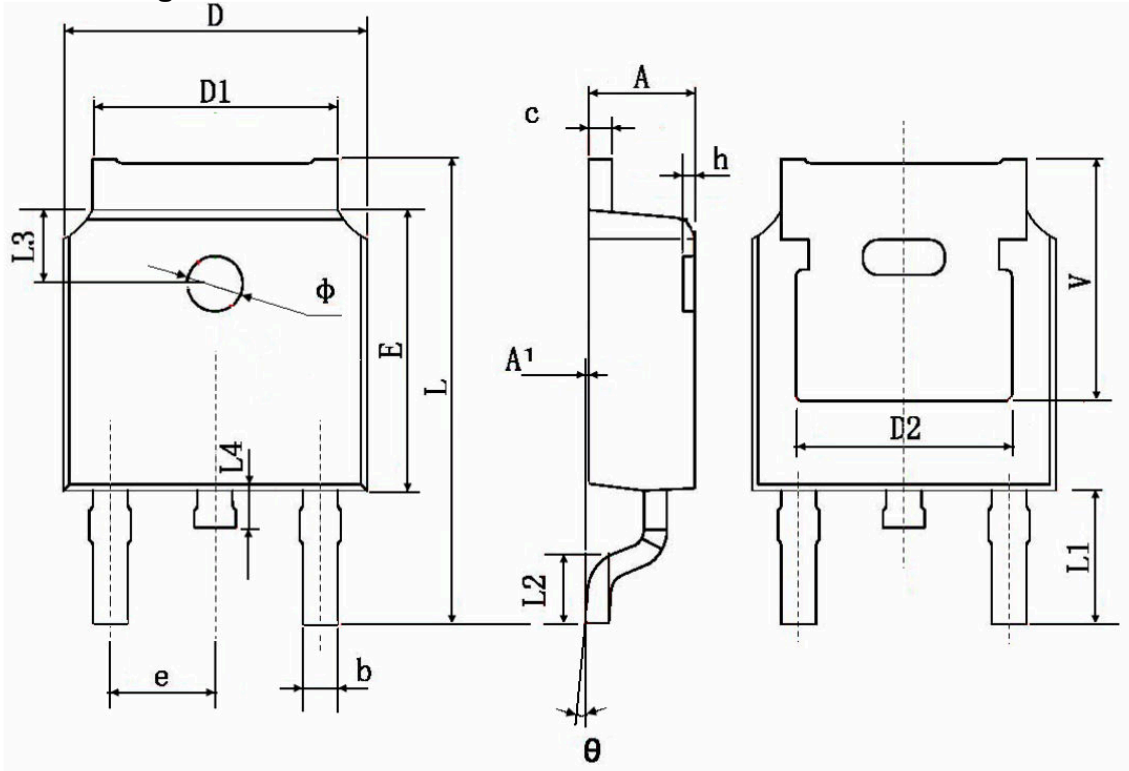


**Figure 10 Current De-rating**



**Figure 11 Normalized Maximum Transient Thermal Impedance**

### TO-252AB Package Information



Symbol	Dimensions In Millimeters		Dimensions In Inches	
	Min.	Max.	Min.	Max.
A	2.200	2.400	0.087	0.094
A1	0.000	0.127	0.000	0.005
b	0.660	0.860	0.026	0.034
c	0.460	0.580	0.018	0.023
D	6.500	6.700	0.256	0.264
D1	5.100	5.460	0.201	0.215
D2	4.830 TYP.		0.190 TYP.	
E	6.000	6.200	0.236	0.244
e	2.186	2.386	0.086	0.094
L	9.800	10.400	0.386	0.409
L1	2.900 TYP.		0.114 TYP.	
L2	1.400	1.700	0.055	0.067
L3	1.600 TYP.		0.063 TYP.	
L4	0.600	1.000	0.024	0.039
Φ	1.100	1.300	0.043	0.051
θ	0°	8°	0°	8°
h	0.000	0.300	0.000	0.012
V	5.350 TYP.		0.211 TYP.	