

### Product Summary

$V_{(BR)DSS}$	$R_{DS(on)TYP}$	$I_D@25^\circ C$
1700V	40mΩ@18V	60A

### Feature

- High Blocking Voltage with Low On-Resistance
- High Speed Switching with Low Capacitance
- Easy to Parallel and Simple to Drive

### Application

- Switch mode power supplies
- Solar inverters
- Pulsed power applications
- High voltage DC/DC converters

### Package

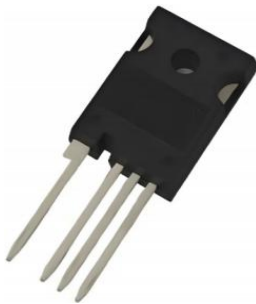

TO-247-4L

### Marking

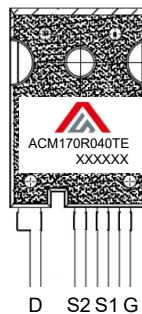

D S2 S1 G

### Circuit diagram

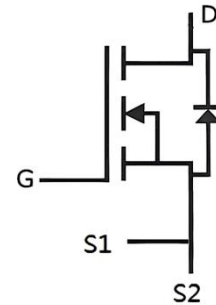

### Absolute maximum ratings ( $T_C=25^\circ C$ unless otherwise noted)

Parameter	Symbol	Test Condition	Value	Unit
Drain-Source Voltage	$V_{DSmax}$	$V_{GS} = 0V, I_D = 100\mu A$	1700	V
Gate-Source Voltage	$V_{GSmax}$		-10/+23	V
Gate-Source Voltage	$V_{GSOP}$	Recommended operational values	-5/+18	V
Continuous Drain Current	$I_D$	$V_{GS} = 18V$	60	A
	$I_D$	$V_{GS} = 18V, T_C = 100^\circ C$	42	A
Pulsed Drain Current	$I_{D,pulse}$	Pulse with $t_p$ limited by $T_{Jmax}$	210	A
Power Dissipation	$P_D$	$T_J = 175^\circ C$	375	W
Thermal Resistance (Typ)	$R_{\theta JC}$	Junction-to-Case	0.4	$^\circ C/W$
Junction Temperature	$T_J$		-55~ +175	$^\circ C$
Storage Temperature	$T_{STG}$		-55~ +175	$^\circ C$

### Electrical characteristics (T<sub>J</sub>=25°C, unless otherwise noted)

Parameter	Symbol	Test Condition	Min.	Typ.	Max.	Unit
<b>Static Characteristics</b>						
Drain-source breakdown voltage	V <sub>(BR)DSS</sub>	V <sub>GS</sub> = 0V, I <sub>D</sub> = 100μA	1700			V
Zero gate voltage drain current	I <sub>DSS</sub>	V <sub>DS</sub> = 1700V, V <sub>GS</sub> = 0V		1	100	μA
Gate-Source leakage current	I <sub>GSS+</sub>	V <sub>DS</sub> = 0V, V <sub>GS</sub> = 23V		10	250	nA
	I <sub>GSS-</sub>	V <sub>DS</sub> = 0V, V <sub>GS</sub> = -10V				
Gate threshold voltage	V <sub>GS(th)</sub>	V <sub>DS</sub> = V <sub>GS</sub> , I <sub>D</sub> = 10mA	1.9	2.6	4	V
		V <sub>DS</sub> = V <sub>GS</sub> , I <sub>D</sub> = 10mA, T <sub>J</sub> = 175°C		1.9		
Drain-source on-resistance	R <sub>DS(on)</sub>	V <sub>GS</sub> = 18V, I <sub>D</sub> = 40A		40	50	mΩ
		V <sub>GS</sub> = 18V, I <sub>D</sub> = 40A, T <sub>J</sub> = 175°C		85		
Transconductance	g <sub>fs</sub>	V <sub>GS</sub> = 20V, I <sub>D</sub> = 40A		26.7		S
		V <sub>GS</sub> = 20V, I <sub>D</sub> = 40A, T <sub>J</sub> = 175°C		23		
<b>Dynamic characteristics</b>						
Input Capacitance	C <sub>iss</sub>	V <sub>DS</sub> = 1000V, V <sub>GS</sub> = 0V V <sub>AC</sub> = 25mV, f = 1MHz		2840		pF
Output Capacitance	C <sub>oss</sub>			101		
Reverse Transfer Capacitance	C <sub>rss</sub>			7.9		
C <sub>oss</sub> Stored Energy	E <sub>oss</sub>			50.4		
Total Gate Charge	Q <sub>g</sub>	V <sub>DS</sub> = 1000V, V <sub>GS</sub> = -5V/18V I <sub>D</sub> = 40A		140		nC
Gate-Source Charge	Q <sub>gs</sub>			43		
Gate-Drain Charge	Q <sub>gd</sub>			17		
Internal Gate Resistance	R <sub>G(int)</sub>	V <sub>AC</sub> = 25mV, f = 1MHz		2.04		Ω
Turn-on delay time	t <sub>d(on)</sub>	V <sub>DS</sub> = 1000V, V <sub>GS</sub> = -5V/18V I <sub>D</sub> = 40A, R <sub>G(ext)</sub> = 2.5Ω, R <sub>L</sub> = 25Ω		26		nS
Turn-on rise time	t <sub>r</sub>			25		
Turn-off delay time	t <sub>d(off)</sub>			50		
Turn-off fall time	t <sub>f</sub>			15		
Turn-on Switching Energy	E <sub>on</sub>	V <sub>DS</sub> = 1000V, V <sub>GS</sub> = -5V/18V I <sub>D</sub> = 40A, R <sub>G(ext)</sub> = 2.5Ω, L = 100μH		1050		μJ
Turn-off Switching Energy	E <sub>off</sub>			243		
<b>Source-Drain Diode characteristics</b>						
Diode Forward voltage	V <sub>SD</sub>	V <sub>GS</sub> = -5V, I <sub>SD</sub> = 20A		4.0		V
		V <sub>GS</sub> = -5V, I <sub>SD</sub> = 20A, T <sub>J</sub> = 175°C		3.5		
Reverse Recovery Time	T <sub>rr</sub>	V <sub>R</sub> = 1000V, I <sub>SD</sub> = 40A		31		nS
Reverse Recovery Charge	Q <sub>rr</sub>			94		nC
Peak Reverse Recovery Current	I <sub>rrm</sub>			5.2		A

## Typical Characteristics

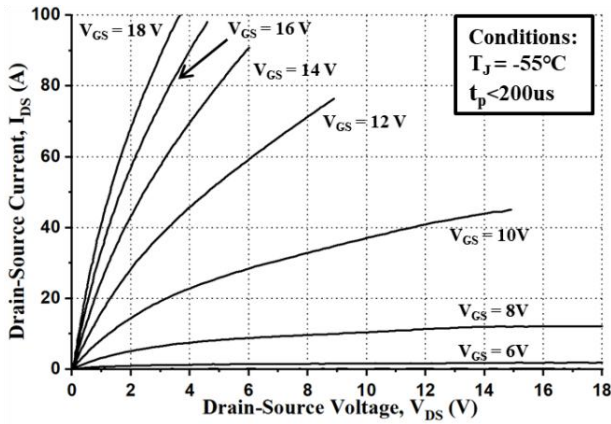

Figure 1. Output Characteristics  $T_J = -55^\circ\text{C}$

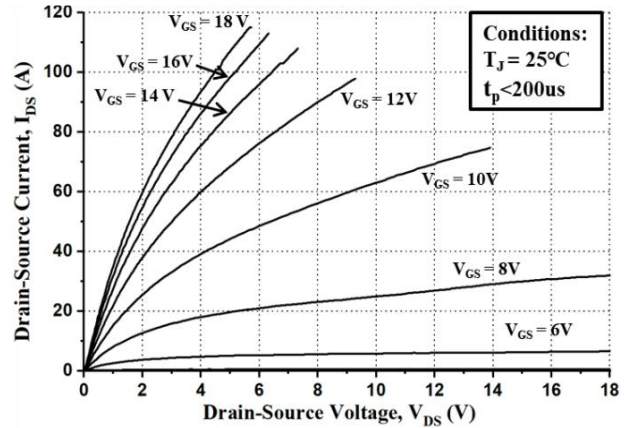

Figure 2. Output Characteristics  $T_J = 25^\circ\text{C}$

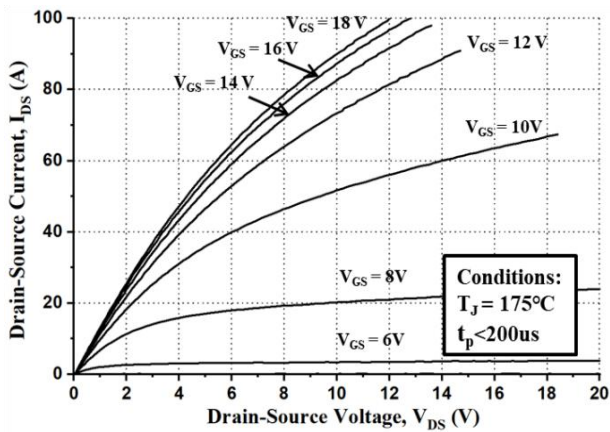

Figure 3. Output Characteristics  $T_J = 175^\circ\text{C}$

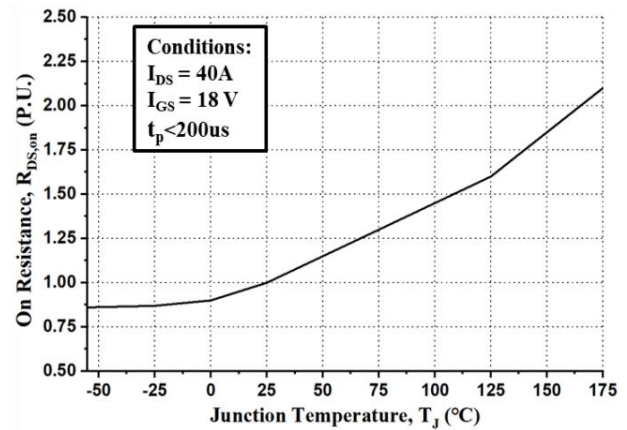

Figure 4. Normalized On-Resistance vs. Temperature

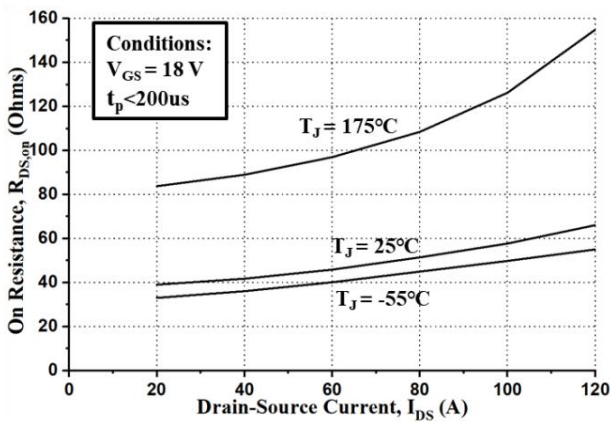

Figure 5. On-Resistance vs. Drain Current  
For Various Temperatures

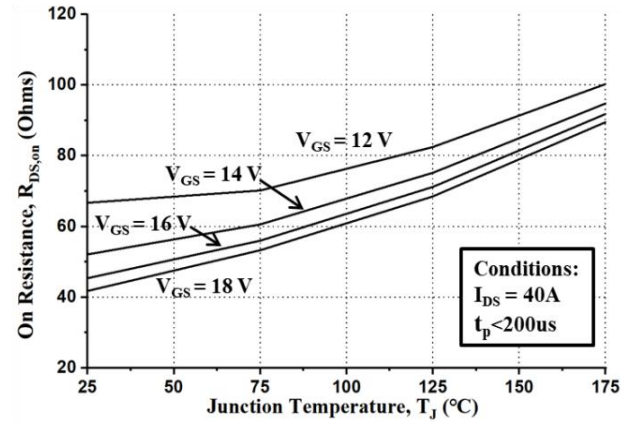

Figure 6. On-Resistance vs. Temperature  
For Various Gate Voltage

## Typical Characteristics

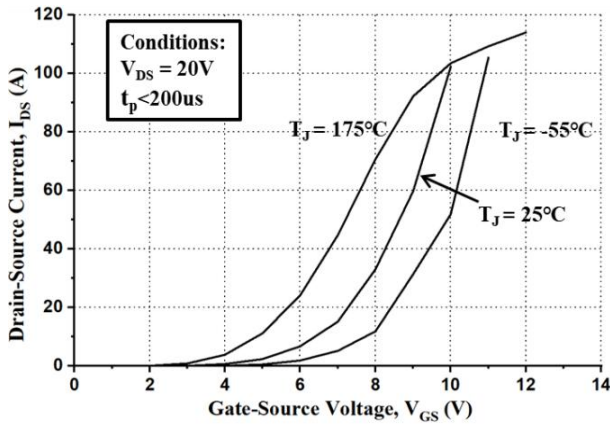

Figure 7. Transfer Characteristic for Various Junction Temperatures

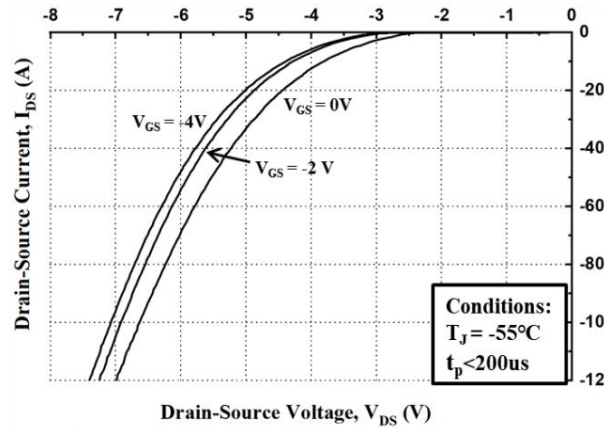

Figure 8. Body Diode Characteristic at -55°C

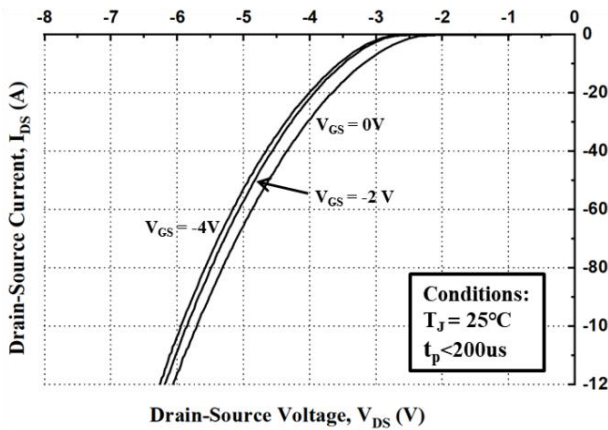

Figure 9. Body Diode Characteristic at 25°C

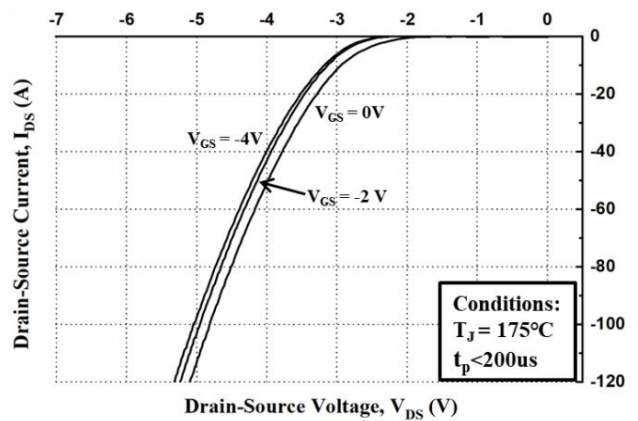

Figure 10. Body Diode Characteristic at 175°C

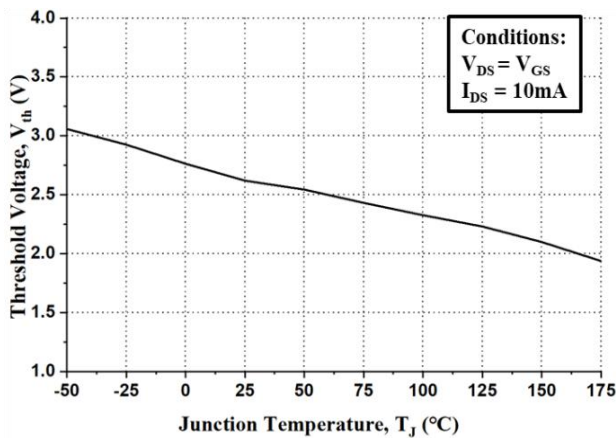

Figure 11. Threshold Voltage vs. Temperature

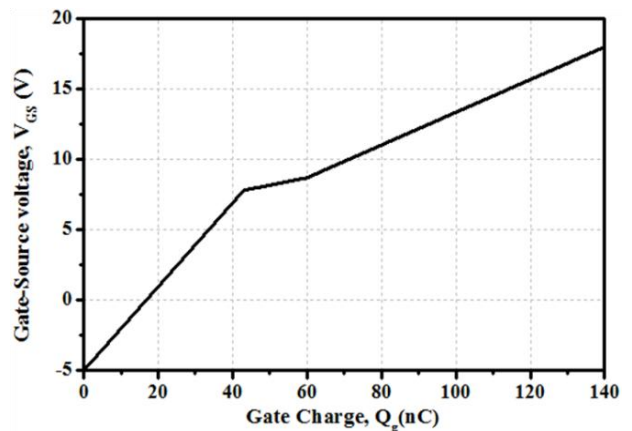

Figure 12. Gate Charge Characteristics

## Typical Characteristics

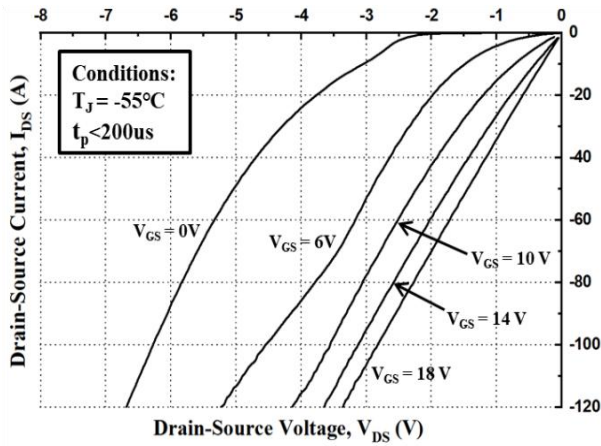

Figure 13. 3rd Quadrant Characteristic at -55°C

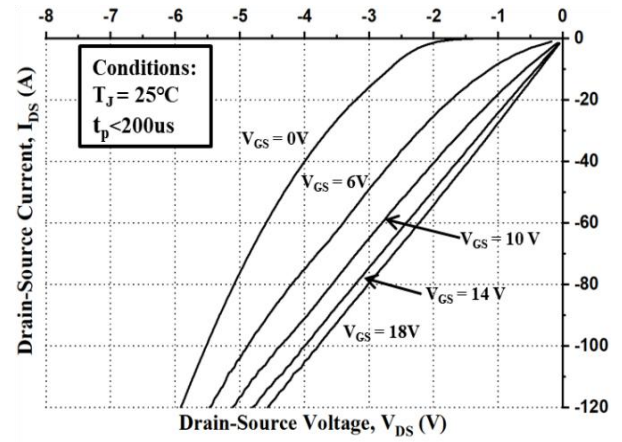

Figure 14. 3rd Quadrant Characteristic at 25°C

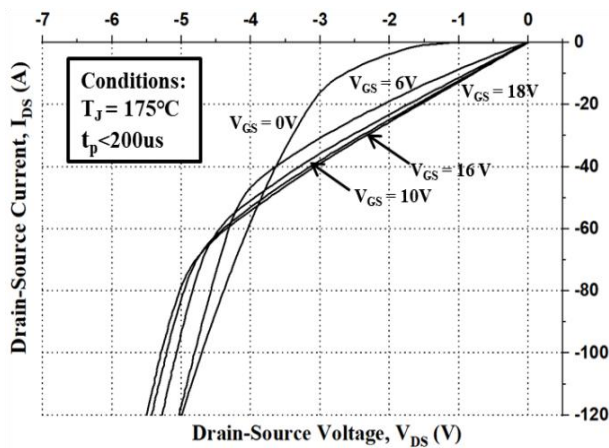

Figure 15. 3rd Quadrant Characteristic at 175°C

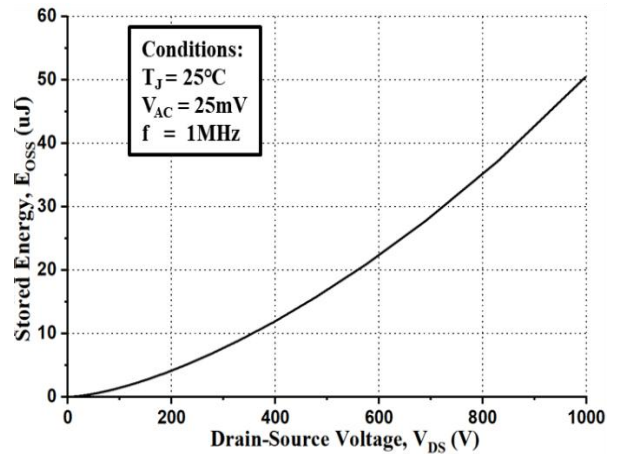

Figure 16. Output Capacitor Stored Energy

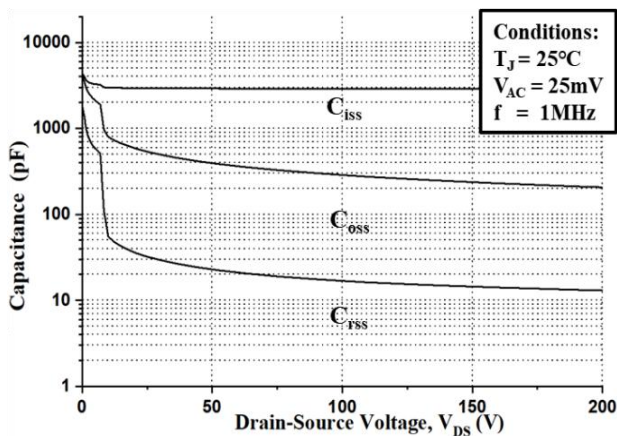

Figure 17. Capacitances vs. Drain-Source Voltage (0 - 200V)

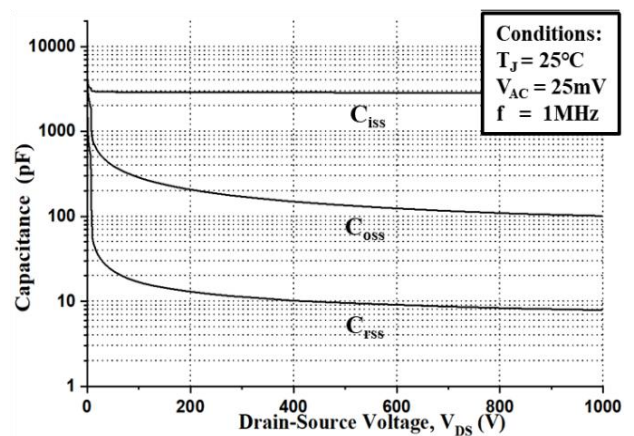

Figure 18. Capacitances vs. Drain-Source Voltage (0 - 1000V)

### Typical Characteristics

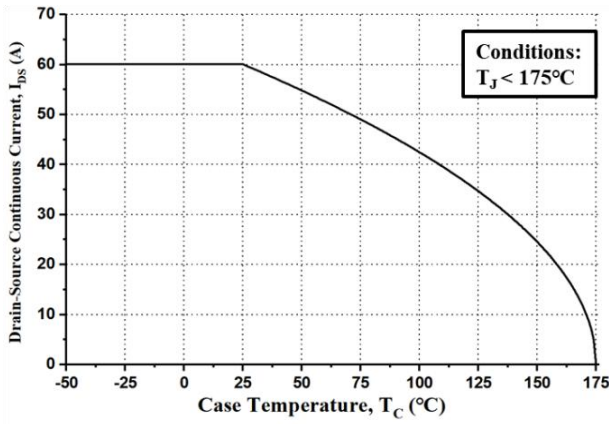

Figure 19. Continuous Drain Current Derating vs. Case Temperature

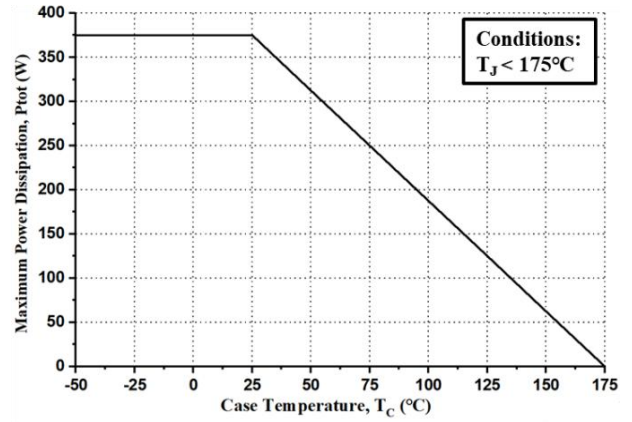

Figure 20. Maximum Power Dissipation Derating vs. Case Temperature

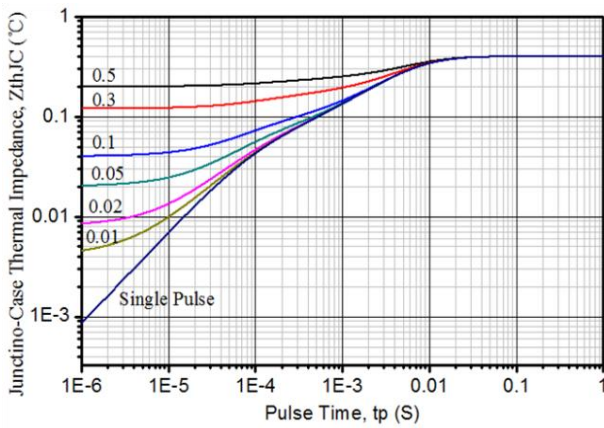

Figure 21. Transient Thermal Impedance (Junction - Case)

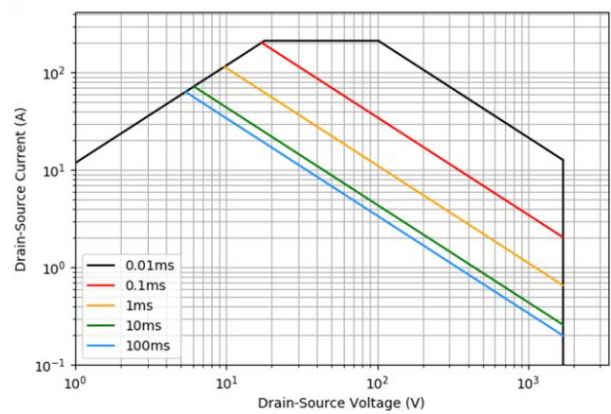
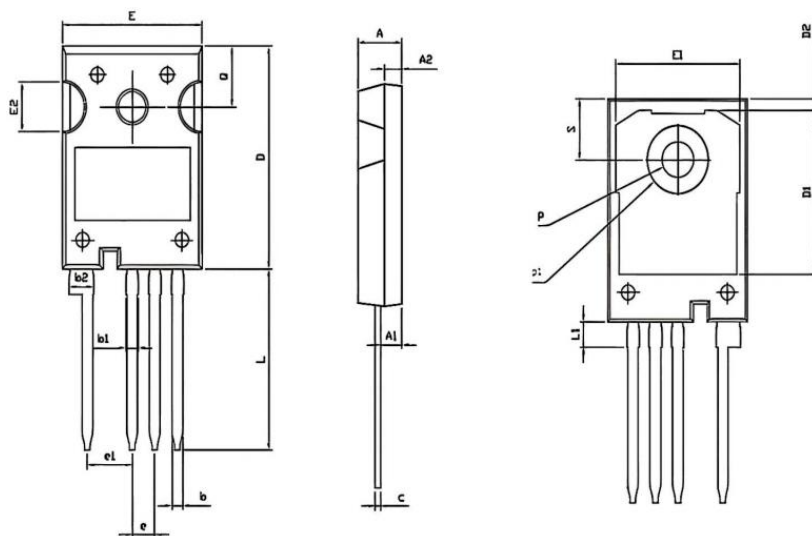

Figure 22. Safe Operating Area

### TO-247-4L Package Information



Symbol	Dimensions In Millimeters		Dimensions In Inches	
	Min.	Max.	Min.	Max.
A	4.800	5.200	0.189	0.205
A1	2.250	2.550	0.089	0.100
A2	1.850	2.150	0.073	0.085
b	1.050	1.350	0.041	0.053
b1	1.000	1.600	0.039	0.063
b2	2.350	2.950	0.093	0.116
c	0.500	0.700	0.020	0.028
D	22.290	22.790	0.878	0.897
D1	16.000	17.000	0.630	0.669
D2	0.970	1.370	0.038	0.054
e	2.340	2.740	0.092	0.108
e1	4.880	5.280	0.192	0.208
E	15.600	16.000	0.614	0.630
E1	13.500	14.500	0.531	0.571
E2	4.800	5.200	0.189	0.205
L	18.080	18.680	0.712	0.735
L1	2.380	2.780	0.094	0.109
ΦP	3.500	3.700	0.138	0.146
ΦP1	6.600	7.600	0.260	0.299
Q	6.000	6.300	0.236	0.248
S	6.000	6.300	0.236	0.248