

Product Summary

$V_{(BR)DSS}$	$R_{DS(on)MAX}$	$I_D@25^\circ C$
650V	36mΩ@10V	70A

Feature

- New technology for high voltage device
- Ultra low on-resistance and ultra low conduction losses
- Ultra Low Gate Charge cause lower driving requirements
- Diode reverse recovery speed is super fast

Application

- Power factor correction (PFC)
- Switched mode power supplies(SMPS)
- Uninterruptible Power Supply (UPS)
- On-board charger(OBC)

Package

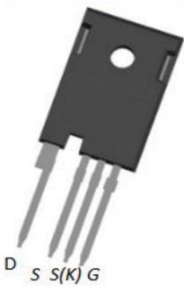

TO-247-4L

Circuit diagram

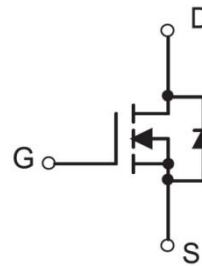

Marking

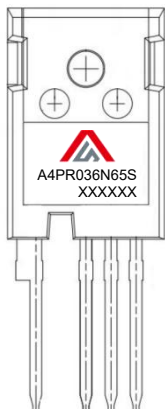

Absolute maximum ratings ($T_C=25^\circ\text{C}$ unless otherwise noted)

Parameter	Symbol	Test Condition	Value	Unit
Drain-Source Voltage	V_{DS}	$V_{GS} = 0V$	650	V
Gate-Source Voltage	V_{GS}	$V_{DS}=0V, AC (f>1 \text{ Hz})$	± 30	V
	V_{GS}	$V_{DS}=0V, DC$	± 20	V
Continuous Drain Current	$I_D (DC)$	$T_C=25^\circ\text{C}$	70	A
	$I_D (DC)$	$T_C=100^\circ\text{C}$	49	A
Pulsed drain current ¹⁾	$I_{DM} (\text{pulse})$		210	A
Power Dissipation	P_D	$T_C=25^\circ\text{C}$	488	W
Single pulse avalanche energy ²⁾	E_{AS}		784	mJ
Thermal Resistance (Maximum)	$R_{\theta JC}$	Junction-to-Case	0.31	$^\circ\text{C/W}$
Junction Temperature	T_J		-55~ +175	$^\circ\text{C}$
Storage Temperature	T_{STG}		-55~ +175	$^\circ\text{C}$

Electrical characteristics ($T_A=25^\circ\text{C}$, unless otherwise noted)

Parameter	Symbol	Test Condition	Min.	Typ.	Max.	Unit
Static Characteristics						
Drain-source breakdown voltage	$V_{(BR)DSS}$	$V_{GS} = 0V, I_D = 1\text{mA}$	650			V
Zero gate voltage drain current	I_{DSS}	$V_{DS} = 650V, V_{GS} = 0V, T_C=25^\circ\text{C}$			10	μA
Zero gate voltage drain current	I_{DSS}	$V_{DS} = 650V, V_{GS} = 0V, T_C=125^\circ\text{C}$			600	μA
Gate-Source leakage current	I_{GSS}	$V_{GS} = \pm 20V, V_{DS} = 0V$			± 200	nA
Gate threshold voltage	$V_{GS(th)}$	$V_{DS} = V_{GS}, I_D = 3\text{mA}$	3.5	4.2	5	V
Drain-source on-resistance	$R_{DS(on)}$	$V_{GS} = 10V, I_D = 35A$		30	36	m Ω
Dynamic characteristics³⁾						
Input Capacitance	C_{iss}	$V_{DS} = 50V, V_{GS} = 0V, f = 1\text{MHz}$		7727		pF
Output Capacitance	C_{oss}			263		
Reverse Transfer Capacitance	C_{rss}			25.1		
Total Gate Charge	Q_g	$V_{DS} = 400V, V_{GS} = 10V, I_D = 40A$		125		nC
Gate-Source Charge	Q_{gs}			57		
Gate-Drain Charge	Q_{gd}			34		
Turn-on delay time	$t_{d(on)}$	$V_{DD}=380V, V_{GS}=10V, I_D = 40A, R_G=4\Omega$		54		nS
Turn-on rise time	t_r			37		
Turn-off delay time	$t_{d(off)}$			127		
Turn-off fall time	t_f			5		
Source-Drain Diode characteristics						
Diode Forward Current	I_S	$T_C=25^\circ\text{C}$			70	A
Diode Forward voltage	V_{SD}	$V_{GS} = 0V, I_{SD} = 70A, T_J=25^\circ\text{C}$		1.0	1.2	V
Reverse Recovery Time	t_{rr}	$I_F = 40A, T_J=25^\circ\text{C}$ $di/dt=100A/\mu\text{s}$		185		nS
Reverse Recovery Charge	Q_{rr}			1.6		μC
Peak Reverse Recovery Current	I_{rrm}			16		A

Notes:

- 1) Repetitive Rating: Pulse width limited by maximum junction temperature
- 2) $T_J=25^\circ\text{C}, V_{DD}=50V, V_G=10V, R_G=25\Omega$
- 3) Guaranteed by design, not subject to production testing.

Typical Characteristics

Figure1. Safe operating area

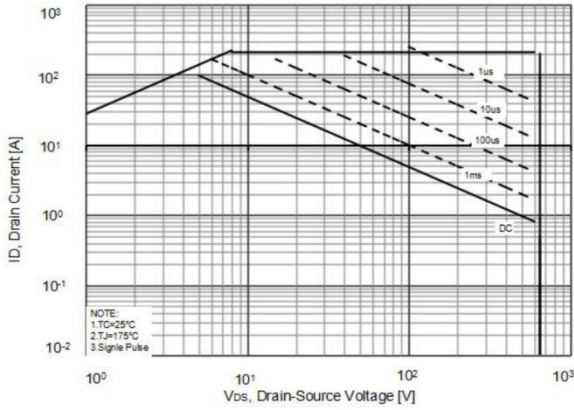

Figure2. Source-Drain Diode Forward Voltage

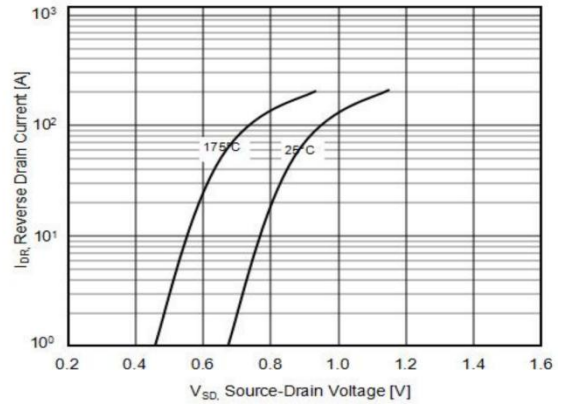

Figure3. Output characteristics (25°C)

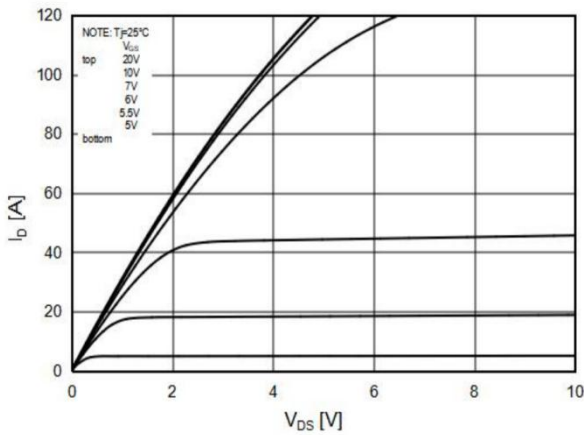

Figure4. Transfer characteristics

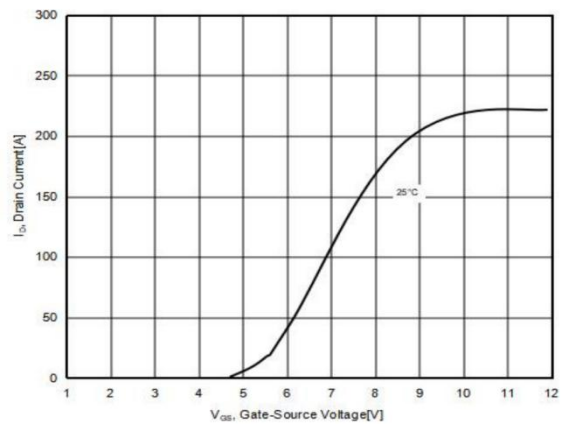

Figure5. Static drain-source on resistance

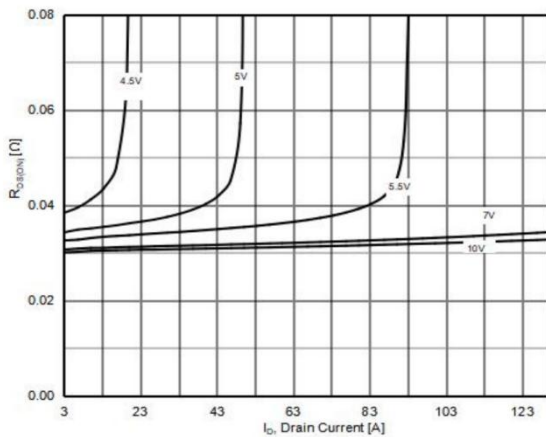
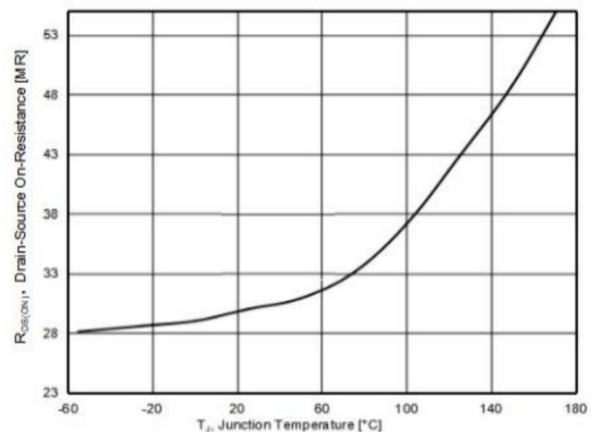

Figure6. $R_{DS(ON)}$ vs Junction Temperature



Typical Characteristics

Figure7. BV_{DSS} vs Junction Temperature

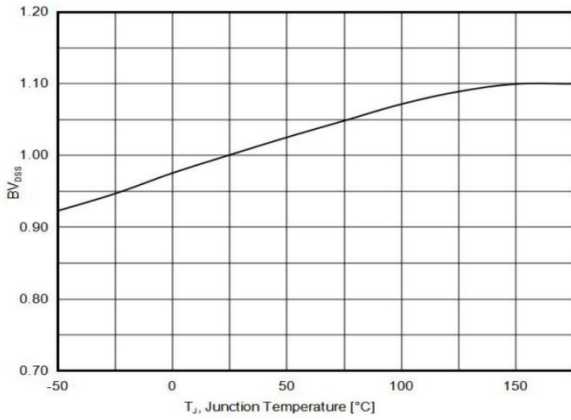

Figure8. Maximum I_D vs Junction Temperature

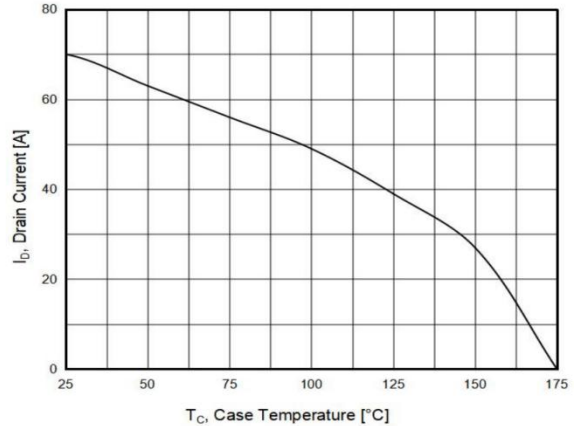

Figure9. Gate charge waveforms

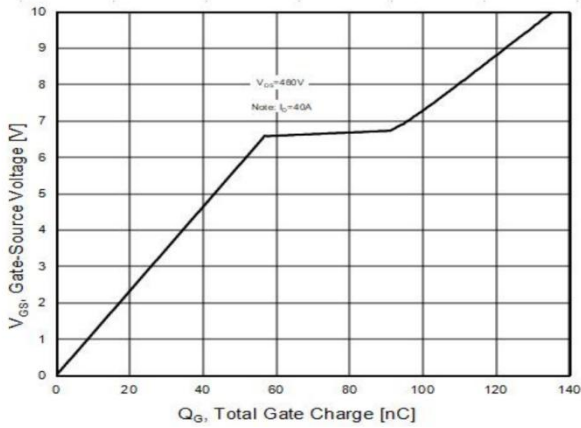

Figure10. Capacitance

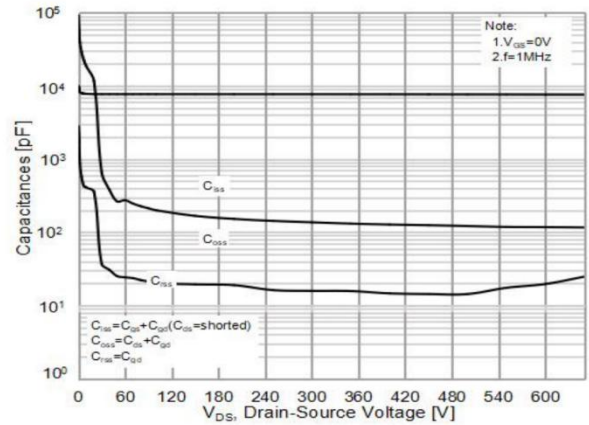
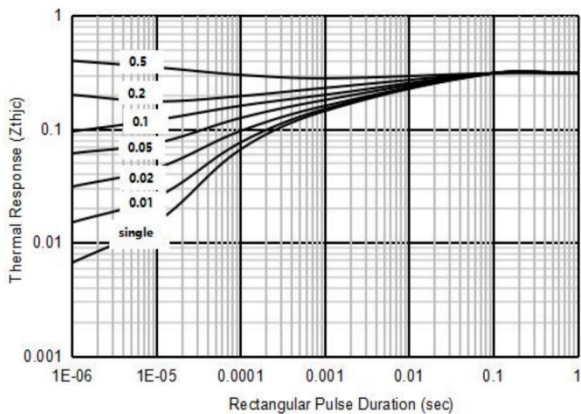
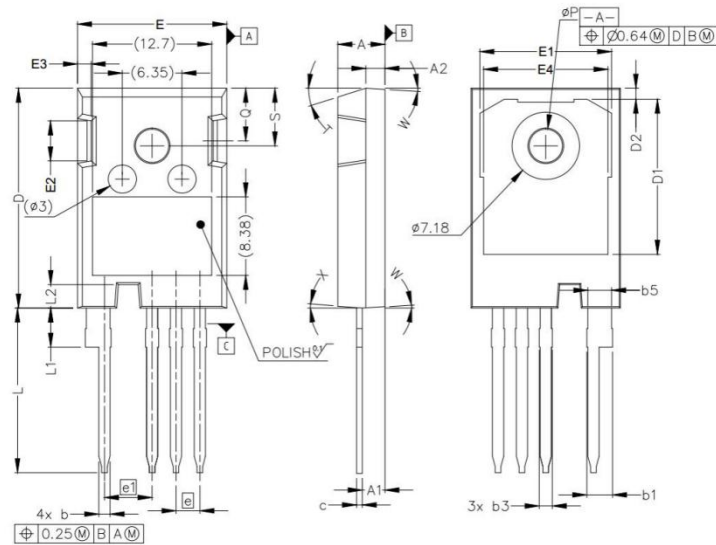

Figure11. Transient Thermal Impedance



TO-247-4L Package Information



Symbol	Dimensions In Millimeters		Dimensions In Inches	
	Min.	Max.	Min.	Max.
A	4.830	5.210	0.190	0.205
A1	2.290	2.540	0.090	0.100
A2	1.910	2.160	0.075	0.085
b	1.070	1.330	0.042	0.052
b1	2.390	2.940	0.094	0.116
b3	1.070	1.600	0.042	0.063
b5	2.390	2.690	0.094	0.106
c	0.550	0.680	0.022	0.027
D	23.300	23.600	0.917	0.929
D1	16.250	17.650	0.640	0.695
D2	0.950	1.250	0.037	0.049
E	15.750	16.130	0.620	0.635
E1	13.100	14.150	0.516	0.557
E2	3.680	5.100	0.145	0.201
E3	1.000	1.900	0.039	0.075
E4	12.380	13.430	0.487	0.529
e	2.540 BSC		0.100 BSC	
e1	5.080 BSC		0.200 BSC	
L	17.310	17.820	0.681	0.702
L1	3.970	4.370	0.156	0.172
L2	2.350	2.650	0.093	0.104
φP	3.510	3.650	0.138	0.144
Q	5.490	6.000	0.216	0.236
S	6.040	6.300	0.238	0.248
T	17.5° REF		17.5° REF	
W	3.5° REF		3.5° REF	
X	4.0° REF		4.0° REF	