

Product Summary

$V_{(BR)DSS}$	$R_{DS(on)MAX}$	I_D
-60V	120mΩ@10V	-4.3A
	170mΩ@4.5V	

Feature

- High density cell design for ultra low $R_{DS(ON)}$
- Trench Power MV MOSFET technology
- Excellent package for good heat dissipation

Application

- DC-DC Converters
- Power management functions

Package

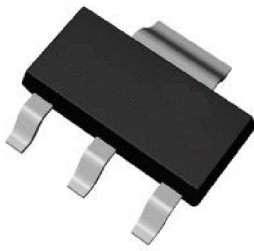

SOT-223

Circuit diagram

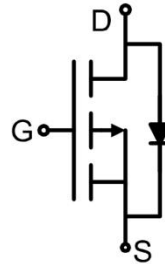

Marking



Absolute maximum ratings (Ta=25°C unless otherwise noted)

Parameter	Symbol	Value	Unit
Drain-Source Voltage	V _{DS}	-60V	V
Gate-Source Voltage	V _{GS}	±20	V
Continuous Drain Current	I _D	-4.3	A
Pulsed Drain Current	I _{DM}	-20	A
Power Dissipation	P _D	3.1	W
Thermal Resistance from Junction to Ambient	R _{θJA}	40.3	°C/W
Junction Temperature	T _J	150	°C
Storage Temperature	T _{STG}	-55 ~ +150	°C

Electrical characteristics (T_A=25 °C, unless otherwise noted)

Parameter	Symbol	Test Condition	Min.	Typ.	Max.	Unit
Static Characteristics						
Drain-source breakdown voltage	V _{(BR)DSS}	V _{GS} = 0V, I _D = -250μA	-60V			V
Zero gate voltage drain current	I _{DSS}	V _{DS} = -48V, V _{GS} = 0V			-1	μA
Gate-body leakage current	I _{GSS}	V _{GS} = ±20V, V _{DS} = 0V			±100	nA
Gate threshold voltage	V _{GS(th)}	V _{DS} = V _{GS} , I _D = -250μA	-1.0		-2.5	V
Drain-source on-resistance ¹⁾	R _{DS(on)}	V _{GS} = -10V, I _D = -4.0A		105	120	mΩ
		V _{GS} = -4.5V, I _D = -3.0A		133	170	
Dynamic characteristics²⁾						
Input Capacitance	C _{iss}	V _{DS} = -30V, V _{GS} = 0V, f = 1MHz		930		pF
Output Capacitance	C _{oss}			85		
Reverse Transfer Capacitance	C _{rss}			35		
Total Gate Charge	Q _g	V _{DS} = -30V, V _{GS} = -10V, I _D = -4A		25		nC
Gate-Source Charge	Q _{gs}			3		
Gate-Drain Charge	Q _{gd}			7		
Turn-on delay time	t _{d(on)}	V _{DD} = -30V, V _{GS} = -10V, R _L = 7.5Ω, R _{GEN} = 3Ω		8		nS
Turn-on rise time	t _r			4		
Turn-off delay time	t _{d(off)}			32		
Turn-off fall time	t _f			7		
Source-Drain Diode characteristics						
Diode Forward Current ¹⁾	I _S				-4.3	A
Diode Forward voltage	V _{DS}	V _{GS} = 0V, I _S = -4A			-1.2	V
Reverse Recovery Time	t _{rr}	T _J = 25°C, I _F = -4A		25		nS
Reverse Recovery Charge	Q _{rr}	di/dt = -100A/μs(Notes3)		31		nC

Notes:

- 1) Pulse Test: Pulse Width < 300μs, Duty Cycle ≤2%.
- 2) Guaranteed by design, not subject to production testing.

Typical Characteristics

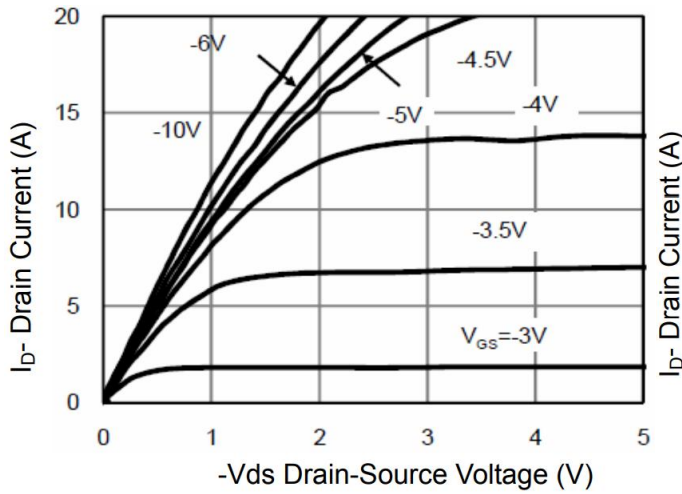

Figure 1 Output Characteristics

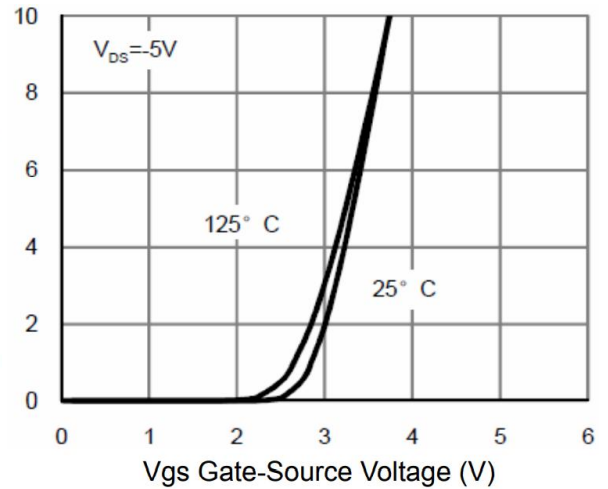

Figure 2 Transfer Characteristics

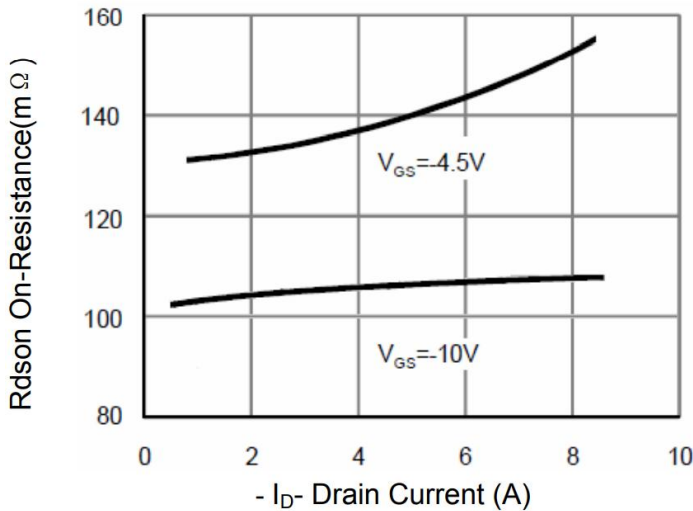

Figure 3 Rdson- Drain Current

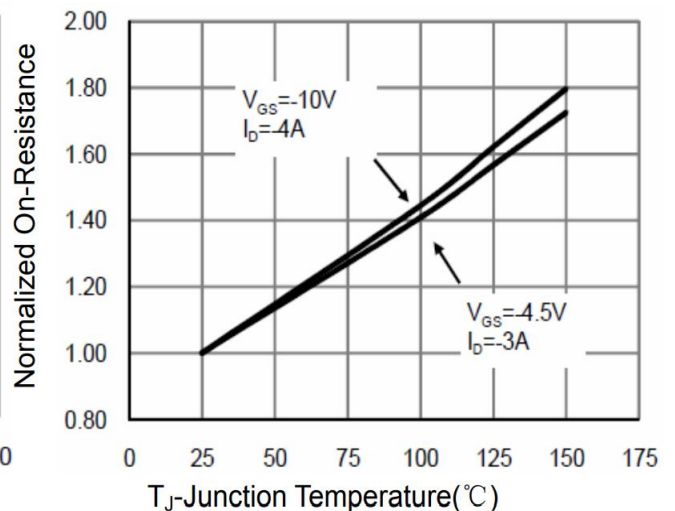

Figure 4 Rdson-Junction Temperature

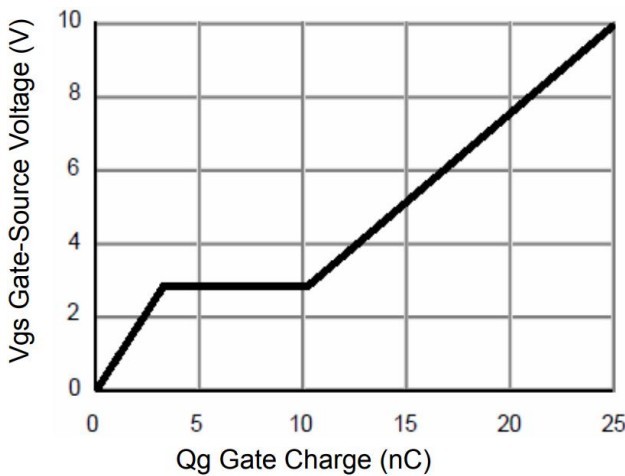

Figure 5 Gate Charge

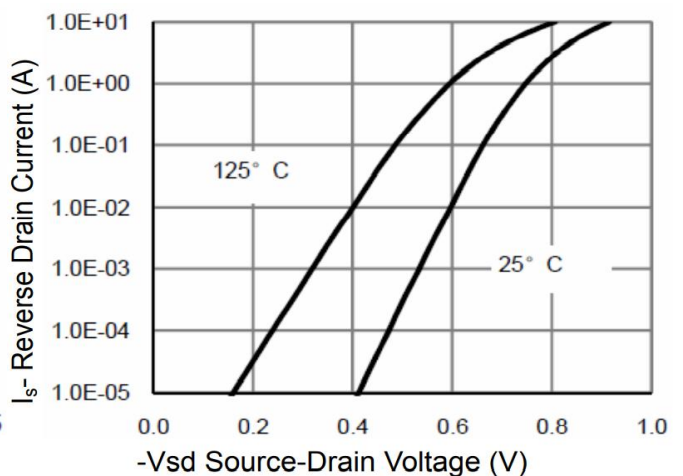

Figure 6 Source- Drain Diode Forward

Typical Characteristics

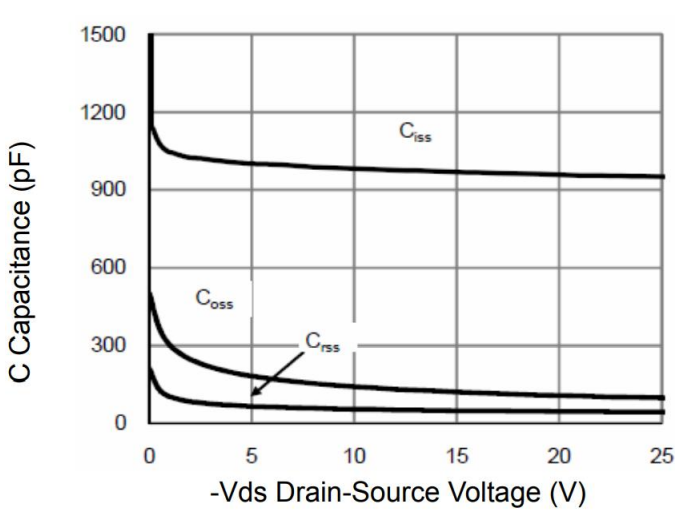

Figure 7 Capacitance vs Vds

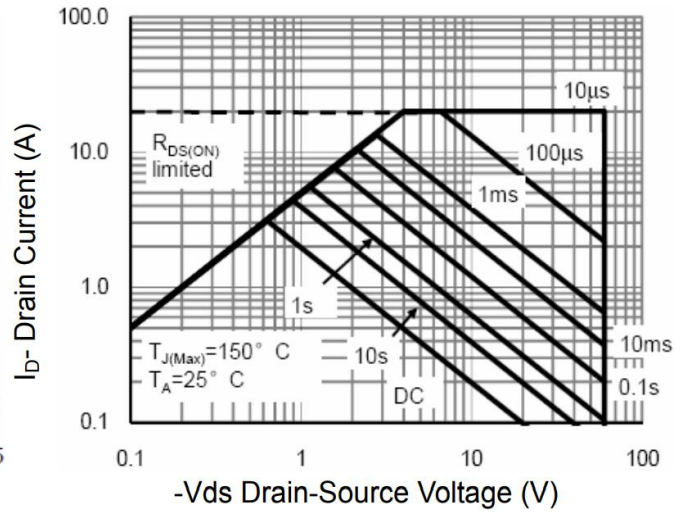

Figure 8 Safe Operation Area

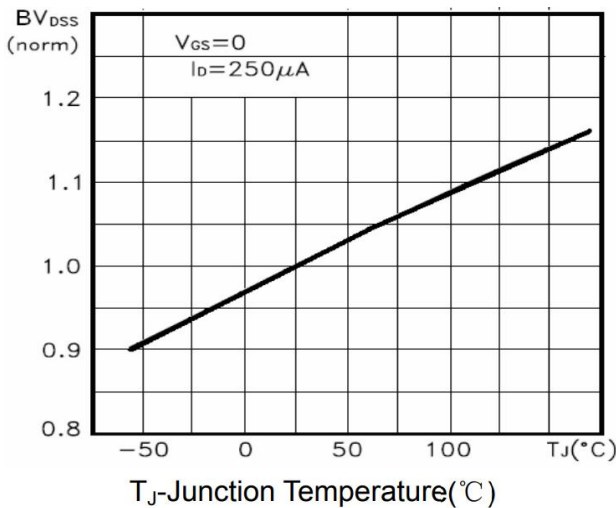

Figure 9 BVDS vs Junction Temperature

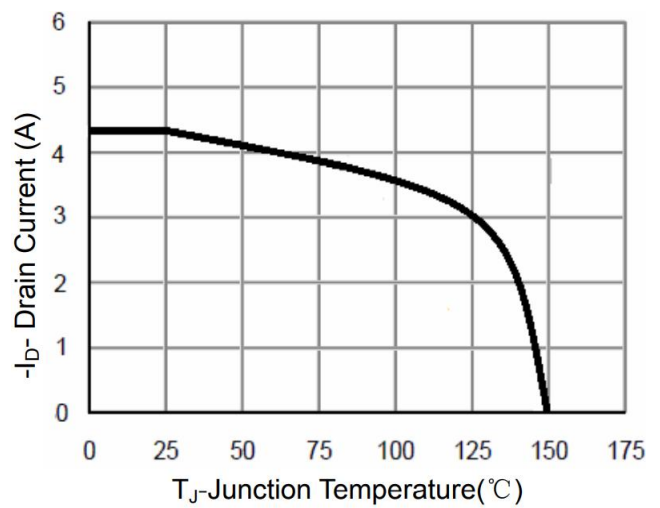

Figure 10 ID Current De-rating

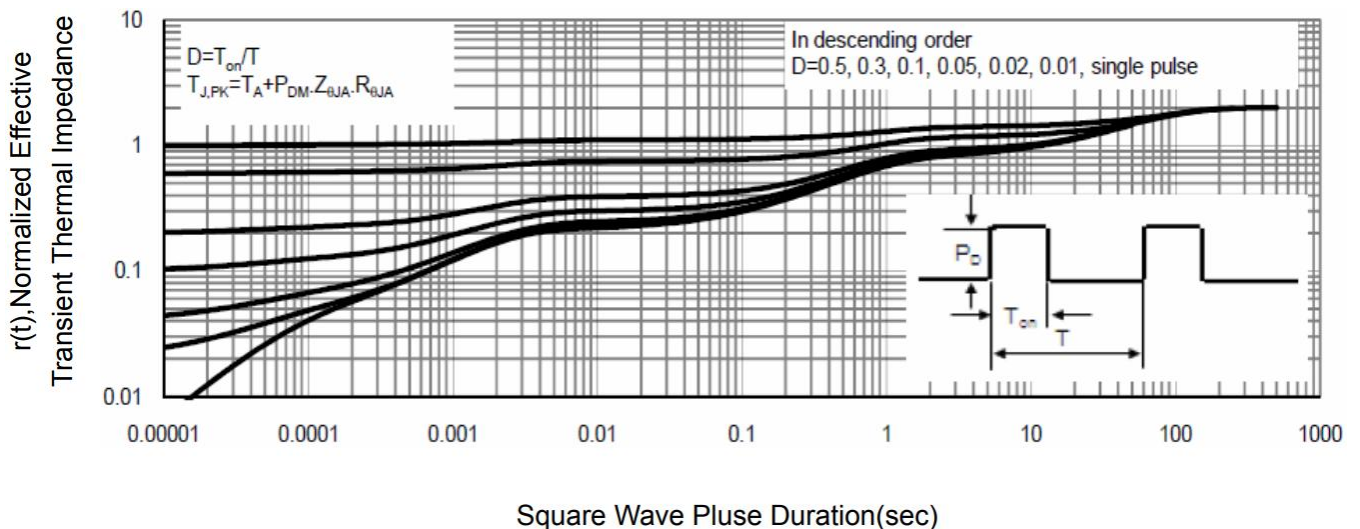
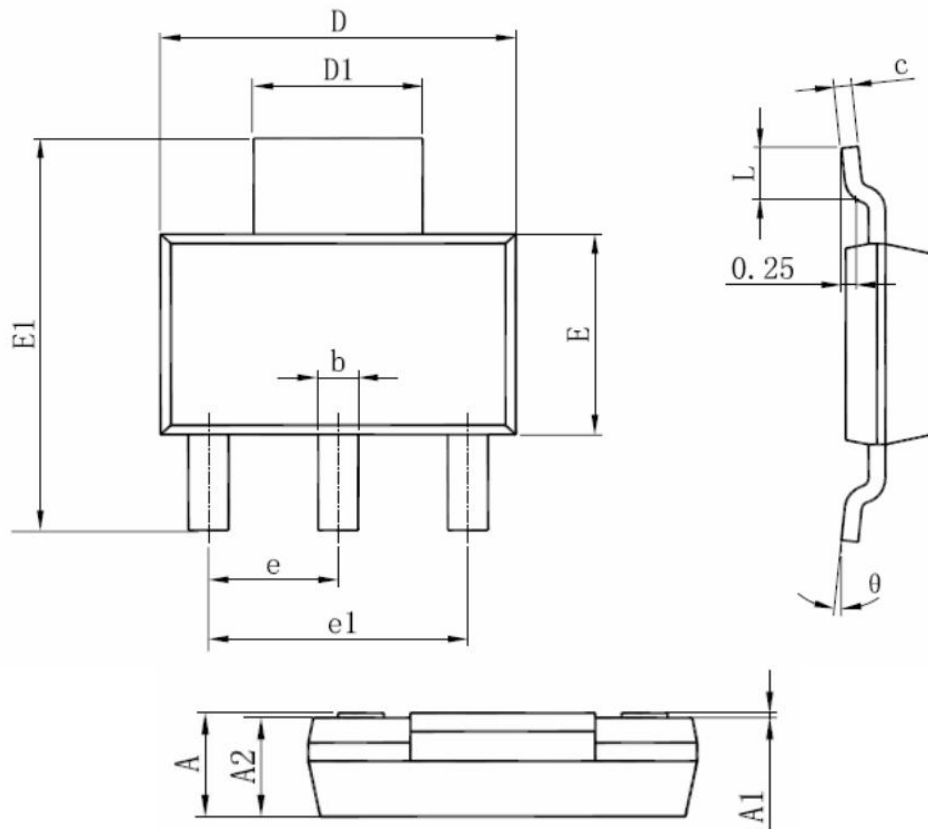

Figure 11 Normalized Maximum Transient Thermal Impedance

SOT-223 Package Information



Symbol	Dimensions In Millimeters		Dimensions In Inches	
	Min.	Max.	Min.	Max.
A	1.520	1.800	0.060	0.071
A1	0.000	0.100	0.000	0.004
A2	1.500	1.700	0.059	0.067
b	0.660	0.820	0.026	0.032
c	0.250	0.350	0.010	0.014
D	6.200	6.400	0.244	0.252
D1	2.900	3.100	0.114	0.122
E	3.300	3.700	0.130	0.146
E1	6.830	7.070	0.269	0.278
e	2.300(BSC)		0.091(BSC)	
e1	4.500	4.700	0.177	0.185
L	0.900	1.150	0.035	0.045
θ	0°	10°	0°	10°