

Product Summary

$V_{(BR)DSS}$	$R_{DS(on)MAX}$	I_D
-30V	19mΩ@-10V	-10A
	28mΩ@-4.5V	

Feature

- Trench Power LV MOSFET technology
- High density cell design for low $R_{DS(ON)}$
- High Speed switching

Application

- Battery protection
- Load switch
- Power management

Package



SOP-8

Circuit diagram

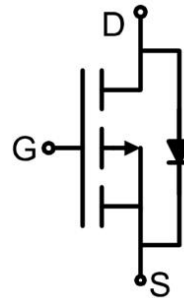

Marking



Absolute maximum ratings ($T_A=25^\circ\text{C}$ unless otherwise noted)

Parameter	Symbol	Value	Unit
Drain-Source Voltage	V_{DS}	-30	V
Gate-Source Voltage	V_{GS}	± 20	V
Continuous Drain Current	I_D	-10	A
Continuous Drain Current($T_A=100^\circ\text{C}$)	$I_D(100^\circ\text{C})$	-6.3	A
Pulsed Drain Current ¹⁾	I_{DM}	-80	A
Avalanche energy ²⁾	E_{AS}	56	mJ
Power Dissipation ³⁾	P_D	2.5	W
Thermal Resistance,Junction-to-Ambient ⁴⁾	$R_{\theta JA}$	50	$^\circ\text{C}/\text{W}$
Junction Temperature	T_J	150	$^\circ\text{C}$
Storage Temperature	T_{STG}	-55 ~ +150	$^\circ\text{C}$

Electrical characteristics ($T_J=25^\circ\text{C}$ unless otherwise noted)

Parameter	Symbol	Test Condition	Min	Typ	Max	Unit
Static Characteristics						
Drain-source breakdown voltage	$V_{(BR)DSS}$	$V_{GS}=0\text{V}, I_D=-250\mu\text{A}$	-30			V
Zero gate voltage drain current	I_{DSS}	$V_{DS}=-30\text{V}, V_{GS}=0\text{V}$			-1	μA
Gate-body leakage current	I_{GSS}	$V_{GS}=\pm 20\text{V}, V_{DS}=0\text{V}$			± 100	nA
Gate threshold voltage	$V_{GS(th)}$	$V_{DS}=V_{GS}, I_D=-250\mu\text{A}$	-1.0	-1.5	-2.5	V
Drain-source on-resistance	$R_{DS(on)}$	$V_{GS}=-10\text{V}, I_D=-10\text{A}$		14	19	m Ω
		$V_{GS}=-4.5\text{V}, I_D=-5\text{A}$		20	28	
Dynamic characteristics⁵⁾						
Input Capacitance	C_{iss}	$V_{DS}=-15\text{V}, V_{GS}=0\text{V}, f=1\text{MHz}$		1220		pF
Output Capacitance	C_{oss}			170		
Reverse Transfer Capacitance	C_{rss}			160		
Total Gate Charge	Q_g	$V_{DS}=-15\text{V}, V_{GS}=-10\text{V}, I_D=-10\text{A}$		24		nC
Gate-Source Charge	Q_{gs}			2		
Gate-Drain Charge	Q_{gd}			6		
Turn-on delay time	$t_{d(on)}$	$V_{DD}=-15\text{V}, V_{GS}=-10\text{V}, I_D=-10\text{A}, R_{GEN}=2.5\Omega$		11		nS
Turn-on rise time	t_r			4		
Turn-off delay time	$t_{d(off)}$			70		
Turn-off fall time	t_f			50		
Source-Drain Diode characteristics						
Diode Forward Current	I_S				-10	A
Diode Forward voltage	V_{SD}	$V_{GS}=0\text{V}, I_S=-10\text{A}$			-1.2	V
Reverse Recovery Time	t_{rr}	$I_F=-10\text{A}, di/dt=100\text{A}/\mu\text{s}$		35		nS
Reverse Recovery Charge	Q_{rr}			11		nC

Notes:

- 1) Repetitive rating; pulse width limited by max. junction temperature.
- 2) $T_J=25^\circ\text{C}$, $V_{DD}=-30\text{V}$, $V_G=-10\text{V}$, $R_G=25\Omega$, $L=0.5\text{mH}$, $I_{AS}=-15\text{A}$.
- 3) P_d is based on max. junction temperature, using junction-case and junction-ambient thermal resistance.
- 4) The value of $R_{\theta JA}$ is measured with the device mounted on 1 in² FR-4 board with 2oz. Copper, in the still air environment with $T_A=25^\circ\text{C}$. The maximum allowed junction temperature of 150°C . The value in any given application depends on the user's specific board design.
- 5) Guaranteed by design, not subject to production.

Typical Characteristics

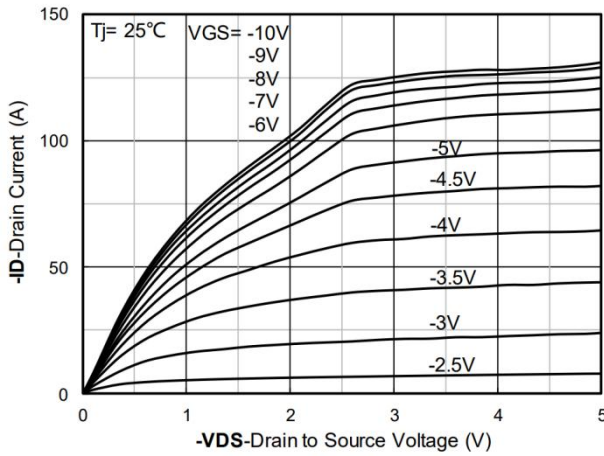

Figure 1. Output Characteristics

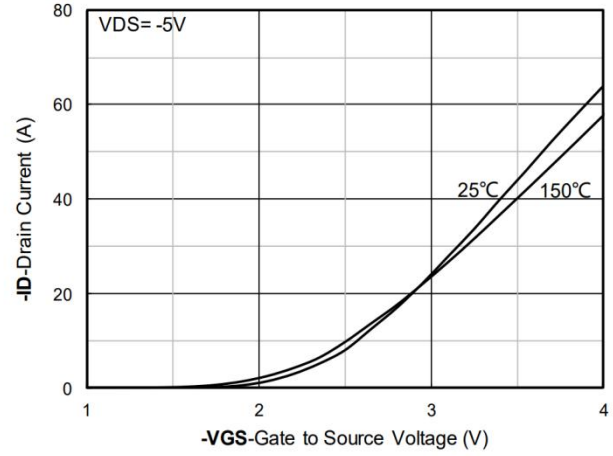

Figure 2. Transfer Characteristics

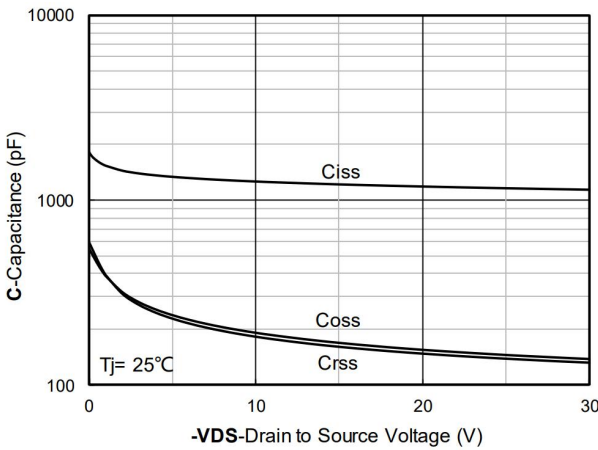

Figure 3. Capacitance Characteristics

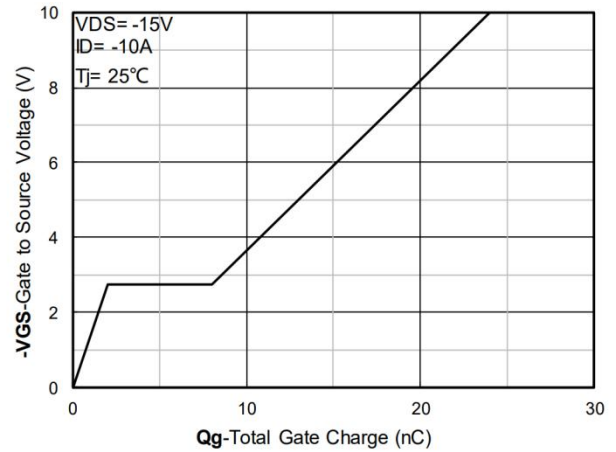

Figure 4. Gate Charge

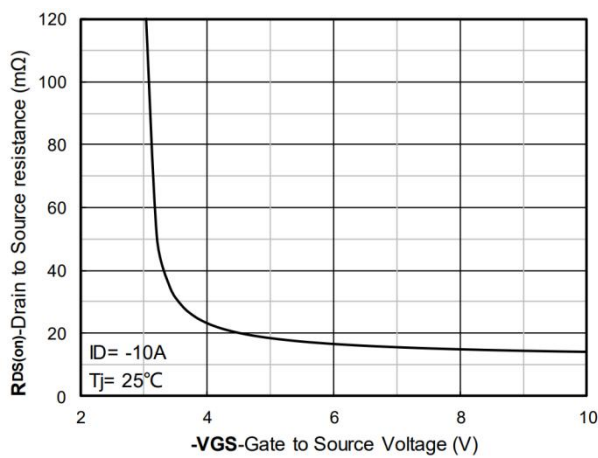

Figure 5. On-Resistance vs Gate to Source Voltage

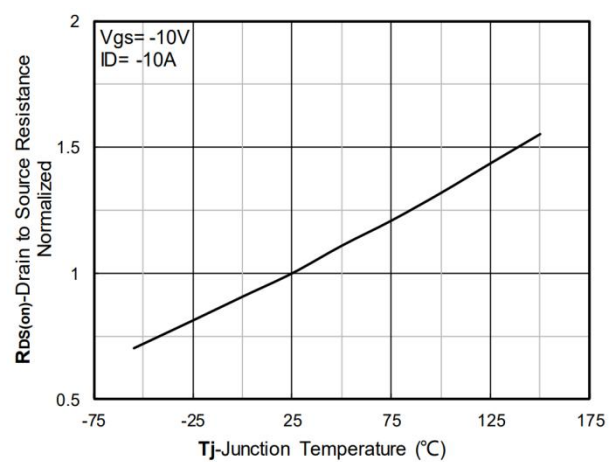

Figure 6. Normalized On-Resistance

Typical Characteristics

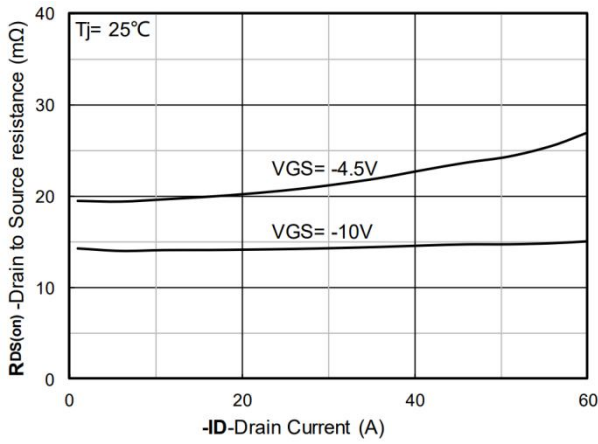

Figure 7. $R_{DS(on)}$ VS Drain Current

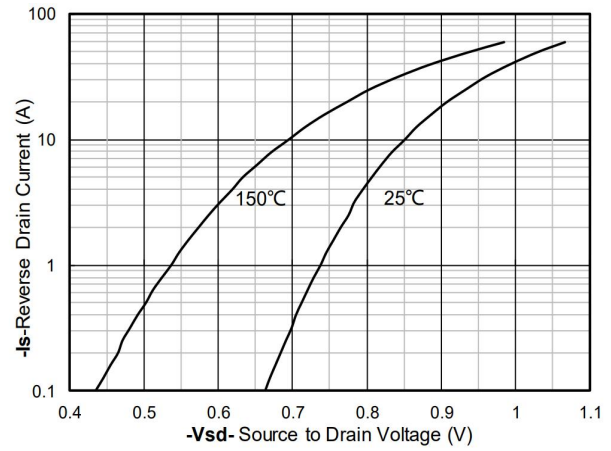

Figure 8. Forward characteristics of reverse diode

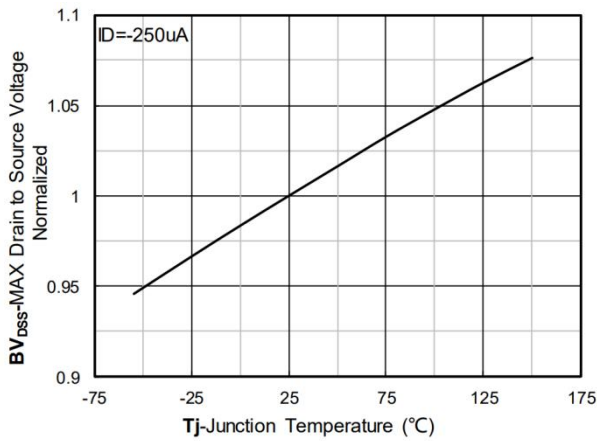

Figure 9. Normalized breakdown voltage

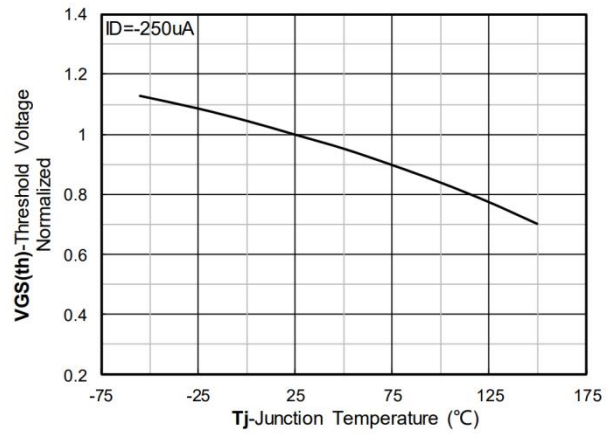

Figure 10. Normalized Threshold voltage

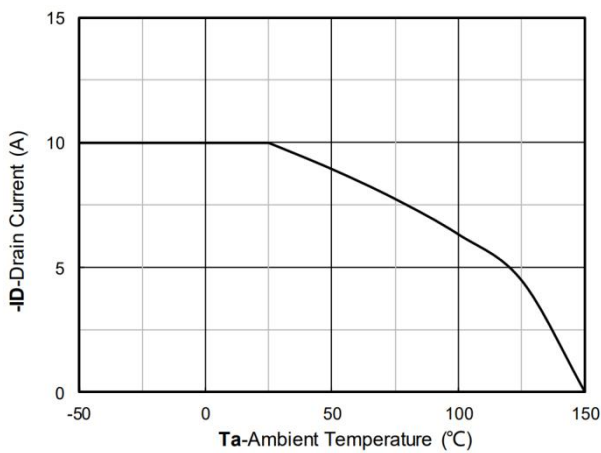

Figure 11. Current dissipation

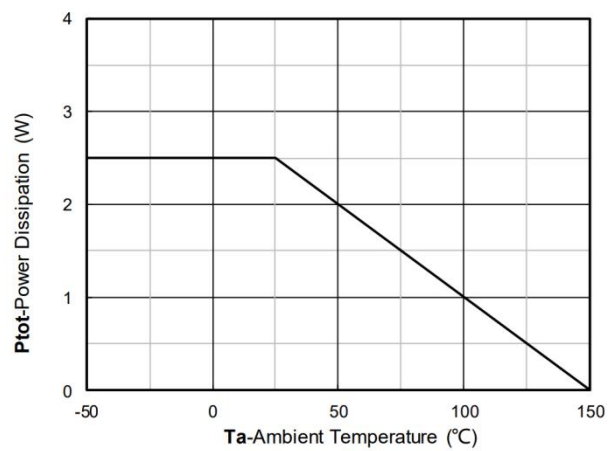

Figure 12. Power dissipation

Typical Characteristics

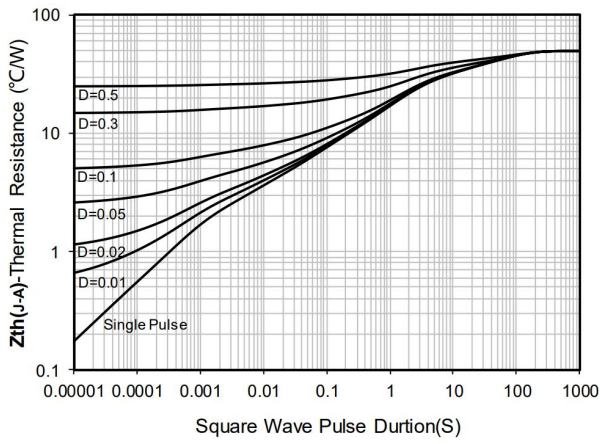

Figure 13. Maximum Transient Thermal Impedance

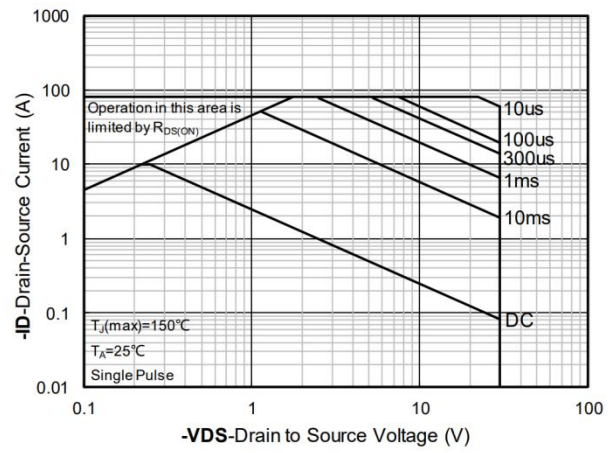
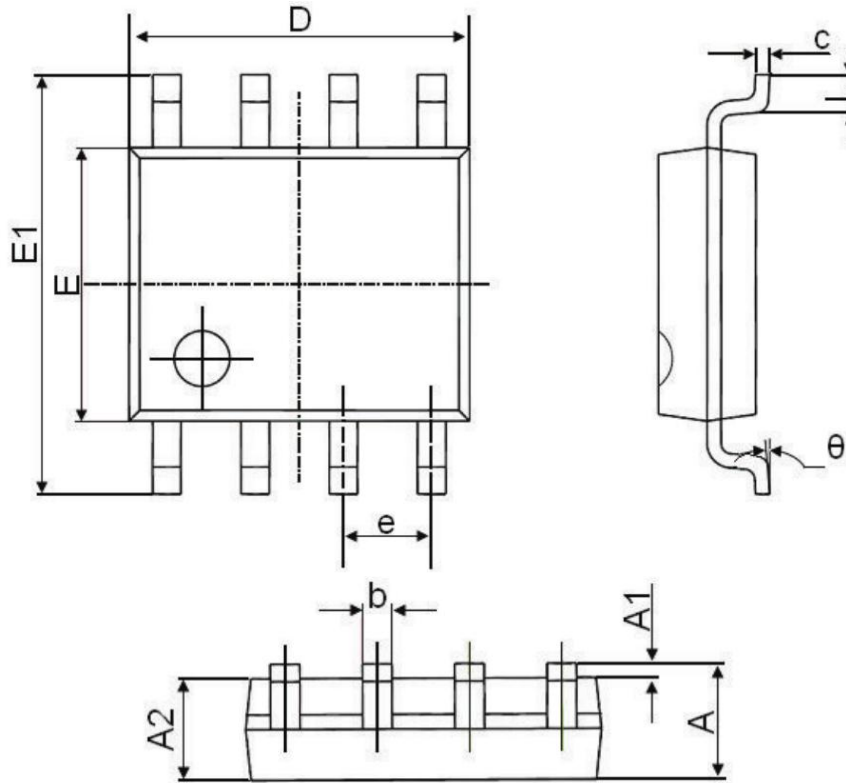

Figure 14. Safe Operation Area

SOP-8 Package Information



Symbol	Dimensions In Millimeters		Dimensions In Inches	
	Min.	Max.	Min.	Max.
A	1.350	1.750	0.053	0.069
A1	0.100	0.250	0.004	0.010
A2	1.250	1.650	0.049	0.065
b	0.330	0.510	0.013	0.020
c	0.170	0.250	0.007	0.010
D	4.700	5.100	0.185	0.200
E	3.800	4.000	0.150	0.157
E1	5.800	6.200	0.228	0.244
e	1.270(BSC)		0.050(BSC)	
L	0.400	1.270	0.016	0.050
θ	0°	8°	0°	8°