

Product Summary

$V_{(BR)DSS}$	$R_{DS(on)MAX}$	I_D
-100V	45mΩ@-10V	-35A
	55mΩ@-4.5V	

Feature

- Excellent gate charge x $R_{DS(on)}$ product(FOM)
- Very low on-resistance $R_{DS(on)}$

Application

- DC/DC converters
- Ideal for high-frequency switching and synchronous rectification

Package

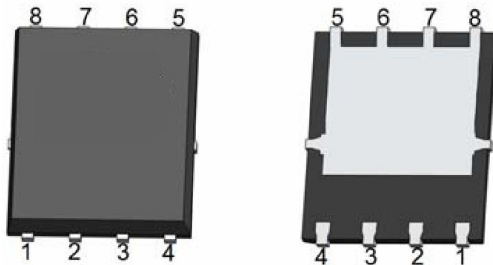

DFN5X6-8L

Circuit diagram

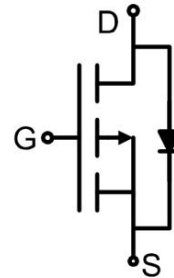

Marking

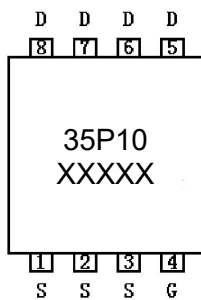

Absolute maximum ratings (T_c=25°C unless otherwise noted)

Parameter	Symbol	Value	Unit
Drain-Source Voltage	V _{DS}	-100	V
Gate-Source Voltage	V _{GS}	±20	V
Continuous Drain Current	I _D	-35	A
Continuous Drain Current (T _c =100°C)	I _D (100°C)	-24.5	A
Pulsed Drain Current	I _{DM}	-140	A
Power Dissipation	P _D	95	W
Thermal Resistance, Junction-to-Case	R _{θJC}	1.32	°C/W
Single pulse avalanche energy ¹⁾	E _{AS}	320	mJ
Junction Temperature	T _J	150	°C
Storage Temperature	T _{STG}	-55 ~ +150	°C

Electrical characteristics (T_c=25 °C unless otherwise noted)

Parameter	Symbol	Test Condition	Min.	Typ.	Max.	Unit
Static Characteristics						
Drain-source breakdown voltage	V _{(BR)DSS}	V _{GS} = 0V, I _D = -250μA	-100			V
Zero gate voltage drain current	I _{DSS}	V _{DS} = -100V, V _{GS} = 0V			-1	μA
Gate-body leakage current	I _{GSS}	V _{GS} = ±20V, V _{DS} = 0V			±100	nA
Gate threshold voltage	V _{GS(th)}	V _{DS} = V _{GS} , I _D = -250μA	-1	-1.7	-2.5	V
Drain-source on-resistance	R _{DS(on)}	V _{GS} = -10V, I _D = -20A		37	45	mΩ
		V _{GS} = -4.5V, I _D = -20A		45	55	
Dynamic characteristics²⁾						
Input Capacitance	C _{iss}	V _{DS} = -50V, V _{GS} = 0V, f = 1MHz		3445		pF
Output Capacitance	C _{oss}			260		
Reverse Transfer Capacitance	C _{rss}			14		
Total Gate Charge	Q _g	V _{DS} = -50V, V _{GS} = -10V, I _D = -20A		46		nC
Gate-Source Charge	Q _{gs}			10.5		
Gate-Drain Charge	Q _{gd}			4.5		
Turn-on delay time	t _{d(on)}	V _{DD} = -50V, V _{GS} = -10V, R _G = 1.6Ω, I _D = -20A		12.5		nS
Turn-on rise time	t _r			10		
Turn-off delay time	t _{d(off)}			45		
Turn-off fall time	t _f			12		
Source-Drain Diode characteristics						
Diode Forward Current	I _S				-35	A
Diode Forward voltage	V _{SD}	V _{GS} = 0V, I _S = -20A			-1.2	V
Reverse Recovery Time	t _{rr}	T _J = 25°C, I _F = -20A		50		nS
Reverse Recovery Charge	Q _{rr}	di/dt = 100A/μs		90		nC

Notes:

- 1) EAS condition : T_J = 25°C, V_{DD} = -50V, V_G = -10V, L = 0.5mH, R_G = 25Ω.
- 2) Guaranteed by design, not subject to production.

Typical Characteristics

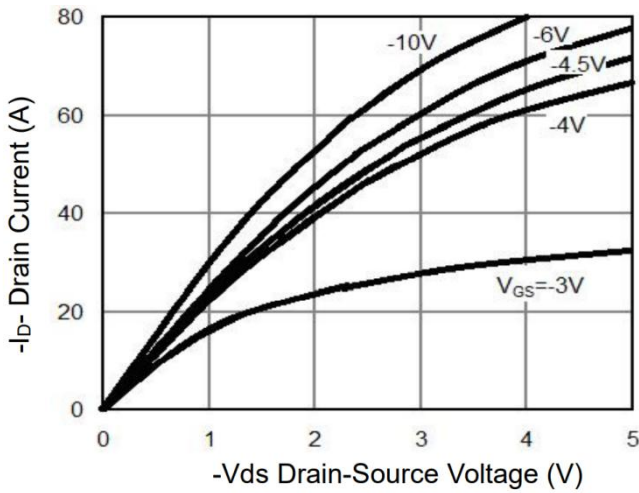

Figure 1 Output Characteristics

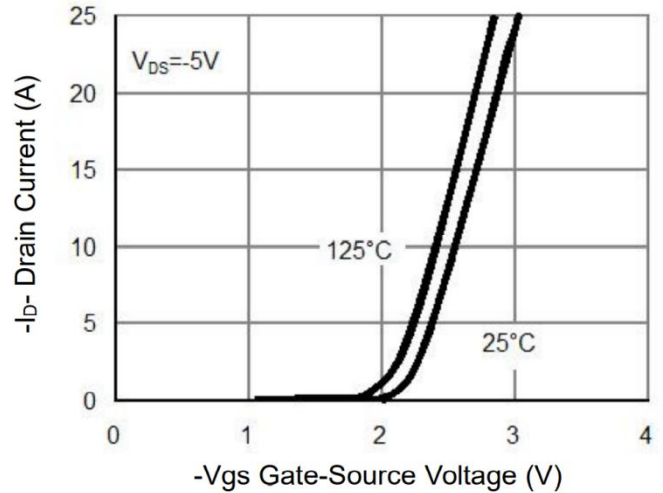

Figure 2 Transfer Characteristics

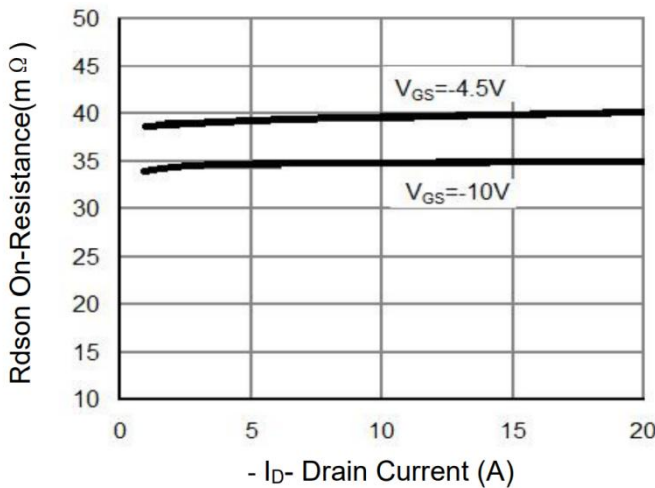

Figure 3 Rdson- Drain Current

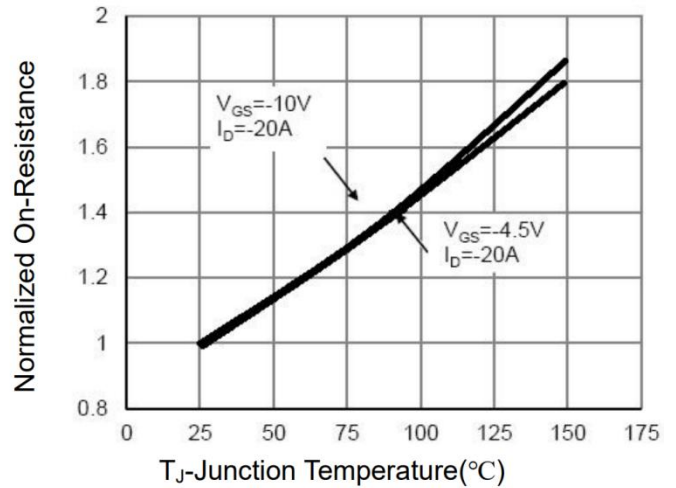

Figure 4 Rdson-Junction Temperature

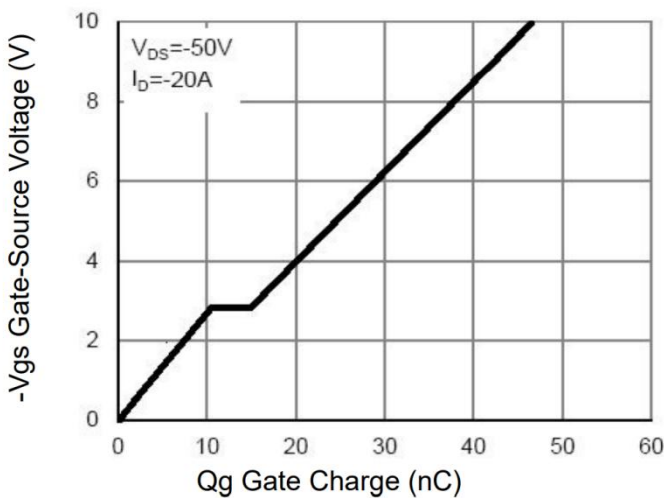

Figure 5 Gate Charge

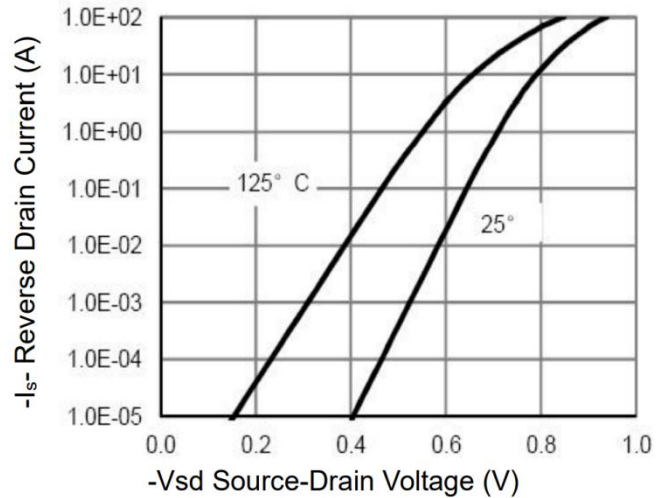

Figure 6 Source- Drain Diode Forward

Typical Characteristics

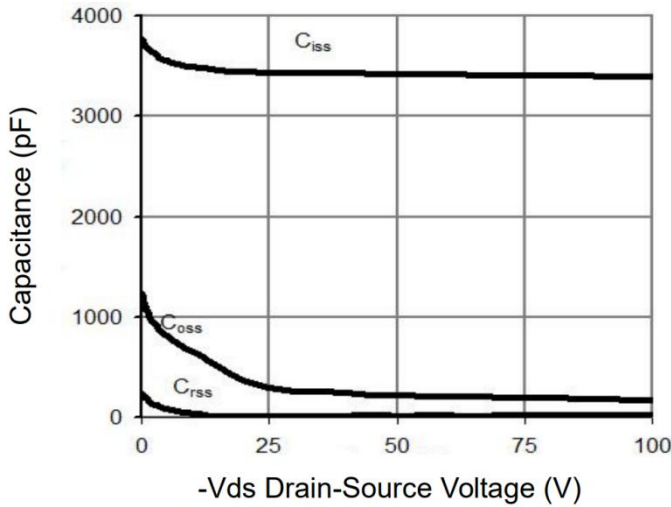

Figure 7 Capacitance vs Vds

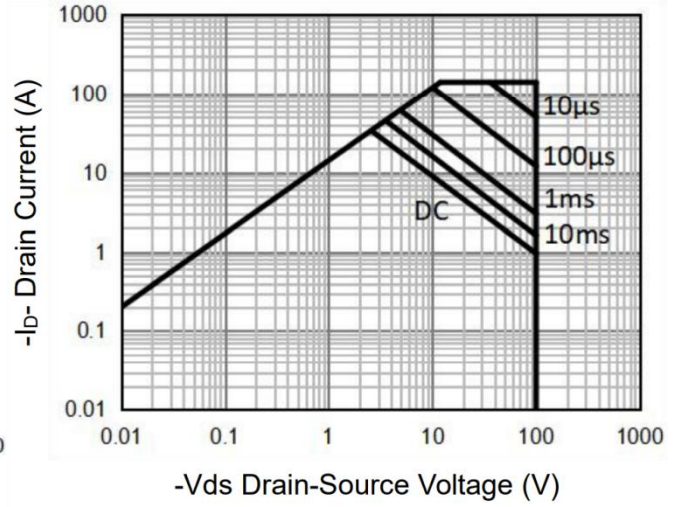

Figure 8 Safe Operation Area

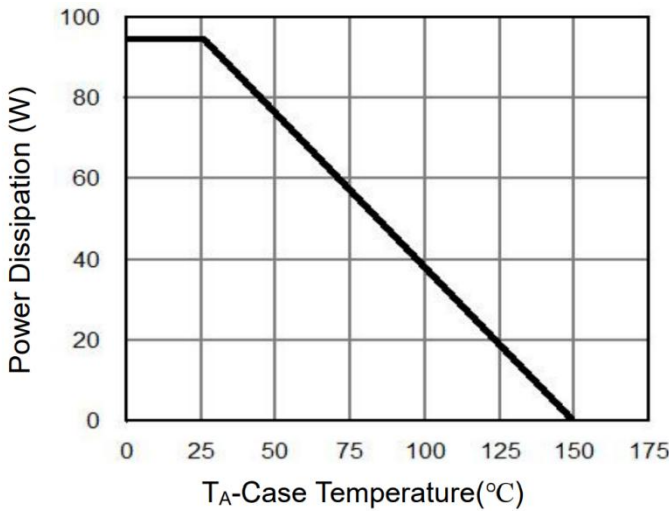

Figure 9 Power De-rating

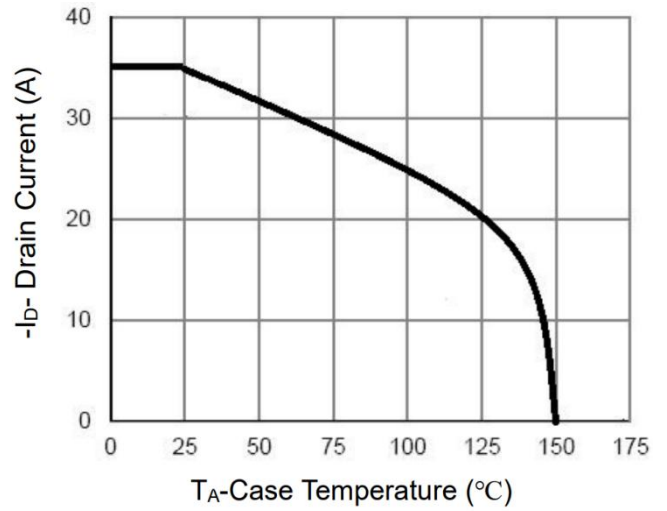

Figure 10 Current De-rating

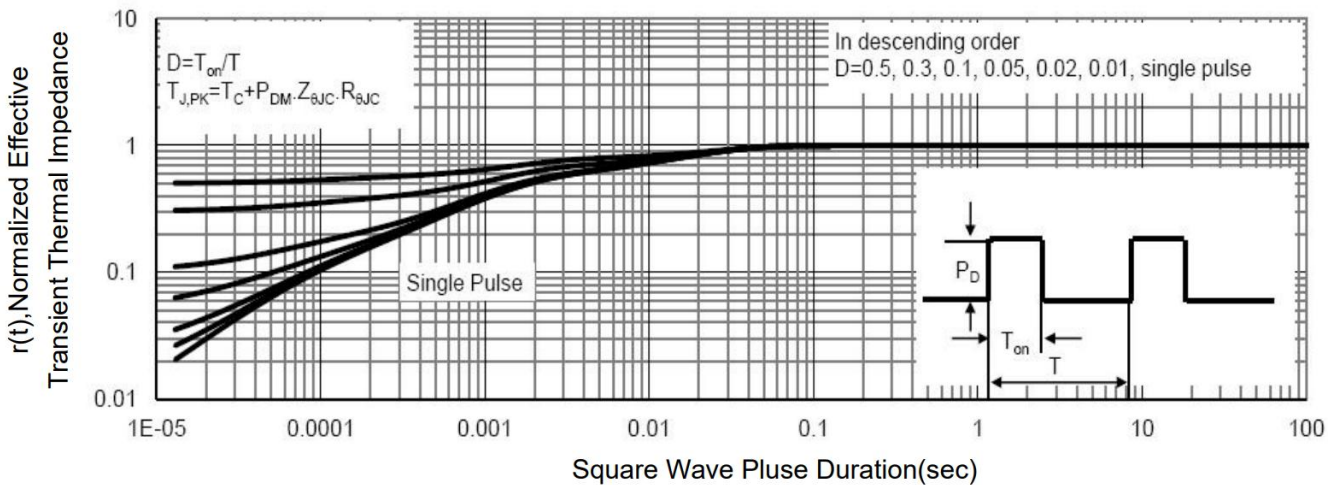
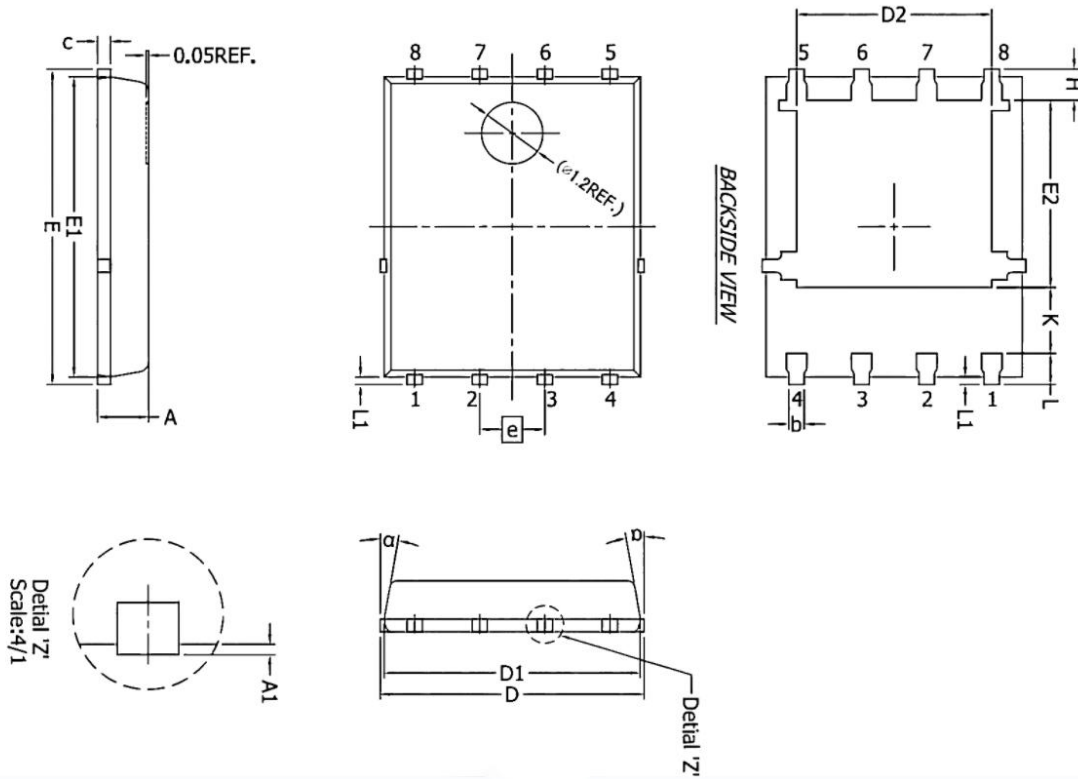

Figure 11 Normalized Maximum Transient Thermal Impedance

DFN5X6-8L Package Information



Symbol	Dimensions In Millimeters		Dimensions In Inches	
	Min.	Max.	Min.	Max.
A	0.900	1.100	0.035	0.043
A1	-	0.050	-	0.002
b	0.300	0.500	0.012	0.020
c	0.200	0.300	0.008	0.012
D	5.15 BSC		0.203 BSC	
D1	5.00 BSC		0.197 BSC	
D2	3.760	3.860	0.148	0.152
E	6.150 BSC		0.242 BSC	
E1	5.800	5.900	0.228	0.232
E2	3.450	3.850	0.136	0.152
e	1.270 BSC		0.050 BSC	
H	0.510	0.710	0.020	0.028
K	1.100	-	0.043	-
L	0.510	0.710	0.020	0.028
L1	0.080	0.230	0.003	0.009
α	10°	12°	10°	12°