

Product Summary

$V_{(BR)DSS}$	$R_{DS(on)MAX}$	I_D
-55V	40mΩ@-10V	-30A

Feature

- High density cell design for ultra low Rdson
- Fully characterized avalanche voltage and current
- Good stability and uniformity with high E_{AS}
- Excellent package for good heat dissipation

Application

- Power switching application
- Hard switched and high frequency circuits
- Uninterruptible power supply

Package

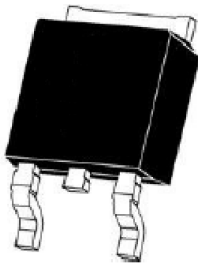

TO-252AB

Circuit diagram

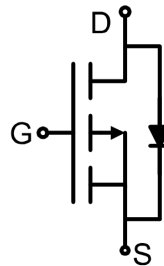

Marking

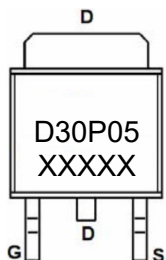

Absolute maximum ratings (Ta=25°C unless otherwise noted)

Parameter	Symbol	Value	Unit
Drain-Source Voltage	V_{DS}	-55	V
Gate-Source Voltage	V_{GS}	±20	V
Continuous Drain Current	I_D	-30	A
Pulsed Drain Current	I_{DM}	-110	A
Power Dissipation	P_D	65	W
Thermal Resistance, Junction-to-Case	$R_{\theta JC}$	2.3	°C/W
Single pulse avalanche energy	E_{AS}	420	mJ
Junction Temperature	T_J	150	°C
Storage Temperature	T_{STG}	-55 ~ +150	°C

Electrical characteristics (T_A=25 °C, unless otherwise noted)

Parameter	Symbol	Test Condition	Min.	Typ.	Max.	Unit
Static Characteristics						
Drain-source breakdown voltage	$V_{(BR)DSS}$	$V_{GS} = 0V, I_D = -250\mu A$	-55			V
Zero gate voltage drain current	I_{DSS}	$V_{DS} = -55V, V_{GS} = 0V$			-1	μA
Gate-body leakage current	I_{GSS}	$V_{GS} = \pm 20V, V_{DS} = 0V$			±100	nA
Gate threshold voltage	$V_{GS(th)}$	$V_{DS} = V_{GS}, I_D = -250\mu A$	-2		-4	V
Drain-source on-resistance ¹⁾	$R_{DS(on)}$	$V_{GS} = -10V, I_D = -15A$		30	40	mΩ
Forward transconductance ¹⁾	g_{FS}	$V_{DS} = -25V, I_D = -16A$	8			S
Dynamic characteristics²⁾						
Input Capacitance	C_{iss}	$V_{DS} = -30V, V_{GS} = 0V, f = 1MHz$		3500		pF
Output Capacitance	C_{oss}			240		
Reverse Transfer Capacitance	C_{rss}			153		
Total Gate Charge	Q_g	$V_{DS} = -30V, V_{GS} = -10V, I_D = -15A$		56		nC
Gate-Source Charge	Q_{gs}			11		
Gate-Drain Charge	Q_{gd}			24		
Turn-on delay time	$t_{d(on)}$	$V_{DD} = -30V, V_{GS} = -10V, I_D = -15A, R_{GEN} = 3\Omega$		12		nS
Turn-on rise time	t_r			15		
Turn-off delay time	$t_{d(off)}$			38		
Turn-off fall time	t_f			15		
Source-Drain Diode characteristics						
Diode Forward Current ¹⁾	I_S				-30	A
Diode Forward voltage	V_{DS}	$V_{GS} = 0V, I_S = -15A$			-1.2	V
Reverse Recovery Time	t_{rr}	$T_J = 25^\circ C, I_F = -15A$			71	nS
Reverse Recovery Charge	Q_{rr}	$di/dt = 100A/\mu s$ ¹⁾			170	nC

Notes:

- 1) Pulse Test: Pulse Width < 300μs, Duty Cycle ≤ 2%.
- 2) Guaranteed by design, not subject to production testing.

Test Circuit

1) E_{AS} test Circuit

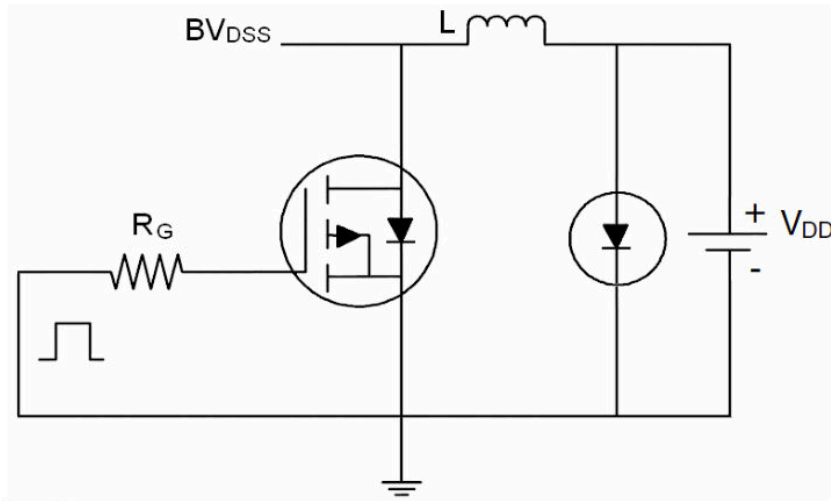

2) Gate charge test Circuit

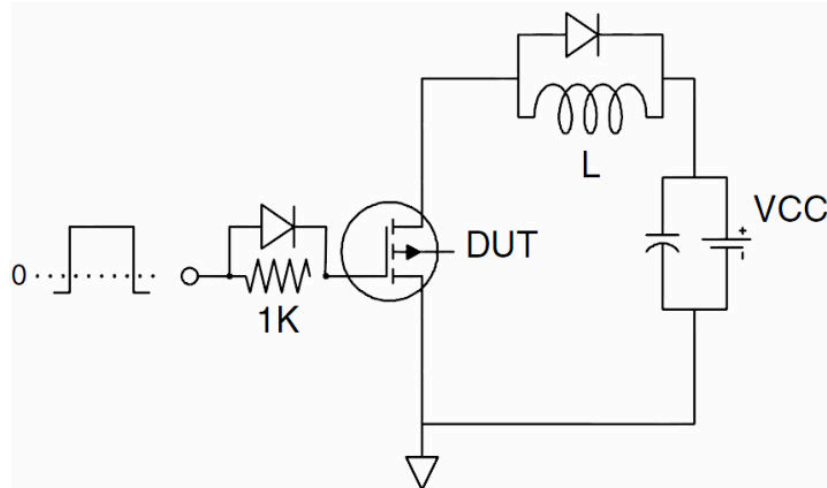

3) Switch Time Test Circuit

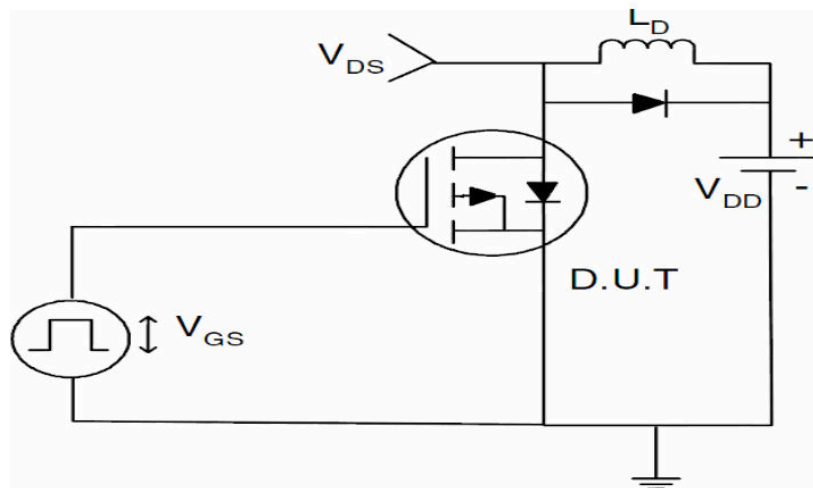

Typical Characteristics

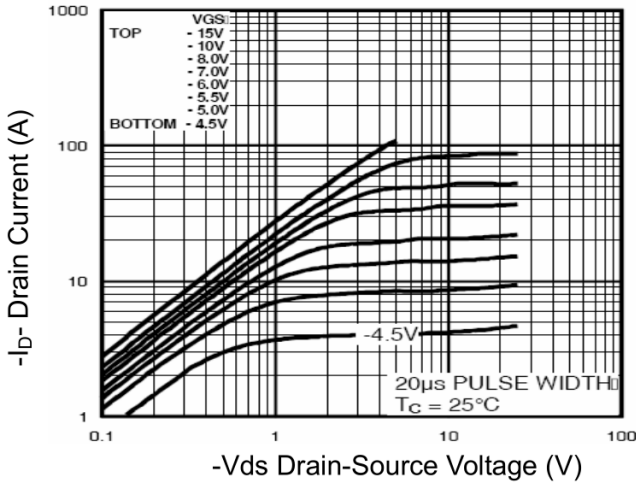

Figure 1 Output Characteristics

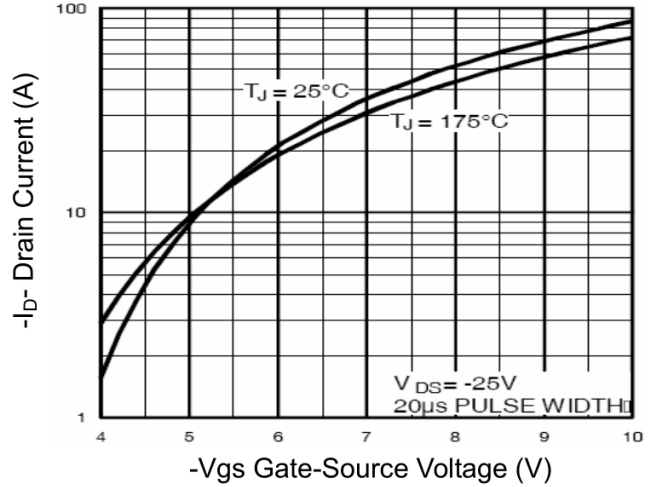

Figure 2 Transfer Characteristics

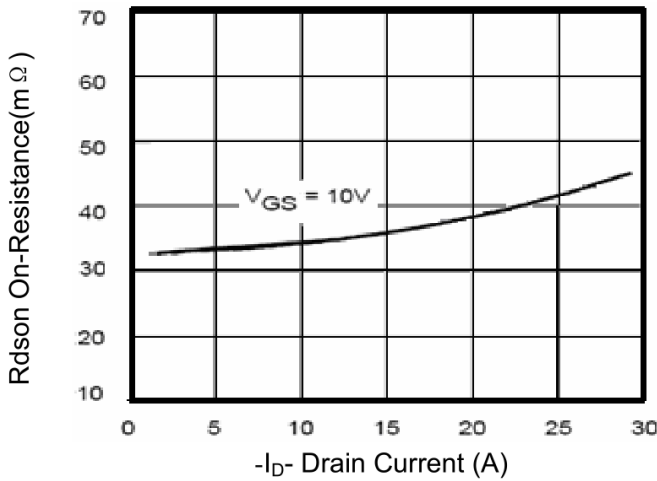

Figure 3 Rdson- Drain Current

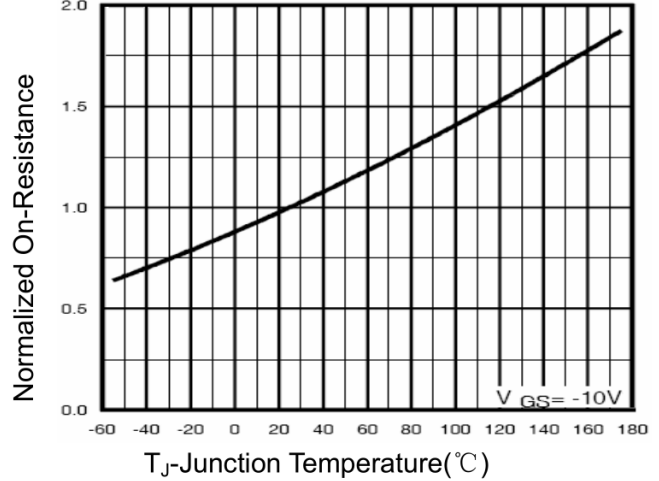

Figure 4 Rdson-Junction Temperature

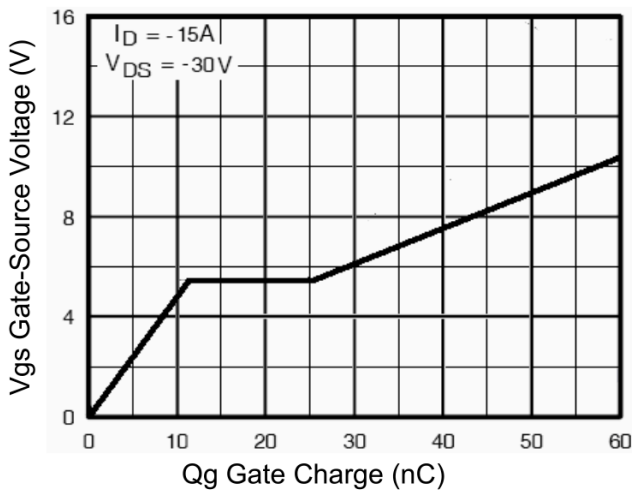

Figure 5 Gate Charge

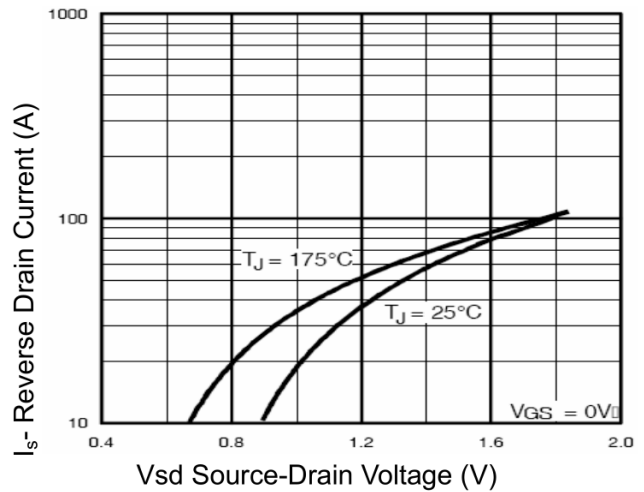

Figure 6 Source- Drain Diode Forward

Typical Characteristics

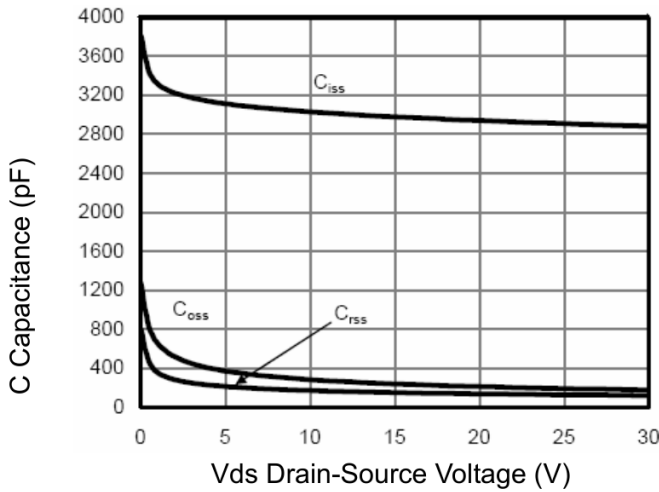

Figure 7 Capacitance vs Vds

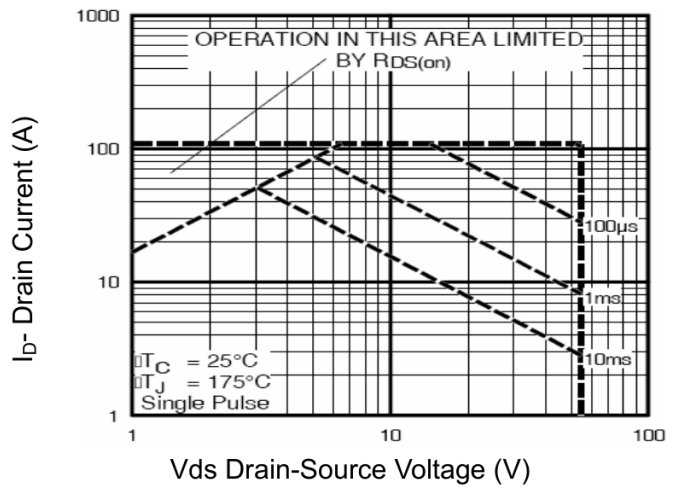

Figure 8 Safe Operation Area

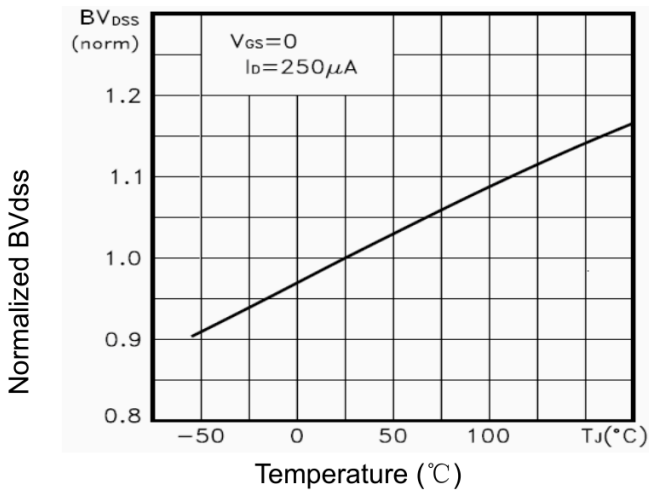

Figure 9 BV_{DSS} vs Junction Temperature

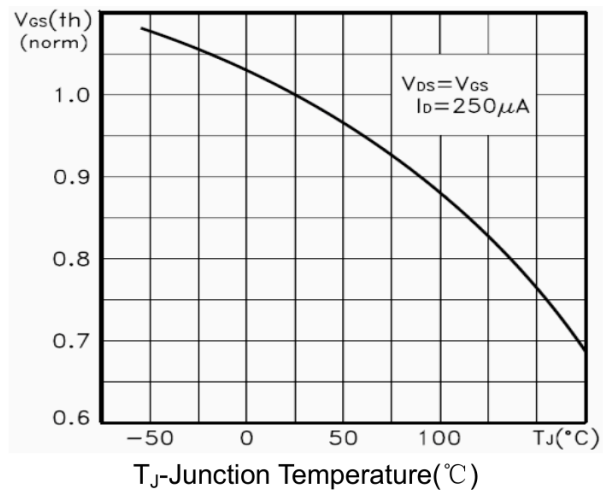

Figure 10 V_{GS(th)} vs Junction Temperature

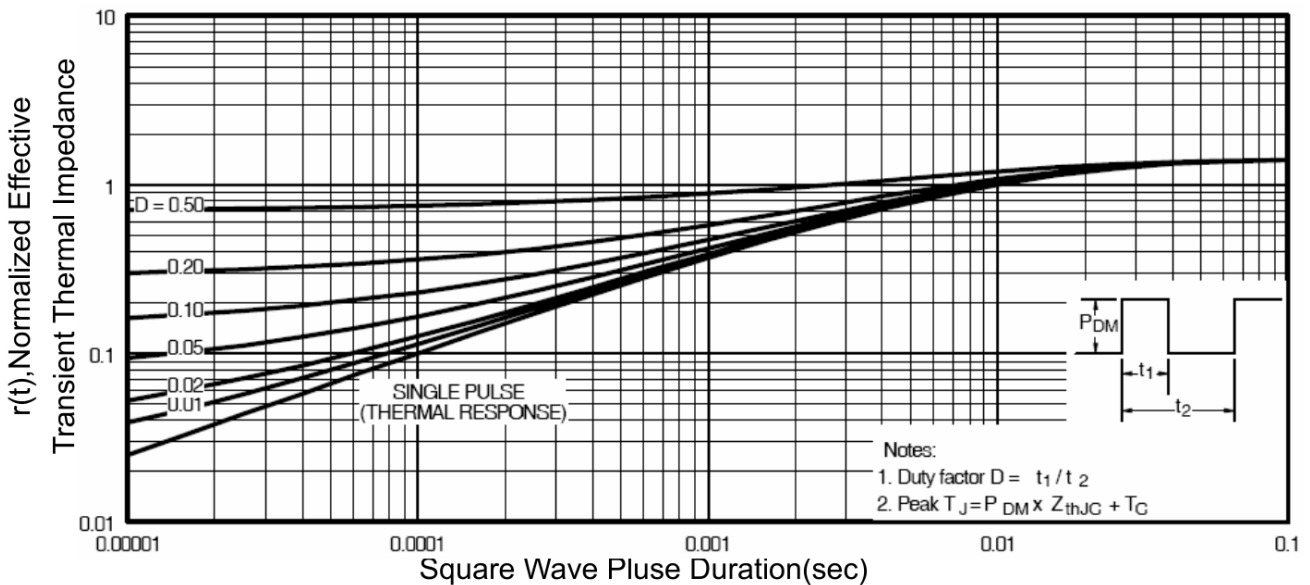
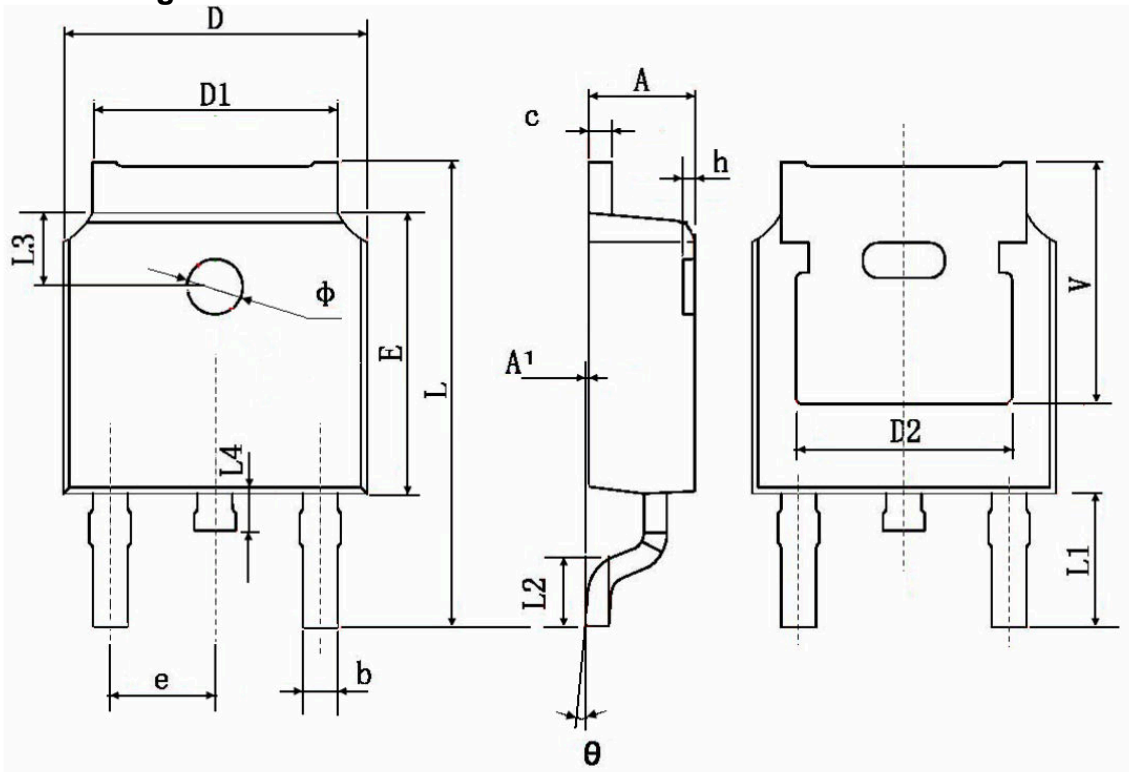

Figure 11 Normalized Maximum Transient Thermal Impedance

TO-252AB Package Information



Symbol	Dimensions In Millimeters		Dimensions In Inches	
	Min.	Max.	Min.	Max.
A	2.200	2.400	0.087	0.094
A1	0.000	0.127	0.000	0.005
b	0.660	0.860	0.026	0.034
c	0.460	0.580	0.018	0.023
D	6.500	6.700	0.256	0.264
D1	5.100	5.460	0.201	0.215
D2	4.830 TYP.		0.190 TYP.	
E	6.000	6.200	0.236	0.244
e	2.186	2.386	0.086	0.094
L	9.800	10.400	0.386	0.409
L1	2.900 TYP.		0.114 TYP.	
L2	1.400	1.700	0.055	0.067
L3	1.600 TYP.		0.063 TYP.	
L4	0.600	1.000	0.024	0.039
Φ	1.100	1.300	0.043	0.051
θ	0°	8°	0°	8°
h	0.000	0.300	0.000	0.012
V	5.350 TYP.		0.211 TYP.	